



MUTHAYAMMAL ENGINEERING COLLEGE

(An Autonomous Institution)

(Approved by AICTE, New Delhi, Accredited by NAAC & Affiliated to
Anna University)

Rasipuram - 637 408, Namakkal Dist., Tamil Nadu



BME

QUESTION BANK

19BMC06 & BIO CONTROL SYSTEM

UNIT I

CONTROL SYSTEM MODELING

PART A

1. Formulate the force balance equation for ideal dash pot and ideal spring.
2. Create the expression for Mason's gain formula to find the system transfer function.
3. Can we use servomotor for position control? Support the answer with necessary details.
4. Give the aligned position of a Synchro transmitter and synchro receiver.
5. Define open loop and closed loop system.
6. Compare Signal Flow Graph approach with block diagram reduction technique of determining transfer function.
7. State the terms Path and Forward Path.
8. Mention the Block Diagram Reduction techniques.
9. Describe the characteristics of negative feedback in control systems.
10. Write short notes on Synchros.
11. Why negative feedback is preferred in closed loop control system.
12. List the basic elements for modeling in mechanical rotational system.
13. Define transfer function. Give an example for it.
14. What are the basic elements in control systems?
15. What is feedback?
16. Mention the classification of control system.
17. For what purpose Laplace transform is used in control system?
18. Enumerate the advantages of transfer function.
19. Give the important features of feedback.
20. Write any two rules in block diagram reduction technique.

PART – B

- Determine the transfer function $Y_2(s)/F(s)$ of the system shown in figure.

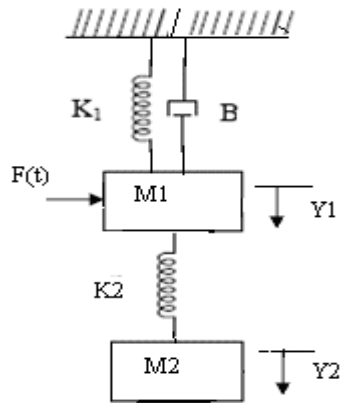

- Determine the transfer function of the mechanical system shown in figure. Also draw its F-V analogy circuit and F-I analogy circuit.

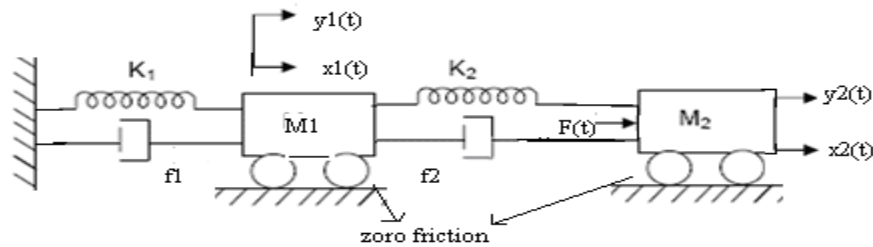

- Draw the voltage and current analogs for the following mechanical system.

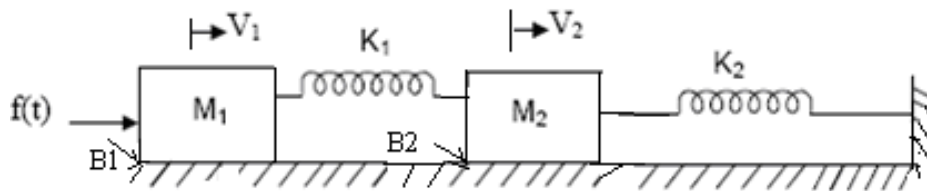

- Draw the electrical equivalent network for the mechanical system shown in figure, using force to voltage analogy. Also, determine its transfer function.

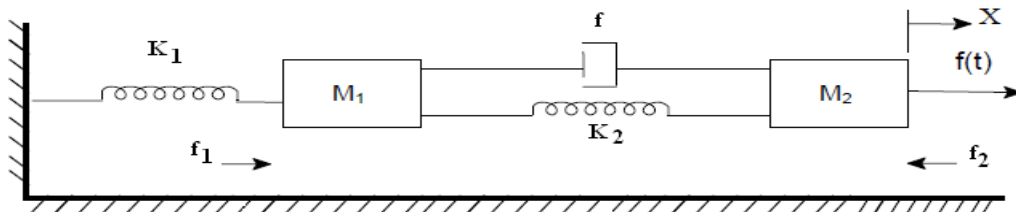

5. Find the overall gain of the system whose signal flow graph is shown in figure.

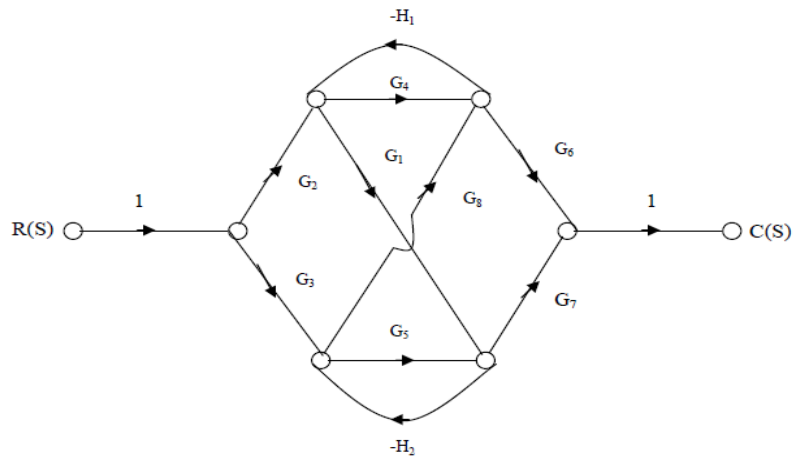

6. Write the differential equations governing the mechanical system shown in fig. draw the T-V and T-I electrical analogous circuits.

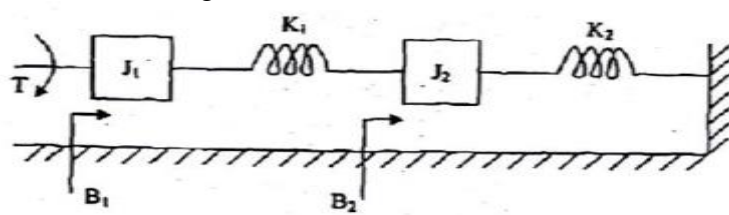

7. Reduce the block diagram and obtain $C(s) / R(s)$.

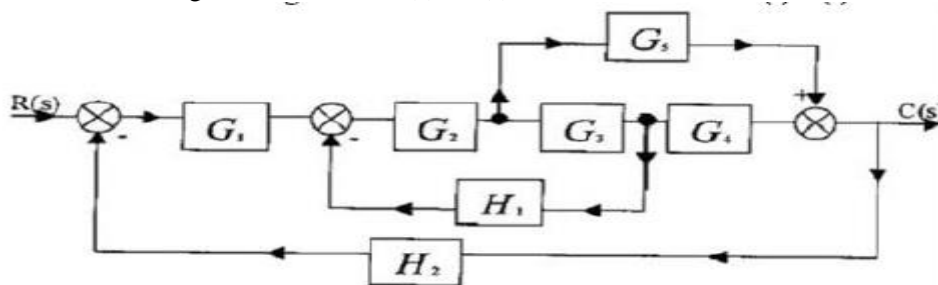

8. Determine the overall transfer function $C(s) / R(s)$ for the system.

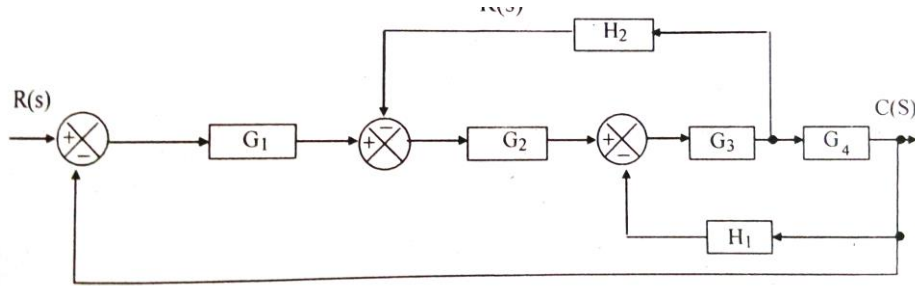

9. Find the overall gain $C(s) / R(s)$ for the signal flow graph shown in figure.

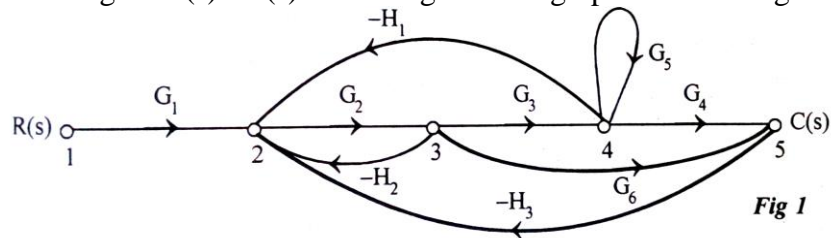

10. Derive the equations of transfer function of Armature controlled DC motor.

UNIT II TIME RESPONSE ANALYSIS

PART-A

1. Infer why derivative controller is not separately used in control systems.
2. Write down the relation between static and dynamic error coefficients.
3. Give the type and order of the following system $G(S)H(S)=200/S^2+20S+200$
4. What is steady state error? Mention the 3-different static error constants.
5. What is meant by time response?
6. Distinguish between type and order of the system.
7. State the settling time.
8. Define peak overshoot.
9. Write short notes on transient response & steady state response?
10. What are the standard test signals and for what purpose standard test signals are used?
11. Draw the transfer function model for PID control.
12. Sketch the response of a second order under damped system?
13. Mention the effect of PI controller on the system performance.
14. Estimate the damped frequency of oscillation for a second order system which has a damping ratio of 0.6 and natural frequency of oscillation is 10 rad/sec.
15. Interpret the type and order of the system $G(S)H(S)=(S+4)/(S-2)(S+0.25)$
16. Infer why derivative controller is not separately used in control systems.
17. For the system described by Show the nature of the time response $C(s)/R(S)=16/(S^2+8S+16)$.
18. Distinguish between type and order of a system.
19. List the time domain specifications.

20. The damping ratio of a system is 0.75 and the natural frequency of oscillation is 12 rad/sec. Determine the peak overshoot and the peak time.

PART – B

1. (i) A unity feedback system is characterized by the open-loop transfer function $G(s) = 1 / (s(0.5s+1)(0.2s+1))$. Determine static error constants and the steady state errors for unit-step, unit-ramp and unit-acceleration inputs.
 (ii) The open loop transfer function of a servo system with unity feedback is $G(s) = 10 / s(0.1s+1)$. Evaluate the static error constants of the system. Obtain the steady state error of the system, when subjected to an input given by the polynomial, $r(t) = a_0 + a_1t + (a_2/2)t^2$.
2. Measurements conducted on a Servomechanism show the system response to be $c(t) = 1 + 0.2e^{-60t} - 1.2e^{-10t}$ when subjected to a unit step. Obtain an expression for closed loop transfer function and also calculate rise time, peak time, Maximum overshoot and settling time.
3. A unity feedback control system has an open loop transfer function $G(s) = k / (s(s+10))$. Determine the gain k so that the system will have a damping ratio of 0.5 for this value of k . Find the rise time, percentage overshoot, peak time and settling time for a step input.
4. Discuss the functioning P, I and D controllers with necessary diagrams and state how they are used to meet the specifications for the given system.
5. A unity feedback control system has the forward path transfer function

$$G(S) = \frac{K}{S + 9}$$

Choose the value of K such that the closed loop system has a damping ratio of 0.5. For this value of K , find the steady state error of the closed loop system when it is subjected by an input given by $r(t) = 1.5 + 2t + 0.5t^2$.

6. (i) Measurements conducted on a Servomechanism show the system response to be $c(t) = 1 + 0.2e^{-60t} - 1.2e^{-10t}$ when subjected to a unit step. Give the expression for closed loop transfer function.
 (ii) What is the response $c(t)$ to the unit step input. Given that $\zeta = 0.5$ and also calculate rise time, peak time, Maximum overshoot and settling time.

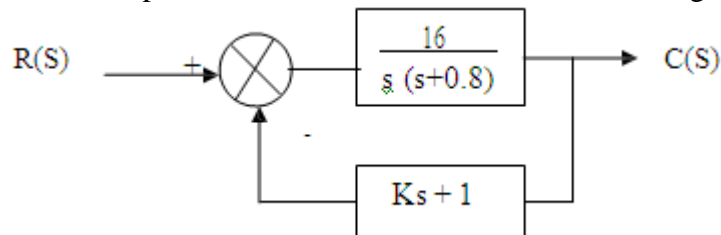

7. With a step input of 12 units, for a unity feedback control system which has an open loop transfer function $G(S) = 10 / S(S+2)$. Find (i) Rise time
 (ii) Percentage overshoot
 (iii) Peak time
 (iv) Settling time
8. (i) Find the static error constants for a unity feedback system having a forward path transfer function $G(S) = 50 / S(S+10)$

- (ii) For the above transfer function, interpret the steady state errors of the system for the input $r(t) = 1 + 2t + t^2$
9. A unity feedback system is characterized by the open-loop transfer function $G(s) = 1 / (s(0.5s+1)(0.2s+1))$. Determine the steady state errors for unit-step, unit-ramp and unit-acceleration inputs and Determine rise time, peak time, peak Overshoot and settling time of the unit- step response of the system.
 10. For a unity feedback control system, the open loop transfer function is $G(S)=10(S+2)/S^2+(S+1)$

Construct the (i) The position, velocity, acceleration error constants

(ii) The steady state error when

$$R(s) = \left(\frac{3}{s}\right) - \left(\frac{2}{s^2}\right) + \left(\frac{1}{3s^3}\right)$$

UNIT -III FREQUENCY RESPONSE ANALYSIS

PART A

1. State cut-off rate & resonant peak(Mr).
2. Define bandwidth.
3. Draw the polar plot for the transfer function $G(S)=1/(1+TS)$.
4. Illustrate the circuit of lead compensator and draw its pole zero diagram.
5. What is meant by frequency response of system? What are frequency domain specifications?
6. List the frequency domain methods to find the stability of the system.
7. Give the advantages of frequency response analysis?
8. What is a polar plot? Give the advantages of polar plots?
9. Formulate the transfer function of a lead compensator network.
10. What is Nichol's chart?
11. How the closed loop frequency response is determined from the open loop frequency response?
12. Define gain-cross over frequency (ω_{gc}) & phase-cross over frequency (ω_{pc}).
13. Shortly discuss about the term gain margin & phase margin.
14. Write short notes on M and N circles?
15. What happens to the damping ratio and rise time if the band width is increased?
16. For a stable system the gain margin and phase margin should be positive. Justify your answer.
17. Analyze the effects of addition of poles and zeros in polar plot.
18. Draw the approximate polar plot for a Type 0 second order system.
19. Illustrate the need for compensation.
20. State the significance of Nichol's plot.

PART-B

1. Sketch the polar plot for the following transfer function and find Gain cross over frequency, Phase cross over frequency, Gain margin and Phase margin. $G(S) = 400 / S(S+2)(S+10)$
2. Describe the design procedure of lag- Lead compensator using Bode -plot.
3. Sketch the Bode plot and hence find Gain cross over frequency, Phase cross over frequency, Gain margin and Phase margin. $G(S) = 10(1+0.1S) / S(1+0.01S)(1+S)$.
4. Write the short notes on correlation between the time and frequency response?
5. Given $G(s) = Ke^{-0.2s} / s(s+2)(s+8)$. Draw the Bode plot and find K for the following two cases: Gain margin equal to 6dB and Phase margin equal to 45° .
6. Plot the Bode diagram for the following transfer function and obtain the gain and phase cross over frequencies. $G(S) = 10 / S(1+0.4S)(1+0.1S)$
7. The open loop transfer function of a unity feedback system is $G(S) = 1 / S(1+S)(1+2S)$ Sketch the Polar plot and determine the Gain margin and Phase margin.
8. Sketch the Bode plot and hence find Gain cross over frequency, Phase cross over frequency, Gain margin and Phase margin $G(S) = 0.75(1+0.2S) / S(1+0.5S)(1+0.1S)$
9. Draw the polar plot for the open loop transfer function with unity feedback system given by $G(S) = 1 / s^2(1+s)(1+2s)$.
10. Determine the phase margin and gain margin. Plot the Bode diagram for the following transfer function and obtain the gain and phase cross over frequencies. $G(S) = KS^2 / (1+0.2S)(1+0.02S)$. Determine the value of K for a gain cross over frequency of 20 rad/sec.

UNIT IV **STABILITY ANALYSIS**

PART A

1. Identify any two limitations of Routh-stability criterion.
2. Point out the advantages of Nyquist stability criterion over that of Routh's criterion.
3. What is meant by system stability?
4. State Nyquist stability criterion.
5. List the advantages of Routh Hurwitz stability criterion.
6. What is the advantage of using root locus for design?
7. Express the rules to obtain the breakaway point in root locus
8. Describe BIBO stability Criterion
9. Define Centroid.
10. Write about Root locus Method.
11. Illustrate the necessary and sufficient condition for stability.
12. Name the effects of addition of open loop poles.
13. Elaborate the Parameters which constitute frequency domain Specifications.
14. Define characteristic equation.
15. In routh array what conclusion you can make when there is a row of all zeros.

16. Relate roots of characteristic equation to stability.
17. Examine dominant pole.
18. Compare the regions of root locations for stable, unstable and limitedly stable systems.
19. Mention asymptotes. How will you find the angle of asymptotes?
20. Using Routh Criterion, design the stability of the system represented by the characteristic equation $s^4+8s^3+18s^2+16s+5=0$.

PART B

1. (i) Express the mathematical preliminaries for Nyquist stability criterion
(ii) Explain the procedure for Nyquist Stability Criterion.
2. (i) Examine the open loop gain for a specified damping of the dominant roots.
(ii) Point out the concepts BIBO stability.
3. (i) Write detailed notes on relative stability with its roots of S- plane.
(ii) State and explain about different cases of Routh Hurwitz criterion.
4. Construct the root locus and determine the stability of the system whose characteristic equation is $s^6+2s^5+8s^4+12s^3+20s^2+16s+16=0$. Also determine the number of roots lying on right half of s-plane, left half of s-plane and on imaginary axis.
5. By Routh stability criterion determine the stability of the system represented by the characteristic equation $9s^5-20s^4+10s^3-s^2-9s-10=0$. Comment on the location of roots of characteristic equation.
6. Draw the Nyquist plot for the system whose open loop transfer function is,

$$G(s)H(s) = \frac{K}{s(s+2)(s+10)} . \text{ Determine the range of K for which closed loop system is stable.}$$

7. Construct the Nyquist plot for a system whose open loop transfer function is given by,

$$G(s)H(s) = \frac{K(1+s)(1+s)}{s^3} . \text{ Find the range of K for stability.}$$

8. A unity feedback control system has an open loop transfer function,

$$G(s) = \frac{K}{s(s^2+4s+13)} . \text{ Sketch the root locus.}$$

9. Sketch the root locus whose open loop transfer function is,

$$G(s) = \frac{K}{s(s+2)(s+4)} . \text{ Find the value of K so that the closed loop system is 0.5.}$$

10. Sketch the root locus for the unity feedback system whose open loop transfer function is,

$$G(s)H(s) = \frac{K(s+1.5)}{s(s+1)(s+5)}$$

UNIT V
STATE VARIABLE ANALYSIS AND BIOMEDICAL APPLICATIONS
PART A

1. Name the methods of state space representation for phase variables.
2. What is meant by quantization?
3. Write the properties of State transition matrix?
4. Determine the controllability of the system described by the state equation.
5. Evaluate modal matrix.
6. List the advantages of State Space representations?
7. Describe State and State Variable.
8. Define State equation.
9. Analyze the concept of Controllability.
10. Summarize Sampled –data Control System.
11. Mention the advantages of State Space approach?
12. Explain Alias in sampling process?
13. State sampling theorem.
14. Mention the need for State variables.
15. Illustrate Observability of the System.
16. Design the Nyquist contour for the Pole which lie at origin.
17. Illustrate closed loop sampled data systems.
18. Analyze the term Compensation.
19. Examine Open loop sampled data systems.
20. Distinguish type and order of the system.

PART B

1. Mention in detail a state space representation of a continuous time systems and discrete time systems.
2. Examine how controllability and observability for a system can be tested, with an example.
3. A system is represented by state equation $\dot{X} = AX + BU$; $Y = CX$

Where,

$$A = \begin{bmatrix} 0 & 1 & 0 \\ 0 & -1 & 1 \\ 0 & -1 & -10 \end{bmatrix}, \quad B = \begin{bmatrix} 0 \\ 0 \\ 10 \end{bmatrix}, \quad C = [1 \quad 0 \quad 0].$$

Determine the transfer

function of the system.

4. Test the controllability and observability of the system by any one method whose state space representation is given as

$$\begin{bmatrix} \dot{X}_1 \\ \dot{X}_2 \\ \dot{X}_3 \end{bmatrix} = \begin{bmatrix} 0 & 0 & 1 \\ -2 & -3 & 0 \\ 0 & 2 & -3 \end{bmatrix} \begin{bmatrix} X_1 \\ X_2 \\ X_3 \end{bmatrix} + \begin{bmatrix} X_1 \\ X_2 \\ X_3 \end{bmatrix} u$$

$$Y = [1 \quad 0 \quad 0] \begin{bmatrix} X_1 \\ X_2 \\ X_3 \end{bmatrix}.$$

5. A System is characterized by the Transfer function

$\frac{Y(s)}{U(s)} = \frac{3}{s^3 + 5s^2 + 11s + 6}$. Express whether or not the system is completely controllable and observable and identify the first state as output.

6. Discuss about the concepts of controllability and observability.
7. (i) Determine whether the system described by the following state model is completely controllable and observable

$$y(t) = [1 \quad 1 \quad 0] \begin{bmatrix} x_1(t) \\ x_2(t) \\ x_3(t) \end{bmatrix} \quad [X(t)] = \begin{bmatrix} 0 & 0 & 1 \\ -2 & -3 & 0 \\ 0 & 2 & 3 \end{bmatrix} \begin{bmatrix} x_1(t) \\ x_2(t) \\ x_3(t) \end{bmatrix} + \begin{bmatrix} 0 \\ 2 \\ 0 \end{bmatrix} u(t)$$

ii) Explain the effect of state feedback.

8. Consider the matrix A and Compute e^{At} . $A = \begin{pmatrix} 0 & 1 \\ -2 & -3 \end{pmatrix}$.

9. Obtain the state model of field controlled DC motor.

10. (i) State and prove the properties of state transition matrix and computation state matrix.

(ii) With the neat block diagram, derive the state model and its equation of a linear multi-input multi output system