



MUTHAYAMMAL ENGINEERING COLLEGE

(An Autonomous Institution)

(Approved by AICTE, New Delhi, Accredited by NAAC & Affiliated to Anna University)

Rasipuram - 637 408, Namakkal Dist., Tamil Nadu



LECTURE HANDOUTS

L - 01

MECH

Year/Sem : III / VI

Course Name : Metrology and Measurements
Unit : I

Topic of Lecture: Introduction to Metrology – Need

Introduction : (Maximum 5 sentences)

Metrology literally means science of measurements. In practical applications, it is the enforcement, verification, and validation of predefined standards.

Prerequisite knowledge for Complete understanding and learning of Topic:

The students should acquire knowledge about measuring.

The student should understand the requirements to metrology equipment.

Detailed content of the Lecture:

The important elements of a measurement is

Measurand

Reference

Comparator

1. Measurand:

It is a physical quantity or property (length, diameter, thickness, angle etc.).

2. Reference:

Reference is a physical quantity or property and comparisons are made by them.

3. Comparator:

Comparing measurand with some other reference.

The objectives of metrology and measurements include the following:

1. To ascertain that the newly developed components are comprehensively evaluated and designed within the process, and that facilities possessing measuring capabilities are available in the plant

2. To ensure uniformity of measurements

3. To carry out process capability studies to achieve better component tolerances

4. To assess the adequacy of measuring instrument capabilities to carry out their respective measurements

5. To ensure cost-effective inspection and optimal use of available facilities

6. To adopt quality control techniques to minimize scrap rate and rework

7. To establish inspection procedures from the design stage itself, so that the measuring methods are standardized

8. To calibrate measuring instruments regularly in order to maintain accuracy in measurement

9. To resolve the measurement problems that might arise in the shop floor

10. To design gauges and special fixtures required to carry out inspection

11. To investigate and eliminate different sources of measuring errors

NEED FOR INSPECTION

Inspection is defined as a procedure in which a part or product characteristic, such as a dimension, is examined to determine whether it conforms to the design specification. Basically, inspection is carried out to isolate and evaluate a specific design or quality attribute of a component or product. Industrial inspection assumed importance because of mass production, which involved interchangeability of parts. The various components that come from different locations or industries are then assembled at another place. This necessitates that parts must be so assembled that satisfactory mating of any pair chosen at random is possible. In order to achieve this, dimensions of the components must be well within the permissible limits to obtain the required assemblies with a predetermined fit. Measurement is an integral part of inspection. Many inspection methods rely on measurement techniques, that is, measuring the actual dimension of a part, while others employ the gauging method. The gauging method does not provide any information about the actual value of the characteristic but is faster when compared to the measurement technique. It determines only whether a particular dimension of interest is well within the permissible limits or not. If the part is found to be within the permissible limits, it is accepted; otherwise it is rejected. The gauging method determines the dimensional accuracy of a feature, without making any reference to its actual size, which saves time. In inspection, the part either passes or fails. Thus, industrial inspection has become a very important aspect of quality control.

Inspection essentially encompasses the following:

1. Ascertain that the part, material, or component conforms to the established or desired standard.
2. Accomplish interchangeability of manufacture.
3. Sustain customer goodwill by ensuring that no defective product reaches the customers.
4. Provide the means of finding out inadequacies in manufacture. The results of inspection are recorded and reported to the manufacturing department for further action to ensure production of acceptable parts and reduction in scrap.
5. Purchase good-quality raw materials, tools, and equipment that govern the quality of the finished products.
6. Coordinate the functions of quality control, production, purchasing, and other departments of the organizations.
7. Take the decision to perform rework on defective parts, that is, to assess the possibility of making some of these parts acceptable after minor repairs.
8. Promote the spirit of competition, which leads to the manufacture of quality products in bulk by eliminating bottlenecks and adopting better production techniques.

METHODS OF MEASUREMENTS These are the methods of comparison used in measurement process. In precision measurement various methods of measurement are adopted depending upon the accuracy required and the amount of permissible error. The methods of measurement can be classified as:

1. Direct method
2. Indirect method
3. Absolute or Fundamental method
4. Comparative method
5. Transposition method
6. Coincidence method
7. Deflection method
8. Complementary method
9. Contact method
10. Contactless method

Direct method of measurement: This is a simple method of measurement, in which the value of the quantity to be measured is obtained directly without any calculations. For example, measurements by using scales, vernier calipers, micrometers, bevel protector etc. This method is

most widely used in production. This method is not very accurate because it depends on human in sensitiveness in making judgment.

Indirect method of measurement: In indirect method the value of quantity to be measured is obtained by measuring other quantities which are functionally related to the required value. E.g. Angle measurement by sine bar, measurement of screw pitch diameter by three wire method etc.

Absolute or Fundamental method: It is based on the measurement of the base quantities used to define the quantity. For example, measuring a quantity directly in accordance with the definition of that quantity, or measuring a quantity indirectly by direct measurement of the quantities linked with the definition of the quantity to be measured.

Comparative method: In this method the value of the quantity to be measured is compared with known value of the same quantity or other quantity practically related to it. So, in this method only the deviations from a master gauge are determined, e.g., dial indicators, or other comparators.

Transposition method: It is a method of measurement by direct comparison in which the value of the quantity measured is first balanced by an initial known value A of the same quantity, and then the value of the quantity measured is put in place of this known value and is balanced again by another known value B. If the position of the element indicating equilibrium is the same in both cases, the value of the quantity to be measured is AB. For example, determination of a mass by means of a balance and known weights, using the Gauss double weighing.

Coincidence method: It is a differential method of measurement in which a very small difference between the value of the quantity to be measured and the reference is determined by the observation of the coincidence of certain lines or signals. For example, measurement by vernier caliper micrometer.

Deflection method: In this method the value of the quantity to be measured is directly indicated by a deflection of a pointer on a calibrated scale.

Complementary method: In this method the value of the quantity to be measured is combined with a known value of the same quantity. The combination is so adjusted that the sum of these two values is equal to predetermined comparison value. For example, determination of the volume of a solid by liquid displacement.

Method of measurement by substitution: It is a method of direct comparison in which the value of a quantity to be measured is replaced by a known value of the same quantity, so selected that the effects produced in the indicating device by these two values are the same.

Method of null measurement: It is a method of differential measurement. In this method the difference between the value of the quantity to be measured and the known value of the same quantity with which it is compared is brought to zero.

Video Content / Details of website for further learning (if any):

<https://www.youtube.com/watch?v=ztB7fptpp24>

Important Books/Journals for further learning including the page nos.: 4

Jain R.K, Engineering Metrology, Khanna Publishers, 2005. Page no1-4

Course Faculty

Verified by HOD



LECTURE HANDOUTS

L - 02

MECH

Year/Sem : III / VI

Course Name : Metrology and Measurements

Unit : I

Topic of Lecture: Elements – Work piece, Instruments – Persons– Environment

Introduction : A measuring system exists to provide information about the physical value of some variable being measured. In simple cases, the system can consist of only a single unit that gives an output reading or signal according to the magnitude of the unknown variable applied to it.

Prerequisite knowledge for Complete understanding and learning of Topic:

Sensors

Variable conversion elements

Processing of Signals

Signal Transmission

Recording of Signals

Detailed content of the Lecture:

Elements :

In more complex measurement situations, a measuring system consists of several separate elements as shown in Figure

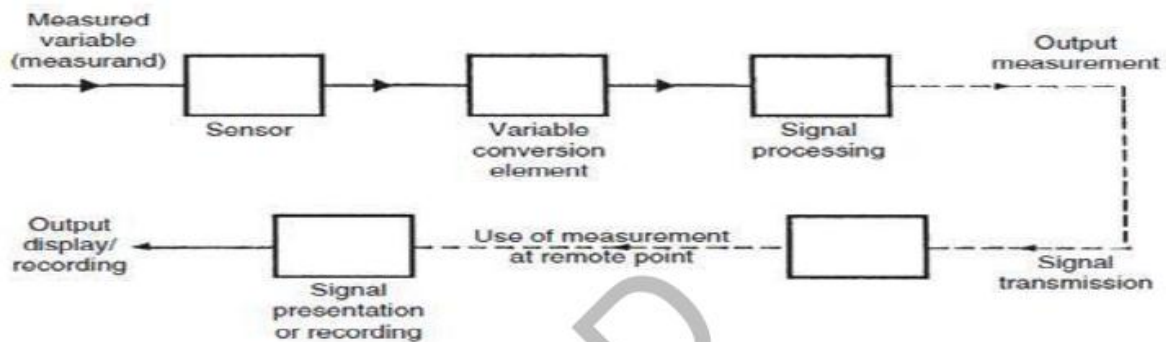

The various elements of measurement system are,

- Primary sensing Element
- Variable conversion element.
- Variable manipulation element
- Data transmission element.
- Data processing Element
- Data presentation element.

a. Primary sensing Element

It is the first element which receives energy from the measured medium and it produces an output corresponding to the measurand. This output is then converted into an analogous electrical signal by a transducer.

b. Variable conversion element. It converts the output electrical signal of the primary sensing element into a more suitable form signal without changing the information containing in the input signal. In some instruments, there is no need of using a variable conversion element while some other instruments require the variable conversion element.

c. Variable manipulation element

This element is used to manipulate the signal presented to it and preserving the original nature of the signal. In other words, it amplifies the input signal to the required magnification. For example an electronic voltage amplifier receives a small voltage as input and it produces greater magnitude of voltage as output. A variable manipulation element does not necessarily follow a variable conversion element and it may precede it.

d. Data transmission element. It transmits the data from one element to the other. It may be as shaft and gear assembly system or as complicated as a telemetry system which is used to transmit the signal from one place to another.

e. Data processing Element It is an element which is used to modify the data before displayed or finally recorded. It may be used for the following purposes. To convert the data into useful form To separate the signal hidden in noise It may provide corrections to the measured physical variables to compensate for zero offset, temperature error, scaling etc

f. Data presentation element. These are the elements that they finally communicate the information of measured variables to a human observer for monitoring, controlling or analyzing purposes. The value of measured variables may be indicated by an analog indicator, digital indicator, or by a recorder

Standard: The most basic element of measurement is a standard. A known accurate measure of physical quantity is termed as standard

Work piece: It is the part on which measurement is performed

Instruments: Device with the help of which the measurement is done.

Persons: Person responsible to carry out the measurement.

Environment: The conditions at which the measurements is carried out.

Video Content / Details of website for further learning (if any):

https://www.youtube.com/watch?v=EXy59_uuOFI

Important Books/Journals for further learning including the page nos.:

Jain R.K, Engineering Metrology, Khanna Publishers, 2005 Page no4-6

Course Faculty

Verified by HOD



MUTHAYAMMAL ENGINEERING COLLEGE

(An Autonomous Institution)

(Approved by AICTE, New Delhi, Accredited by NAAC & Affiliated to Anna University)

Rasipuram - 637 408, Namakkal Dist., Tamil Nadu



LECTURE HANDOUTS

L - 03

MECH

Year/Sem : III / VI

Course Name : Metrology and Measurements

Unit : I

Topic of Lecture: Effect on Precision and Accuracy

Introduction : Accuracy refers to how closely the measured value of a quantity corresponds to its "true" value. Precision expresses the degree of reproducibility or agreement between repeated measurements. The more measurements you make and the better the precision, the smaller the error will be.

Prerequisite knowledge for Complete understanding and learning of Topic:

Able to measure

Interpret data

Analyze data

Report of data

Detailed content of the Lecture:

Precision

The terms precision and accuracy are used in connection with the performance of the instrument.

Precision is the repeatability of the measuring process. It refers to the group of measurements for the same characteristics taken under identical conditions. It indicates to what extent the identically performed measurements agree with each other. If the instrument is not precise it will give different (widely varying) results for the same dimension when measured again and again. These observations will scatter about the mean. The scatter of these measurements is designated as σ , the standard deviation. It is used as an index of precision. The less the scattering, the more precise is the instrument. Thus, lower the value of σ , the more precise is the instrument.

Accuracy: Accuracy is the degree to which the measured value of the quality characteristic agrees with the true value. The difference between the true value and the measured value is known as error of measurement. It is practically difficult to measure exactly the true value and therefore a set of observations is made whose mean value is taken as the true value of the quality measured.

Distinction between Precision and Accuracy

Accuracy is very often confused with precision though much different. The distinction between the precision and accuracy will become clear by the following example. Several measurements are made on a component by different types of instruments (A, B and C respectively) and the results are plotted. In any set of measurements, the individual measurements are scattered about the mean, and the precision signifies how well the various measurements performed by same instrument on the same quality characteristic agree with each other. The difference between the mean of set of readings on the same quality characteristic and the true value is called as error.

Less the error more accurate is the instrument. Figure shows that the instrument A is precise since the results of number of measurements are close to the average value. However, there is a large difference (error) between the true value and the average value hence it is not accurate. The readings taken by the instruments are scattered much from the average value and hence it is not precise but accurate as there is a small difference between the average value and true value.

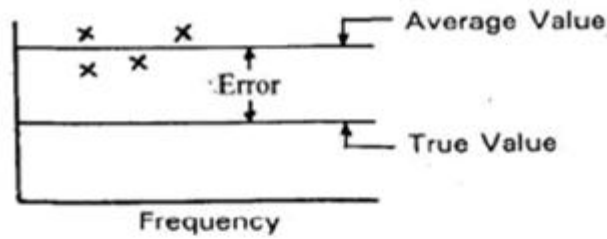

(a) Precise but not accurate

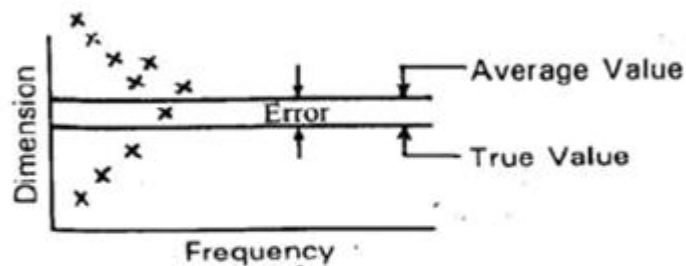

(b) Accurate but not precise

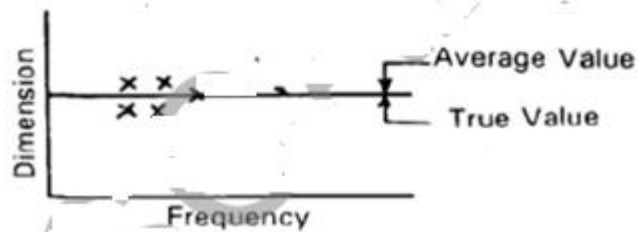

(c) Accurate & precise

Video Content / Details of website for further learning (if any):

<https://www.youtube.com/watch?v=KEeSQvMCPLg>

Important Books/Journals for further learning including the page nos.:

Jain R.K, Engineering Metrology, Khanna Publishers, 2005 Page no:9-10

Course Faculty

Verified by HOD



MUTHAYAMMAL ENGINEERING COLLEGE

(An Autonomous Institution)

(Approved by AICTE, New Delhi, Accredited by NAAC & Affiliated to Anna University)

Rasipuram - 637 408, Namakkal Dist., Tamil Nadu



LECTURE HANDOUTS

L - 04

MECH

Year/Sem : III / VI

Course Name : Metrology and Measurements

Unit : I

Topic of Lecture: Errors – Errors in Measurements - Types – Control

Introduction : ERRORS IN MEASUREMENTS It is never possible to measure the true value of a dimension there is always some error. The error in measurement is the difference between the measured value and the true value of the measured dimension.

Error in measurement = Measured value-True value

Prerequisite knowledge for Complete understanding and learning of Topic:
(Max. Four important topics)

Detailed content of the Lecture:

The errors can be classified into

- | | | |
|-------------------|---|-----------------------|
| 1. Static errors | } | Characteristic errors |
| | | Reading errors |
| | | Environmental errors |
| 2. Loading errors | | |
| 3. Dynamic error | | |

1. Static error:

It is from the physical nature of the various components of measuring system. The static errors due to environmental effect and other properties which influence the apparatus also reason for static errors.

a) Characteristic error:

The deviation of the output of the measuring system from the nominal performance specifications is called characteristic error. The linearity, repeatability, hysteresis and resolution are part of the characteristic error.

b) Reading errors:

It is exclusively applied to the read out device. The reading error describes the factors parallax error and interpolation error. The use of mirror behind the readout indicator eliminates the occurrence of parallax error. Interpolation error is a reading error resulting from the inexact evaluation of the position ' of index.

(c) Environmental errors:

Every instrument is manufactured and calibrated at one place and it is used in some other place where the environmental conditions such as temperature, pressure, and humidity are changes.

2. Loading errors:

Loading means the measuring instrument always takes input from the signal source. Due to this, the signal source will always be altered by the act of measurement known loading. Example: If steam flow through the nozzle, it is very difficult to find the perfect flow rate. This is called loading error.

3. Dynamic error:

This is due to time variations in the measurand. The dynamic errors are caused by inertia, friction and clamping action. The dynamic errors are mainly classified into

- a) Systematic errors or Controllable errors.
- b) Random errors.

a) Systematic errors:

The systematic are constant and similar in form. These are controllable in both their sense and magnitude. The systematic errors are easily determined and reduced, hence these are also called as controllable errors.

Systematic errors includes

1. Calibration errors.
2. Ambient or Atmospheric conditions
3. Avoidable errors.
4. Stylus pressure;

1. Calibration errors:

Calibration is a process of giving a known input to the measurement system and also taking necessary actions to see that the out of the measurement system matches with its input.

If the instrument is not calibrated, the instrument will show very high degree of error.

2. Ambient errors:

This is due to variation in atmospheric conditions (Example: Pressure. Temperature and moisture) normally the instruments are calibrated at particular pressure and temperatures. Temperature will not be equal at all places. If the temperature and pressure varies, the ambient error will be formed. Standard temperature of 20°C and pressure of 760mm Hg is taken as ambient condition.

3. Avoidable errors:

This type of error due to parallax, non-alignment of work piece centers, and improper location of measuring instrument. For example placing a thermometer in sunlight for measuring air temperature will cause the Instrument location error.

4. Stylus pressure:

Whenever a component measured under pressure the deformation of the work piece and surface deflection will occur. The pressure involved is generally small but this is sufficient to cause appreciable deformation on stylus and the work piece

b) Random errors:

These types of errors occurs Randomly and reason for this type of errors cannot be specified.

The source for this type of errors are

1. Displacement of level joints in the measuring instrument.
2. Small variation in the position of settings.
3. Reading scale error due to operator.

CAUSES OF ERRORS

1. Calibration error:

These are caused due to the variation in the calibrated scale from its normal value.

2. Environment errors:

These errors are caused due to humidity condition, temperature, and altitude.

3. Assembly errors:

The assembly errors are due to 1.. Displaced scale i.e. incorrect fitting of the scale. 2. Nonuniform division of the scale. 3. Due to heni or distorted pointer.

4. Random errors:

There is no specific reason for causing of Random errors. It may naturally occur.

5. Systematic errors (or) Bias errors:

These type of errors caused due to repeated readings.

6. Chaotic errors:

Chaotic errors are caused due to vibrations, noises, and shocks.

Video Content / Details of website for further learning (if any):

https://www.youtube.com/watch?v=EF_Fv1_D3Tk

Important Books/Journals for further learning including the page nos.:

Jain R.K, Engineering Metrology, Khanna Publishers, 2005 Page no25-30

Course Faculty

Verified by HOD



MUTHAYAMMAL ENGINEERING COLLEGE

(An Autonomous Institution)

(Approved by AICTE, New Delhi, Accredited by NAAC & Affiliated to Anna University)

Rasipuram - 637 408, Namakkal Dist., Tamil Nadu



LECTURE HANDOUTS

L - 05

MECH

Year/Sem : III / VI

Course Name : Metrology and Measurements

Unit : I

Topic of Lecture: Types of Standards

Introduction : A standard provides a reference for assigning a numerical value to a measured quantity

Prerequisite knowledge for Complete understanding and learning of Topic:

Errors

Measurements

Calibration

Detailed content of the Lecture:

Standards The term standard is used to denote universally accepted specifications for devices. Components are processes which ensure conformity and interchangeability throughout a particular industry. A standard provides a reference for assigning a numerical value to a measured quantity. Each basic measurable quantity has associated with it an ultimate standard. Working standards, those used in conjunction with the various measurement making instruments.

The national institute of standards and technology (NIST) formerly called National Bureau of Standards (NBS), it was established by an act of congress in 1901, and the need for such body had been noted by the founders of the constitution. The following is the generalization of echelons of standards in the national measurement system.

1. Calibration standards
2. Metrology standards
3. National standards

Calibration standards: Working standards of industrial or government all laboratories.

Metrology standards: Reference standards of industrial or Government all laboratories.

National standards: It includes proto type and natural phenomenon of SI (Systems International), the world wide system of weight and measures standards. Application of precise measurement has increased so much, that a single national laboratory to perform directly all the calibrations and standardization required by large country with high technical development.

Classification of Standards To maintain accuracy and interchangeability it is necessary that Standards to be trace able to a single source, usually the National Standards of the country, which are further linked to International Standards. The accuracy of National Standards is transferred to working standards through a chain of intermediate standards in a manner given below.

- National Standards
- National Reference Standards

- Working Standards
- Plant Laboratory Reference Standards
- Plant Laboratory Working Standards
- Shop Floor Standards

For linear measurements the standards known are

- Line standard
- End standard
- Wave length standard

LINE STANDARD

A yard (or) meter is defined as the distance between scribed lines on a bar of metal under certain conditions of temperature and supports.

The yard is defined as 0.9144 meter

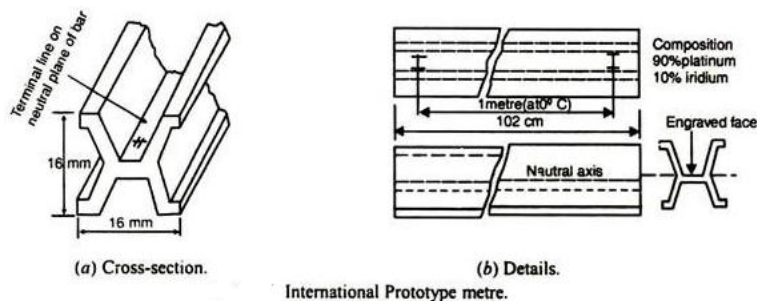
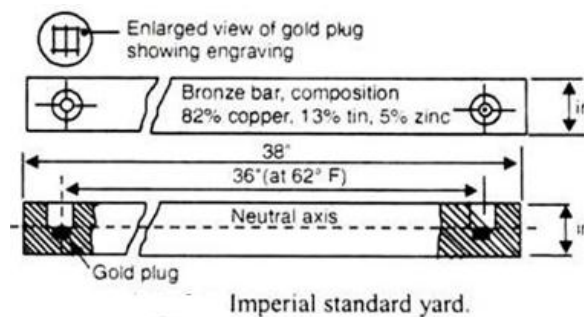

END STANDARD

End standard in the form of bars and slip gauges are general use in precision engineering as well as in standard such as the N.P.L.

WAVE LENGTH STANDARD

In this standard, the wave length of the monochromatic light is used as a unit of length.

Video Content / Details of website for further learning (if any):

<https://www.youtube.com/watch?v=gMsLRkQrYhk>

Important Books/Journals for further learning including the page nos.:

Jain R.K, Engineering Metrology, Khanna Publishers, 2005 Page no 47-49

Course Faculty

Verified by HOD



MUTHAYAMMAL ENGINEERING COLLEGE

(An Autonomous Institution)

(Approved by AICTE, New Delhi, Accredited by NAAC & Affiliated to Anna University)

Rasipuram - 637 408, Namakkal Dist., Tamil Nadu



LECTURE HANDOUTS

L - 06

MECH

Year/Sem : III / VI

Course Name : Metrology and Measurements

Unit : II

Topic of Lecture: Linear Measuring Instruments – Evolution

Introduction : Linear measurement includes the measurement of lengths, diameters, heights and thickness. Non-precision instruments include steel rule, caliper divider, and telescopic gauge that are used to measure to the line graduations of a rule.

Prerequisite knowledge for Complete understanding and learning of Topic:

Measurements

Units

Scale (1:2)

Detailed content of the Lecture:

MEASUREMENT OF ENGINEERING COMPONENTS:

Measurement systems are mainly used in industries for quality control management.

Often quality control engineers are applying some the measuring systems such as linear and angular measurements.

These measurements are very much useful to compare the actual measurements with already existing standard measurements.

The linear measurement includes the measurement of lengths, diameters, heights and thickness.

The basic principle of linear measurement is that of comparison with standard dimensions on a suitably engraved instrument or device.

The various devices used for measuring the linear measurements are

- Vernier calipers
- Micrometers
- Slip gauge or gauge blocks
- Comparators

Angular measurement is another important element in measuring.

This involves the measurement of angles of tapers and similar surfaces. In angular measurements t types of angle measuring devices are used.

They are angle gauges corresponding to slip gauges and divided scales corresponding to line standards. The most common instrument is sine bar.

The main difference between linear and angular measurement is that no absolute standard is required for angular measurement.

SCALES:

The most common tool for crude measurements is the scale (also known as rules, or rulers)

Although plastic, wood and other materials are used for common scales, precision scales use tempered steel alloys, with graduations scribed onto the surface.

These are limited by the human eye. Basically they are used to compare two dimensions.

The metric scales use decimal divisions, and the imperial scales use fractional divisions.



Some scales only use the fine scale divisions at one end of the scale.

It is advised that the end of the scale not be used for measurement. This is because as they become worn with use, the end of the scale will no longer be at a 'zero' position.

Instead the internal divisions of the scale should be used.

Parallax error can be a factor when making measurements with a scale.

Video Content / Details of website for further learning (if any):

<https://www.youtube.com/watch?v=SOHTg9EFE5g>

Important Books/Journals for further learning including the page nos.:

Jain R.K, Engineering Metrology, Khanna Publishers, 2005 Page no97-95

Course Faculty

Verified by HOD

LECTURE HANDOUTS

L - 07

MECH

Year/Sem : III / VI

Course Name : Metrology and Measurements

Unit : II

Topic of Lecture: Types of Linear Measuring Instruments

Introduction : The various Linear Measuring Instruments are Vernier Caliper, Micrometer, Vernier Height Gauge and Vernier Depth Gauge.

Prerequisite knowledge for Complete understanding and learning of Topic:
Measurements, Standards, Least Count

Detailed content of the Lecture:

A vernier calliper consists of two main parts: the main scale engraved on a solid L-shaped frame and the vernier scale that can slide along the main scale. The sliding nature of the vernier has given it another name—sliding calliper. The main scale is graduated in millimetres, up to a least count of 1 mm. The vernier also has engraved graduations, which is either a forward vernier or a backward vernier. The vernier calliper is made of either stainless steel or tool steel, depending on the nature and severity of application. Figure illustrates the main parts of a vernier calliper. The L-shaped main frame also serves as the fixed jaw at its end. The movable jaw, which also has a vernier scale plate, can slide over the entire length of the main scale, which is engraved on the main frame or the beam. A clamping screw enables clamping of the movable jaw in a particular position after the jaws have been set accurately over the job being measured.

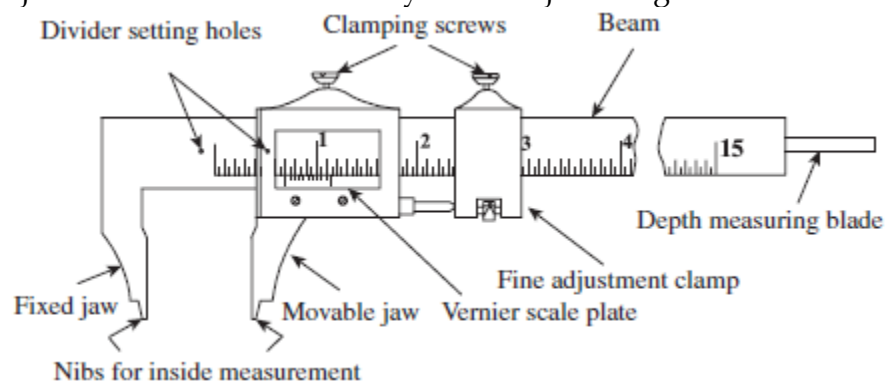

The micrometer has an accurate screw having about 10 to 20 threads/cm and revolves in a fixed nut. The end of the screw is one tip and the other is constructed by a stationary anvil.

$\text{LEAST COUNT} = \text{Pitch scale division} / \text{Number of threads}$

$\text{Pitch scale division} = \text{Distance moved} / \text{number of rotation}$

Uses:

- Outside micrometer is used to measure the diameter of solid cylinder.
- Inside micrometer is used to measure the internal diameters of hollow cylinders and spheres.

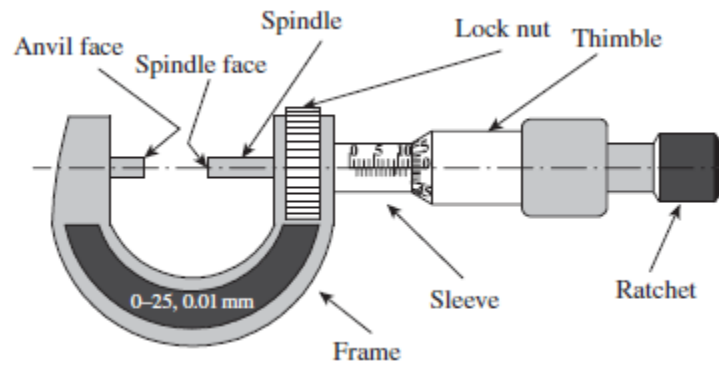

Depth gauge is the preferred instrument for measuring holes, grooves, and recesses. It basically consists of a graduated rod or rule, which can slide in a T-head (simply called the head) or stock. The rod or rule can be locked into position by operating a screw clamp, which facilitates accurate reading of the scale. Figure illustrates a depth gauge, which has a graduated rule to read the measurement directly. The head is used to span the shoulder of a recess, thereby providing the reference point for measurement. The rod or rule is pushed into the recess until it bottoms.

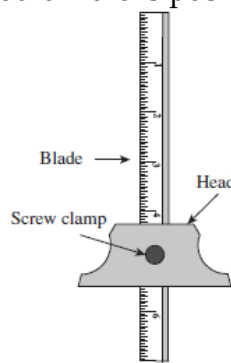

In a vernier height gauge, as illustrated in Figure, the graduated scale or bar is held in a vertical position by a finely ground and lapped base. A precision ground surface plate is mandatory while using a height gauge. The feature of the job to be measured is held between the base and the measuring jaw. The measuring jaw is mounted on a slider that moves up and down, but can be held in place by tightening of a nut. A fine adjustment clamp is provided to ensure very fine movement of the slide in order to make a delicate contact with the job.

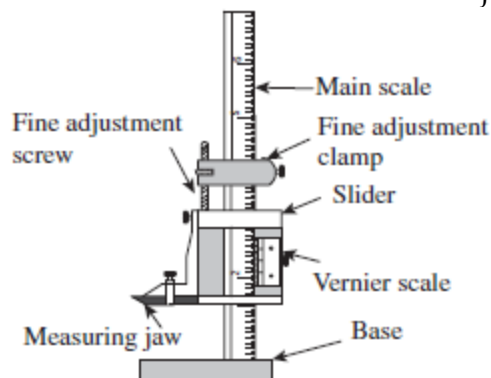

Video Content / Details of website for further learning (if any):

<https://www.youtube.com/watch?v=mI0R8qfeRhM>

Important Books/Journals for further learning including the page nos.:

Jain R.K, Engineering Metrology, Khanna Publishers, 2005 Page no 134-142

Course Faculty

Verified by HOD



LECTURE HANDOUTS

L - 08

MECH

Year/Sem : III / VI

Course Name : Metrology and Measurements

Unit : II

Topic of Lecture: Classification of Linear Measuring Instruments

Introduction : steel rule can measure accurately up to 1 mm or at best up to 0.5 mm. It is not sensitive to variations in dimensions at much finer levels because of the inherent limitation in its design. On the other hand, vernier instruments based on the vernier scale principle can measure up to a much finer degree of accuracy.

Prerequisite knowledge for Complete understanding and learning of Topic:

Least Count, Measurement

Detailed content of the Lecture:

Types of Vernier Calipers According to Indian Standard IS:3651- 1974, three types of vernier calipers have been specified to make external and internal measurements and are shown in figures respectively. All the three types are made with one scale on the front of the beam for direct reading.

Type A :Vernier has jaws on both sides for external and internal measurements and a blade for depth measurement.

Type B: It is provided with jaws on one side for external and internal measurements.

Type C: It has jaws on both sides for making the measurement and for marking operations

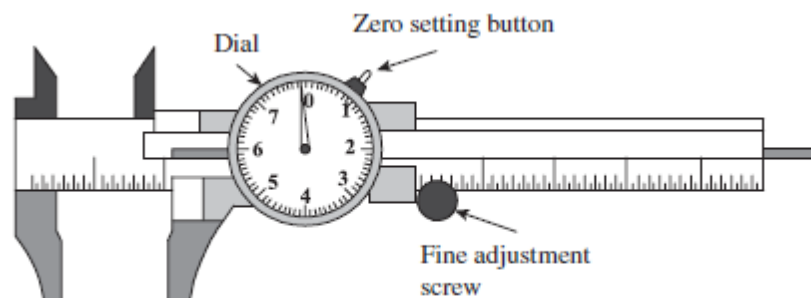

Vernier Dial Caliper

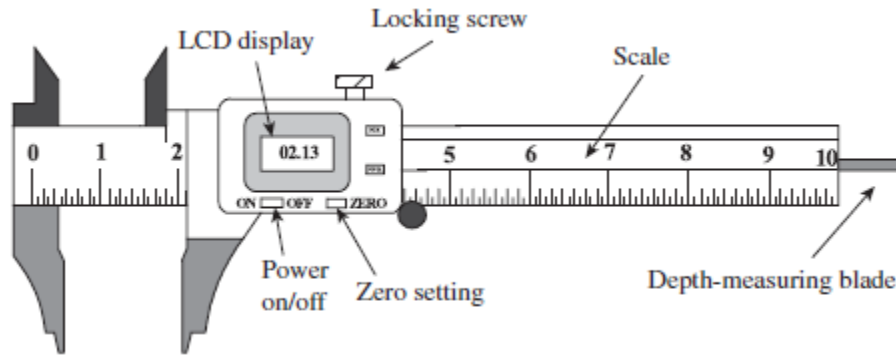

Vernier Electronic Caliper

Micrometer

There are two types in it.

□ Outside micrometer – To measure external dimensions.

□ Inside micrometer – To measure internal dimensions

An outside micrometer is shown. It consists of two scales, main scale and thimble scale. While the pitch of barrel screw is 0.5mm the thimble has graduation of 0.01mm. The least count of this micrometer is 0.01 mm.

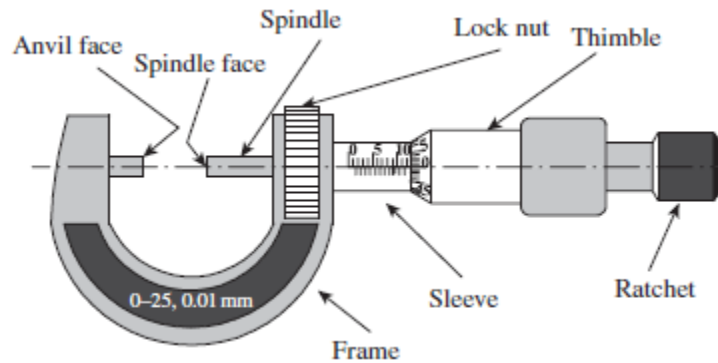

Outside Micrometer

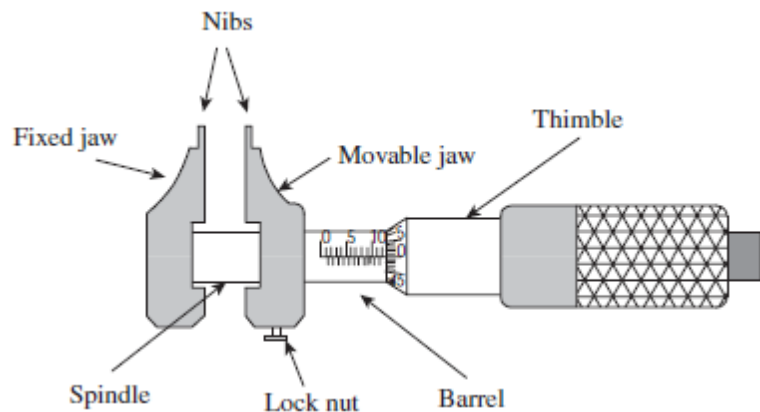

Inside Micrometer

Video Content/ Details of website for further learning (if any):

<https://www.youtube.com/watch?v=mI0R8qfeRhM>

Important Books/Journals for further learning including the page nos.:

Jain R.K, Engineering Metrology, Khanna Publishers, 2005 Page no 144-155

Course Faculty

Verified by HOD



MUTHAYAMMAL ENGINEERING COLLEGE

(An Autonomous Institution)

(Approved by AICTE, New Delhi, Accredited by NAAC & Affiliated to Anna University)

Rasipuram - 637 408, Namakkal Dist., Tamil Nadu



LECTURE HANDOUTS

L - 09

MECH

Year/Sem : III / VI

Course Name : Metrology and Measurements

Unit : II

Topic of Lecture: Limit gauges – gauge design – terminology – procedure

Introduction : Depending on usage, a gauge can be described as "a device for measuring a physical quantity", for example "to determine thickness, gap in space, diameter of materials, or pressure of flow", or "a device that displays the measurement of a monitored system by the use of a needle or pointer that moves along a calibrated.

Prerequisite knowledge for Complete understanding and learning of Topic:

Standard

Inspection

Calibration

Detailed content of the Lecture:

SLIP GAUGES These may be used as reference standards for transferring the dimension of the unit of length from the primary standard to gauge blocks of lower accuracy and for the verification and graduation of measuring apparatus. These are high carbon steel hardened, ground and lapped rectangular blocks, having cross sectional area of 30mm, 10mm. Their opposite faces are flat, parallel and are accurately the stated distance apart. The opposite faces are of such a high degree of surface finish, that when the blocks are pressed together with a slight twist by hand, they will wring together. They will remain firmly attached to each other. They are supplied in sets of 112 pieces down to 32pieces.

Due to properties of slip gauges, they are built up by, wringing into combination which gives size, varying by steps of 0.01 mm and the overall accuracy is of the order of 0.00025mm. Slip gauges with three basic forms are commonly found, these are rectangular, square with center hole, and square without center hole.

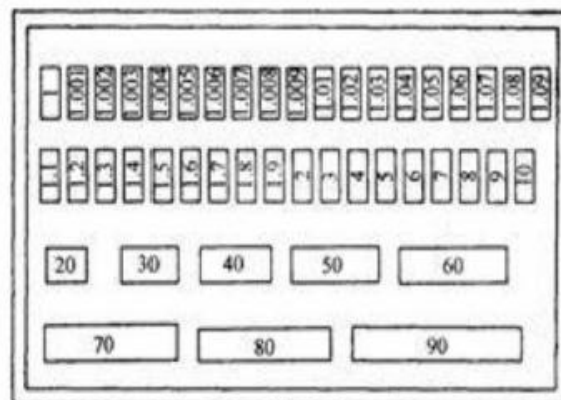
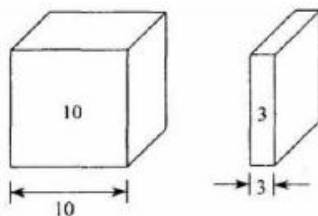

Slip Gauges

Precautions

The blocks should be kept in the box and it should not be dropped on the irregular surfaces.

Surfaces of slip gauges should be cleaned before it is used.

The slip gauge block should be in particular temperature condition to eliminate the thermal expansion which causes inaccuracy during measurement.

While using slip gauges for measurement it should be kept on a flat surface to get high accurate readings.

LIMIT GAUGES

A limit gauge is not a measuring gauge. Just they are used as inspecting gauges.

The limit gauges are used in inspection by methods of attributes.

This gives the information about the products which may be either within the prescribed limit or not.

By using limit gauges report, the control charts of P and C charts are drawn to control invariance of the products.

This procedure is mostly performed by the quality control department of each and every industry.

Limit gauges are mainly used for checking for cylindrical holes of identical components with a large number in mass production.

Purpose of using limit gauges

Components are manufactured as per the specified tolerance limits, upper limit and lower limit. The dimension of each component should be within this upper and lower limit. If the dimensions are outside these limits, the components will be rejected. It is just enough whether the size of the component is within the prescribed limits or not. For this purpose, we can make use of gauges known as limit gauges.

“Limit gauging is a method of checking dimensions in which a fixed gauge is applied to the work in order to determine whether a given component lies within its limits.” Gauges are inspection tools of rigid design, without a scale, which are used to check the dimensions of manufactured components. The various limit gauges are

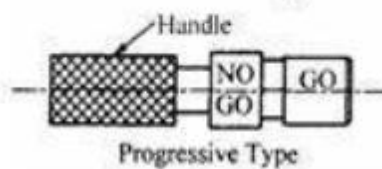
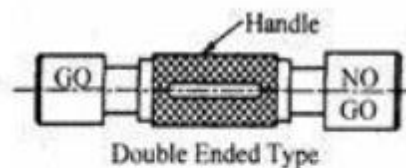

Plug Gauges

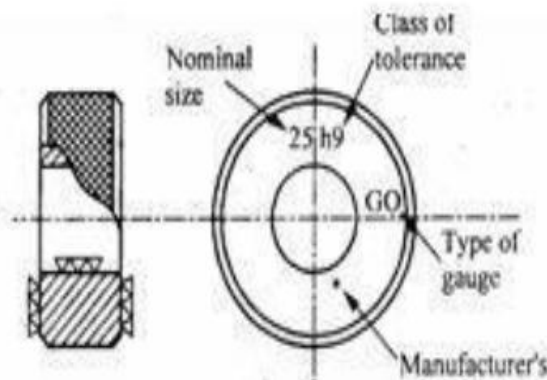

Ring Gauge

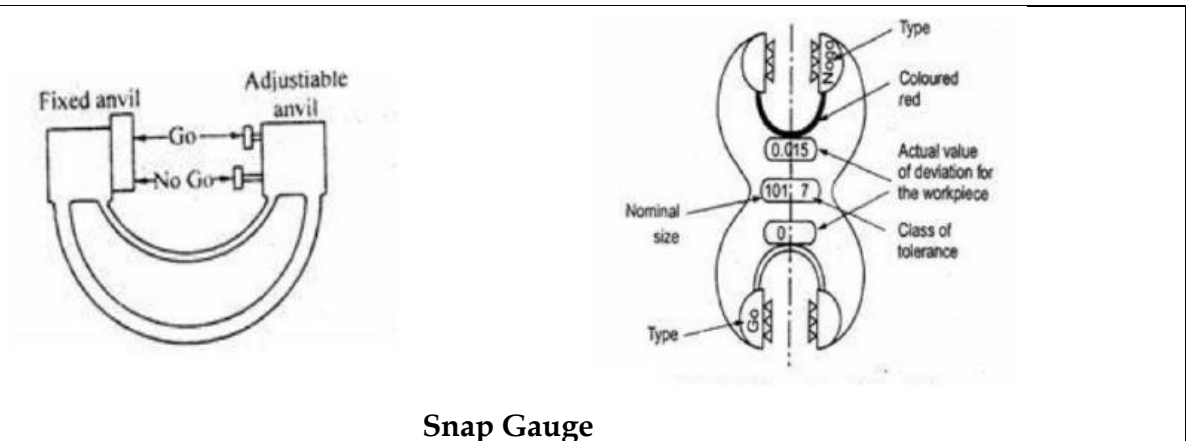

Snap Gauge

Video Content / Details of website for further learning (if any):

<https://www.youtube.com/watch?v=dTT9Z49LSeg>

Important Books/Journals for further learning including the page nos.:

Jain R.K, Engineering Metrology, Khanna Publishers, 2005 Page no 205-210

Course Faculty

Verified by HOD



MUTHAYAMMAL ENGINEERING COLLEGE

(An Autonomous Institution)

(Approved by AICTE, New Delhi, Accredited by NAAC & Affiliated to Anna University)

Rasipuram - 637 408, Namakkal Dist., Tamil Nadu



LECTURE HANDOUTS

L - 10

MECH

Year/Sem : III / VI

Course Name : Metrology and Measurements

Unit : II

Topic of Lecture: Concepts of interchangeability and selective assembly

Introduction : Interchangeability can refer to: Interchangeable parts, the ability to select components for assembly at random and fit them together within proper tolerances.

Prerequisite knowledge for Complete understanding and learning of Topic:

Fits and Tolerance

Dimensioning

Assembly of parts

Detailed content of the Lecture:

Interchangeability

- An interchangeable part is one which can be substituted for similar part manufactured to the same drawing.
- In earlier times production used to be confined to small number of units and the same operator could adjust the mating components to obtain desired fit.
- With time the concept of manufacturing techniques kept on changing and today the same operator is no more responsible for manufacture and assembly too.
- With economic oriented approach, mass production techniques were inevitable, that led to breaking up of a complete process into several smaller activities and this led to specialization.
- As a result various mating components will come from several shops; even a small component would undergo production on several machines.
- Under such conditions it becomes absolutely essential to have strict control over the dimensions of portions which have to match with other parts.
- Any one component selected at random should assemble correctly with any other mating component that too selected at random.
- When a system of this kind is ensured it is known as interchangeable system. Interchangeability ensures increased output with reduced production cost.
- In interchangeable system, every operator being concerned only with a limited portion of overall work, he can easily specialize himself in that work and give best results leading to superior quality.
- He need not waste his skill in fitting the components by hit and trial and assembly time is reduced considerably.
- In the case of big assemblies, several units to manufacture individual parts can be located in different parts of country depending on availability of specialized labour, raw material, power, water and other facilities and final assembly of all individual components manufactured in several units can be done at one place.

- The replacement of worn out or defective parts and repairs is rendered very easy and the cost of maintenance is very much reduced and shut down time also reduced to minimum.
- Interchange ability is possible only when certain standards are strictly followed.
- Universal interchange ability (i.e. parts drawn from any two altogether different manufacturing sources for mating purposes) is desirable and for this it is essential that common standards be followed by all, and all standards used by various manufacturing units should be traceable to a single source, i.e. international standards.
- When all parts to be assembled are made in the same manufacturing unit, local standards may be followed (condition being known as local interchange ability) but for reasons of obtaining spares from any other source it is again desirable that these local standards be also traceable to international standards.
- The required fit in an assembly can be obtained in two ways, namely Universal or full interchange ability, and **Selective assembly**.
- Full interchangeability means that any component will mat with any other mating component without classifying manufactured components in subgroup o without carrying out any minor alterations for mating purposes.
- This type of interchange ability is not must for interchangeable production and many times not feasible also as it requires machines capable of maintaining high process capability and very high accuracy, and very close supervision on production from time to time.
- For full interchangeable assembly it is essential that only such machines be selected for manufacturing whose process capability is equal to or less than the manufacturing tolerance allowed for that part.
- Only then every component will be within desired tolerance and capable of mating with any other mating component.

Video Content / Details of website for further learning (if any):

https://www.youtube.com/watch?v=8Lol_2M2WXc

Important Books/Journals for further learning including the page nos.:

Jain R.K, Engineering Metrology, Khanna Publishers, 2005 Page no 267-270

Course Faculty

Verified by HOD



MUTHAYAMMAL ENGINEERING COLLEGE

(An Autonomous Institution)

(Approved by AICTE, New Delhi, Accredited by NAAC & Affiliated to Anna University)

Rasipuram - 637 408, Namakkal Dist., Tamil Nadu



LECTURE HANDOUTS

L - 11

MECH

Year/Sem : III / VI

Course Name : Metrology and Measurements

Unit : II

Topic of Lecture: Angular measuring instruments – Types

Introduction : Line standard gives direct angular measurement from the engraved scales in the instruments. They are not very precise. Hence they are not used when high precision is required. However, they can be used in initial estimation of the angles in measurement. We will discuss some of the line standard angular measuring devices.

Prerequisite knowledge for Complete understanding and learning of Topic:

Dimensioning
Slip Gauges
Trigonometry

Detailed content of the Lecture:

ANGULAR MEASUREMENT

The concept of Angle comes from the circle. Actually, Angle is a part of a circle. We measure an angle in Degree or Radian. Usually, the primary objective of angle measurement is not to measure angles but the assessment of the alignment of machine parts or products.

Angle is defined as the opening between two lines which meet at a point.

In a current scenario, there is a wide range of angle measuring instruments available, from simple scaled instruments to complex types of techniques.

Some Basic Angle Measuring Instruments are

Bevel Protractor
Digital Protractor
Sine Bar

Spirit Level

- Vernier Protractor

A Vernier Protractor is an instrument, provided with a mechanical support or a simple mechanism to position them accurately against the given work-piece and lock the reading.

- Spirit Level

A Spirit Level has universal applications, for aligning structural members such as beams and columns in various engineering fields.

- Conventional/Electronic Clinometers

Conventional or Electronic Clinometers are instruments employing the basic principle of a spirit

level but with higher resolution.

Collimators and Angle Dekkors are the most precise instruments.

- Protractor

A simple protractor is a basic device used for measuring angles with a least count of 1° or $1/2^\circ$ with limited usage. A few additions and a simple mechanism, which can hold the main scale, a vernier scale, and blade, can make it very versatile.

Types of bevel protectors:

1. Universal bevel protractor
2. Optical bevel protractor

Video Content / Details of website for further learning (if any):

<https://www.youtube.com/watch?v=a397Wilm9GA>

Important Books/Journals for further learning including the page nos.: 517

Jain R.K, Engineering Metrology, Khanna Publishers, 2005

Course Faculty

Verified by HOD



LECTURE HANDOUTS

L - 12

MECH

Year/Sem : III / VI

Course Name : Metrology and Measurements

Unit : II

Topic of Lecture: Bevel protractor, Clinometers

Introduction : Bevel protractor is used for measuring and laying out angles accurately and precisely within 5 minutes. A clinometer is a tool used for measuring angles of a slope.

Prerequisite knowledge for Complete understanding and learning of Topic:

Measuring Instruments

Basic Drawings

Detailed content of the Lecture:

Bevel protractor is used for measuring and laying out angles accurately and precisely within 5 minutes. The protractor dial is slotted to hold a blade which can be rotated with the dial to the required angle and also independently adjusted to any desired length. The blade can be locked in any position.

It is the simplest instrument for measuring the angle between two faces of component. It consists of base plate attached to the main body and an adjustable blade which is attached to a circular plate containing vernier scale. The adjustable blade is capable of rotating freely about the centre of the main scale engraved on the body of the instrument and can be locked in any position. It is capable of measuring from 0 to 360°. The vernier scale has 24 divisions. Coinciding with 23 main scale divisions. Thus the least count of the instrument is 5'. This instrument is commonly used in workshop for angular measurements.

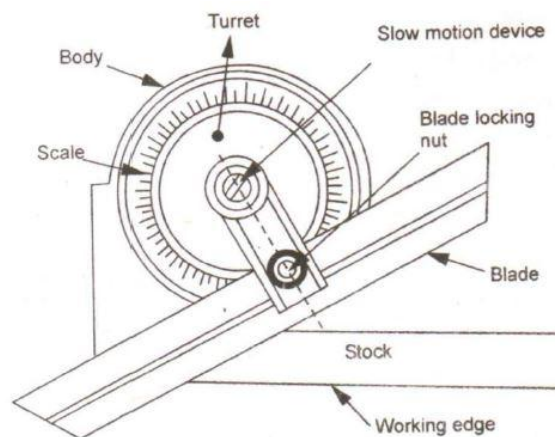

Bevel Protractor

The clinometer is an optical device for measuring elevation angles above horizontal. The most common instruments of this type currently used are compass-clinometers from Suunto or Silva.

Compass clinometers are fundamentally just magnetic compasses held with their plane vertical so that a plummet or its equivalent can point to the elevation of the sight line. A better clinometer (I believe) is the Abney hand spirit level or clinometer, where the object sighted and the level bubble can be seen simultaneously, so that the index can be set accurately. An Abney clinometer is shown in the photograph. A spirit level is so-called because it contains alcohol in a tube of large radius, in which the bubble moves to the highest point. Spirit levels are used for accurate surveying, although automatic levels that go back to the principle of the plummet are now frequently found, and are easy to use.

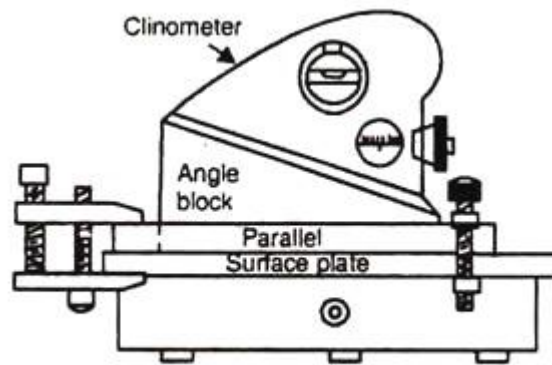

Fig. 1.26. (e) The clinometer.

Video Content / Details of website for further learning (if any):

<https://www.youtube.com/watch?v=6FcKwQ2KUYE>

Important Books/Journals for further learning including the page nos.:

Jain R.K, Engineering Metrology, Khanna Publishers, 2005 Page no 518,532

Course Faculty

Verified by HOD

LECTURE HANDOUTS

L - 13

MECH

Year/Sem : III / VI

Course Name : Metrology and Measurements

Unit : I

Topic of Lecture: Angle gauges, Spirit levels sine bar

Introduction : Angles are measured using a sine bar with the help of gauge blocks and a dial Gauge or a spirit level. The aim of a measurement is to measure the surface on which the dial gauge or spirit level is placed horizontally. For example, to measure the angle of a wedge, the wedge is placed on a horizontal table

Prerequisite knowledge for Complete understanding and learning of Topic:

Measuring Instruments

Accuracy and precision

Principles

Detailed content of the Lecture:

Angles gauges, like slip gauges are blocks of hardened steel approximately 75mm long and 16mm wide. They differ from slip gauges in the sense that their working surfaces are not parallel to each other, but are at an angle, engraved on them. For measuring angles, angle gauges are more accurate than the sine bar. They are enables to measure any angle between 0 degrees and 360 degrees with an accuracy of 0.5 to 0.25 second.

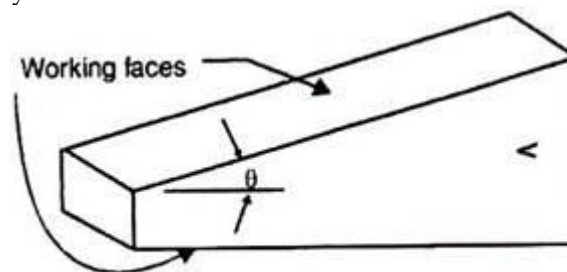

Fig. 1.25. An angle gauge.

The angle blocks may be wrong together in various combinations, just like slip gauges. One end of each angle block is marked plus, while the opposite end is marked minus. They are so designed that they may be combined in plus or minus positions. Two narrow ends together provide addition of individual angles, while narrow ends lies opposite to each other provide subtraction of angles. The following figures show the process of preparation of desired angle.

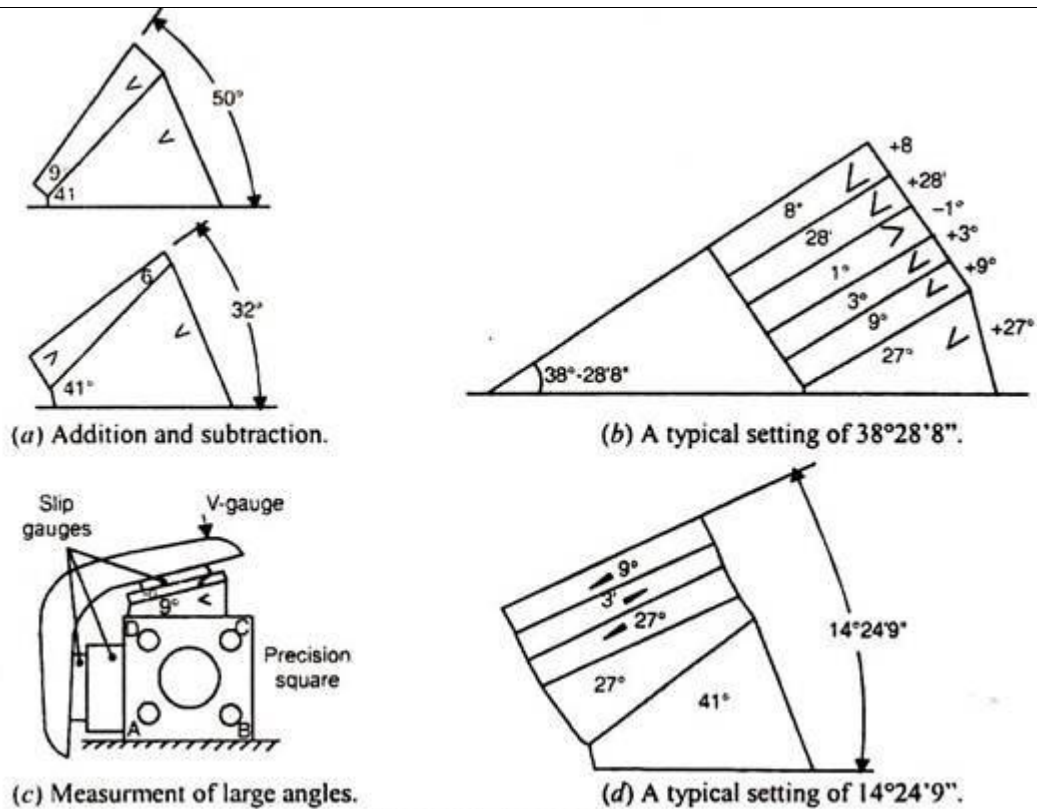

Fig. 1.26. Angle gauges.

Spirit level is one of the most commonly used instruments for inspecting the horizontal position of surfaces and for evaluating the direction and magnitude of minor deviation from that nominal condition. It essentially consists of a close glass tube of accurate form. It is called as the vial. It is filled almost entirely with a liquid, leaving a small space for the formation of an air or gas bubble. Generally, low viscosity fluids, such as ether, alcohol or benzol, are preferred for filling the vial. The liquid due to its greater specific weight tends to fill the lower portion of the closed space. Upper side of the vial is graduated in linear units. Inclination of a surface can be known from the deviation of the bubble from its position when the spirit level is kept in a horizontal plane.

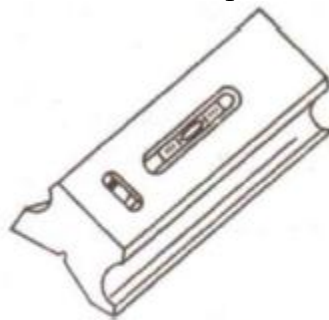
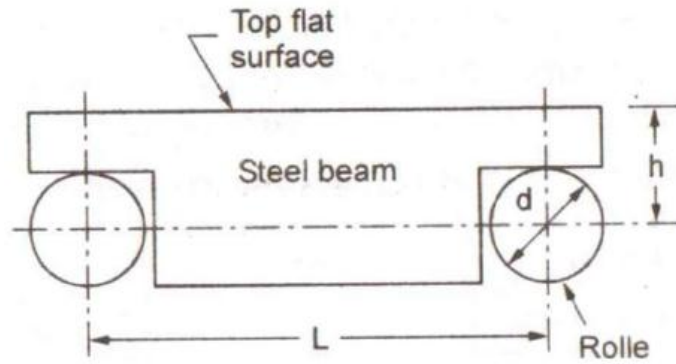

Figure 6.5 : Spirit Level

A sine bar is made up of a hardened steel beam having a flat upper surface. The bar is mounted on two cylindrical rollers. These rollers are located in cylindrical grooves specially provided for the purpose. The axes of the two rollers are parallel to each other. They are also parallel to the upper flat surface at an equal distance from it.



Sine Bar

It is specified by the distance between the two centres of two rollers. The high degree of accuracy and precision available for length measurement in the form of slip and block gauges may be utilized for measurement of angle using the relationship

$$\sin \theta = \frac{h}{L}$$

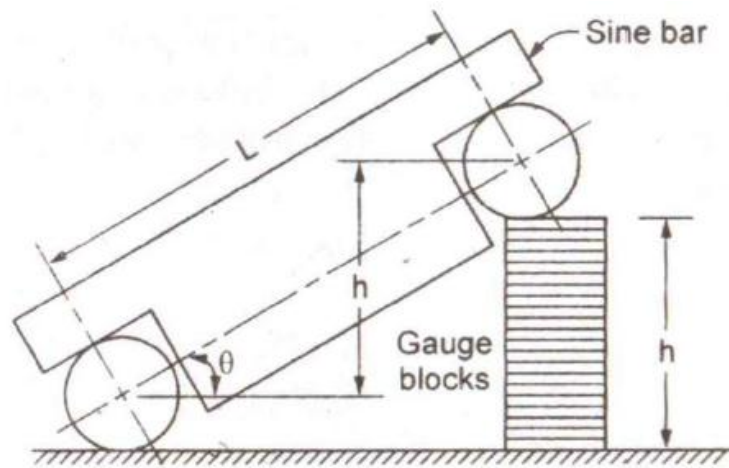

Video Content / Details of website for further learning (if any):

https://www.youtube.com/watch?v=xM_JfToSrXA

Important Books/Journals for further learning including the page nos.: 524-526

Jain R.K, Engineering Metrology, Khanna Publishers, 2005

Course Faculty

Verified by HOD



MUTHAYAMMAL ENGINEERING COLLEGE

(An Autonomous Institution)

(Approved by AICTE, New Delhi, Accredited by NAAC & Affiliated to Anna University)

Rasipuram - 637 408, Namakkal Dist., Tamil Nadu



LECTURE HANDOUTS

L - 14

MECH

Year/Sem : III / VI

Course Name : Metrology and Measurements

Unit : II

Topic of Lecture: Angle alignment telescope

Introduction : Highly precise Instrument to align machine bores, bearings and optical Instrument line of sight axis. Linear shift up to 30 m measured in both axes with precision Micrometer with 20 microns Resolution. Prisms India offers a wide range of targets suit specific applications.

Prerequisite knowledge for Complete understanding and learning of Topic:

Prisms and Lens

Opticals

Precision and accuracy

Detailed content of the Lecture:

Applications

Bore Alignment Checks

Machine Tool Straightness and alignment checks

Turbine installation and maintenance

Flatness Checking and setting of bed plates

Ship building repairs and maintenance

Alignment of Rollers of process industries

Aircraft Jig setting and control

Tool Alignment of Large Boring Machines

Main bearing Alignment of large Engines

The equipment consists of :

- Focusable telescope locates in the shot end.
- Illuminated Target Collimator locates in the Platen end.
- Target Collimator is equipped with two cross hairs for close distance and for infinity.
- Measurement of linear shifts and angular tilts.
- Makeup sleeves may be required when fitting onto a range of machines.
- Custom made collimators are also available

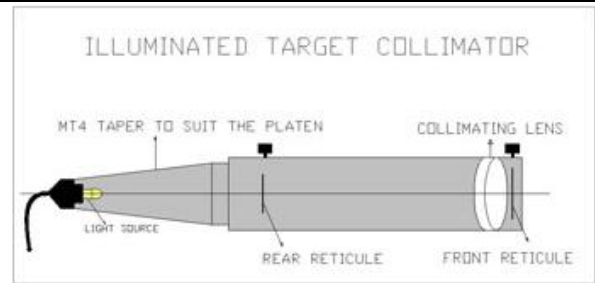

Specifications

Linear Resolution: 20 μm

Readout: Dual Axis Micrometer

Linear Measuring Range: ± 1.2 mm

Linear Measuring Accuracy: ± 0.020 mm +2% displacement

Line of Sight Error: < 10 μm over 3m, < 100 μm over 30m

Concentricity of Mechanical axis to Optical Axis: < 10 μm

Parallelism of Optical Axis and Barrel: < 5 Secs

Image: Erect

Magnification: 43X

Accuracy of Focus Scale: 10%

Clear Aperture: 25 mm

Barrel Diameter: 57.145 -0.010, +0 mm

Barrel Length: 350 mm

Overall Length: 530 mm

Focus Range: 0 mm to Infinity

Weight: Approx 6 Kgs

Video Content / Details of website for further learning (if any):

<https://www.youtube.com/watch?v=rGjKOErZUZU>

Important Books/Journals for further learning including the page nos.: 540

Jain R.K, Engineering Metrology, Khanna Publishers, 2005

Course Faculty

Verified by HOD

LECTURE HANDOUTS

L - 15

MECH

Year/Sem : III / VI

Course Name : Metrology and Measurements

Unit : II

Topic of Lecture: Autocollimator – Applications.

Introduction :

The two main principles used in an autocollimator are

- the projection and the refraction of a parallel beam of light by a lens, and
- the change in direction of a reflected angle on a plane reflecting surface with change in angle of incidence.

Prerequisite knowledge for Complete understanding and learning of Topic:

Optics

Measurements

Analytical skills

Detailed content of the Lecture:

To understand this, let us imagine a converging lens with a point source of light O at its principle focus, as shown in Figure 6.7(a). When a beam of light strikes a flat reflecting surface, a part of the beam is absorbed and the other part is reflected back. If the angle of incidence is zero, i.e. incident rays fall perpendicular to the reflecting surface, the reflected rays retrace original path. When the reflecting plane is tilted at certain angle, the total angle through which the light is deflected is twice the angle through which the mirror is tilted. Thus, alternately, if the incident rays are not at right angle to the reflecting surface they can be brought to the focal plane of the light sources by tilting the reflecting plane at an angle half the angle of reflection as shown in Figure 6.7(b).

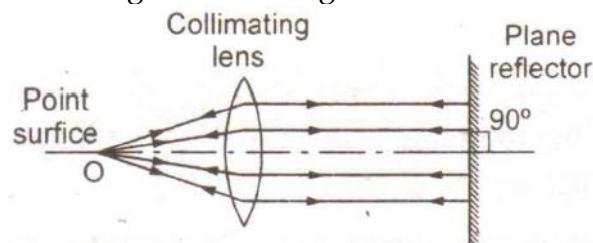

(a) Reflector is at 90° with the Direction of Rays

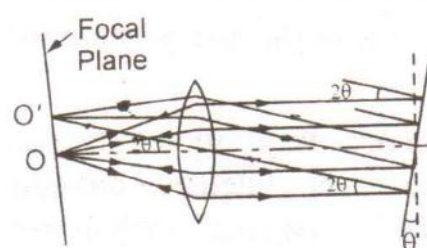

Figure 6.7(b) : Reflector is not at Right Angles to the Direction of the Rays

$$OO' = 2\theta \times f = x,$$

Now, from the diagram, f is the focal length of the lens.

Thus, by measuring the linear distance x , the inclination of the reflecting surface can be determined. The position of the final image does not depend upon the distance of the reflector from the lens. If, however, the reflector is moved too long, the reflected ray will then completely miss the lens and no image will be formed.

Working

In actual practice, the work surface whose inclination is to be obtained forms the reflecting surface and the displacement x is measured by a precision microscope which is calibrated directly to the values of inclination.

The optical system of an autocollimator is shown in Figure 6.8. The target wires are illuminated by the electric bulb and act as a source of light since it is not convenient to visualize the reflected image of a point and then to measure the displacement x precisely. The image of the illuminated wire after being reflected from the surface being measured is formed in the same plane as the wire itself. The eyepiece system containing the micrometer microscope mechanism has a pair of setting lines which may be used to measure the displacement of the image by setting to the original cross lines and then moving over to those of the image.

Generally, a calibration is supplied with the instrument. Thus, the angle of inclination of the reflecting surface per division of the micrometer scale can be directly read.

Autocollimators are quite accurate and can read up to 0.1 seconds, and may be used for distance up to 30 meters.

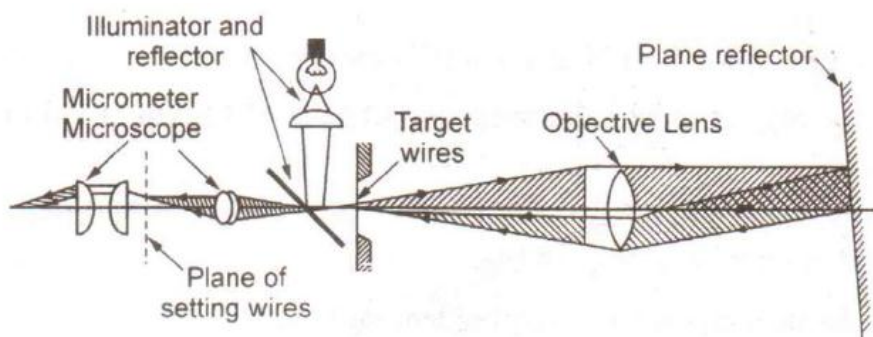

Figure 6.8 : Optical System of an Autocollimator

Video Content / Details of website for further learning (if any):

<https://www.youtube.com/watch?v=2cmaTVCUnjM>

Important Books/Journals for further learning including the page nos.:

Jain R.K, Engineering Metrology, Khanna Publishers, 2005 Page no:534-535

Course Faculty

Verified by HOD



MUTHAYAMMAL ENGINEERING COLLEGE

(An Autonomous Institution)

(Approved by AICTE, New Delhi, Accredited by NAAC & Affiliated to Anna University)

Rasipuram - 637 408, Namakkal Dist., Tamil Nadu



LECTURE HANDOUTS

L - 16

MECH

Year/Sem : III / VI

Course Name : Metrology and Measurements

Unit : III

Topic of Lecture: Basic concept of lasers, Advantages of lasers

Introduction :

Laser stands for **Light Amplification by Stimulated Emission of Radiation**. Laser instrument is a device to produce powerful, monochromatic, collimated beam of light in which the **waves are coherent**.

Prerequisite knowledge for Complete understanding and learning of Topic:

Measurement, Laser Production

Detailed content of the Lecture:

Laser development is for production of clear coherent light. The advantage of coherent light is that whole of the energy appears to be emanating from a very small point. The beam can be focused easily into either a parallel beam or onto a very small point by use of lenses. A major impact on optical measurement has been made by development in elector optics, providing automation, greater acuity of setting and faster response time. Radiation sources have developed in a number of areas; the most important developments are light emitting diodes and lasers. The laser is used extensively for interferometry particularly the He- Ne gas type. The laser distance measuring interferometer has become an industry standard. This produces 1 to 2mm diameter beam of red light power of 1MW and focused at a point of very high intensity. The beam begins to expand at a rate of 1mm/m. The laser beam is visible and it can be observed easily. This is used for very accurate measurements of the order of 0.1µm are 100m.

Types of laser light sources

(a).Optically pumped solid state laser

- Ruby laser
- Nd:YAG laser
- Nd:Glass laser

(b).Liquid (Dye) laser

(c).Gas laser

- Helium-Neon laser
- Argon ion laser
- Krypton laser
- Carbon dioxide laser
- Excimer laser

(d).Semiconductor laser

(e).X-ray laser

(f).Chemical laser

Components/elements of laser

- Active medium
- Excitation mechanism
- High reflector mirror
- Partially transmission mirror

Laser Metrology

Metrology lasers are low power instruments. Most are helium-neon type. Wave output laser that emit visible or infrared light. He-Ne lasers produce light at a wavelength of $0.6\mu\text{m}$ that is in phase, coherent and a thousand times more intense than any other monochromatic source. Laser systems have wide dynamic range, low optical cross talk and high contrast. Laser find application in dimensional measurements and surface inspection because of the properties of laser light. These are useful where precision, accuracy, rapid non-contact gauging of soft, delicate or hot moving points

Advantages of laser in Metrology

- High precision and accurate measurements are possible.
- Fast data acquisition is possible without the potential distortion.
- Laser instruments have few moving parts.
- There are no contact and hot moving parts. Hence it ensures higher durability and longevity.
- Improvement in quality of manufacturing is ensured as absolute reference are used for measurement

Video Content / Details of website for further learning (if any):

<https://www.youtube.com/watch?v=UheTIVwukWg>

Important Books/Journals for further learning including the page nos.:

Jain R.K, Engineering Metrology, Khanna Publishers, 2005 Page no: 1106

Course Faculty

Verified by HOD



MUTHAYAMMAL ENGINEERING COLLEGE

(An Autonomous Institution)

(Approved by AICTE, New Delhi, Accredited by NAAC & Affiliated to Anna University)

Rasipuram - 637 408, Namakkal Dist., Tamil Nadu



LECTURE HANDOUTS

L - 17

MECH

Year/Sem : III / VI

Course Name : Metrology and Measurements

Unit : III

Topic of Lecture: Laser Interferometers – Types

Introduction :

Interferometer uses a laser as light source and thus used to measure large distance, the laser beam wavelength is exact and pure for highly accurate measurements.

Prerequisite knowledge for Complete understanding and learning of Topic:

Laser-Production & its Application

Detailed content of the Lecture: It is possible to maintain the quality of interference fringes over longer distance when lamp is replaced by a laser source. Laser interferometer uses AC laser as the light source and the measurements to be made over longer distance. Laser is a monochromatic optical energy, which can be collimated into a directional beam AC. Laser interferometer (ACLI) has the following advantages.

- ☑ High repeatability
- ☑ High accuracy
- ☑ Long range optical path
- ☑ Easy installations
- ☑ Wear and tear

Schematic arrangement of laser interferometer is shown in fig. Two-frequency zeeman laser generates light of two slightly different frequencies with opposite circular polarisation. These beams get split up by beam splitter B. One part travels towards B and from there to external cube corner here the displacement is to be measured.

Laser Interferometer :

This interferometer uses cube corner reflectors which reflect light parallel to its angle of incidence. Beam splitter B2 optically separates the frequency f_1 which alone is sent to the movable cube corner reflector. The second frequency from B2 is sent to a fixed reflector which then rejoins f_1 at the beam splitter B2 to produce alternate light and dark interference flicker at about 2 Mega cycles per second. Now if the movable reflector moves, then the returning beam frequency Doppler-shifted slightly up or down by Δf . Thus the light beams moving towards photo detector P2 have frequencies f_2 and $(f_1 \pm \Delta f)$ and P2 changes these frequencies into electrical signal. Photo detector P2 receive signal from beam splitter B2 and changes the reference beam frequencies f_1 and f_2 into electrical signal. An AC amplifier A separates frequency. Difference signal $f_2 - f_1$ and A2 separates frequency difference signal. The pulse converter extracts i. one cycle per half wavelength of motion. The up-down pulses are counted electronically and displayed in analog or digital form.

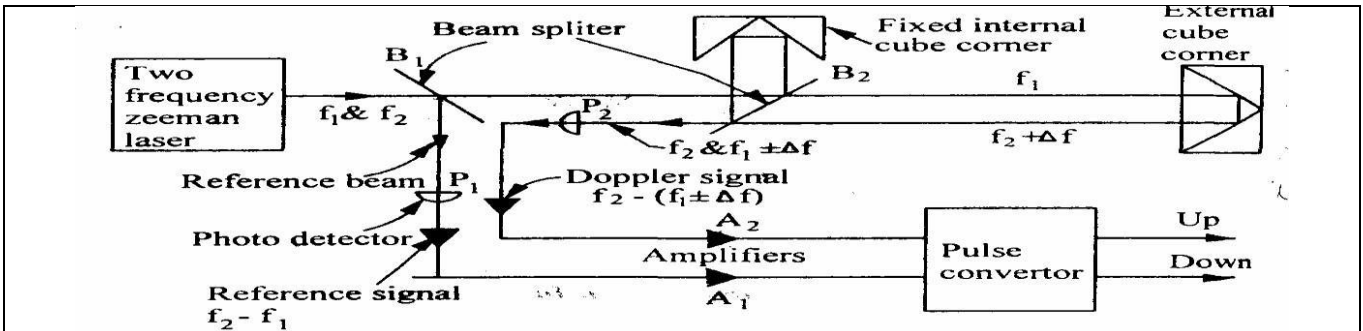

Laser Interferometers

This interferometer uses cube corner reflectors which reflect light parallel to its angle of incidence. Beam splitter B2 optically separates the frequency J which alone is sent to the movable cube corner reflector. The second frequency from B2 is sent to a fixed reflector which then rejoins f_1 at the beam splitter B2 to produce alternate light and dark interference flicker at about 2 Mega cycles per second. Now if the movable reflector moves, then the returning beam frequency Doppler-shifted slightly up or down by Δf . Thus the light beams moving towards photo detector P2 have frequencies f_2 and $(f_1 \pm \Delta f)$ and P2 changes these frequencies into electrical signal. Photo detector P2 receive signal from beam splitter B2 and changes the reference beam frequencies f_1 and f_2 into electrical signal. An AC amplifier A separates frequency. Difference signal $f_2 - f_1$ and A2 separates frequency difference signal. The pulse converter extracts i. one cycle per half wavelength of motion. The up-down pulses are counted electronically and displayed in analog or digital form.

Video Content / Details of website for further learning (if any):

<https://www.youtube.com/watch?v=IPbcSd33zCA>

Important Books/Journals for further learning including the page nos.:

Jain R.K, Engineering Metrology, Khanna Publishers, 2005 Page no: 435, 535

Course Faculty

Verified by HOD



LECTURE HANDOUTS

L - 18

MECH

Year/Sem : III / VI

Course Name : Metrology and Measurements

Unit : III

Topic of Lecture: DC and AC Lasers interferometer

Introduction :

AC Laser Interferometer uses two frequency laser systems, thus overcoming the shortcoming of d.c. laser interferometer. Whereas the d.c. system mixes out of phase light beams of the same frequency, the a.c. system mixes beams of two different frequencies thus permitting the distance information to be carried on a.c. waveform. Use is made of the fact that the AC amplifiers are insensitive to d.c. variation of a.c. inputs.

Prerequisite knowledge for Complete understanding and learning of Topic:

Applications of Laser

Detailed content of the Lecture:

Laser Interferometer It is possible to maintain the quality of interference fringes over longer distance when lamp is replaced by a laser source: Laser interferometer uses AC laser as the light source and the measurements to be made over longer distance. Laser is a monochromatic optical energy, which can be collimated into a directional beam AC. Laser interferometer (ACLI) has the following advantages. 1. High repeatability 2. High accuracy 3. Long range optical path 4. Easy installations 5. Wear and tear Schematic arrangement of laser interferometer is shown in fig. Two-frequency Zeeman laser generates light of two slightly different frequencies with opposite circular polarizations. These beams get split up by beam splitter B One part travels towards B and from there to external cube corner here the displacement is to be measured.

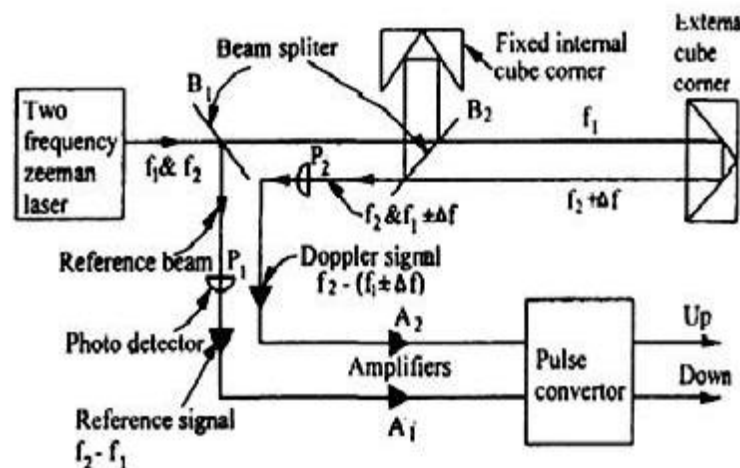

This interferometer uses cube corner reflectors which reflect light parallel to its angle of incidence. Beam splitter B2 optically separates the frequency f_1 which alone is sent to the movable cube corner reflector. The second frequency f_1 from B2 is sent to a fixed reflector which then rejoins f_1 at the beam splitter B2 to produce alternate light and dark interference flicker at about 2 Megacycles per

second. Now if the movable reflector moves, then the returning beam frequency Doppler-shifted slightly up or down by (f_1) . Thus the light beams moving towards photo detector P2 have frequencies f_2 and $(f_1 \pm f_1)$ and P2 changes these frequencies into electrical signal. Photo detector P2 receive signal from beam splitter B2 and changes the reference beam frequencies f_1 and f_2 into electrical signal. An AC amplifier A1 separates frequency difference signal $f_2 - f_1$ and A2 separates frequency difference signal $[f_2 - (f_1 \pm f_1)]$. The pulse converter extracts f , one cycle per half wavelength of motion. The up-down pulses are counted electronically and displayed in analog or digital form

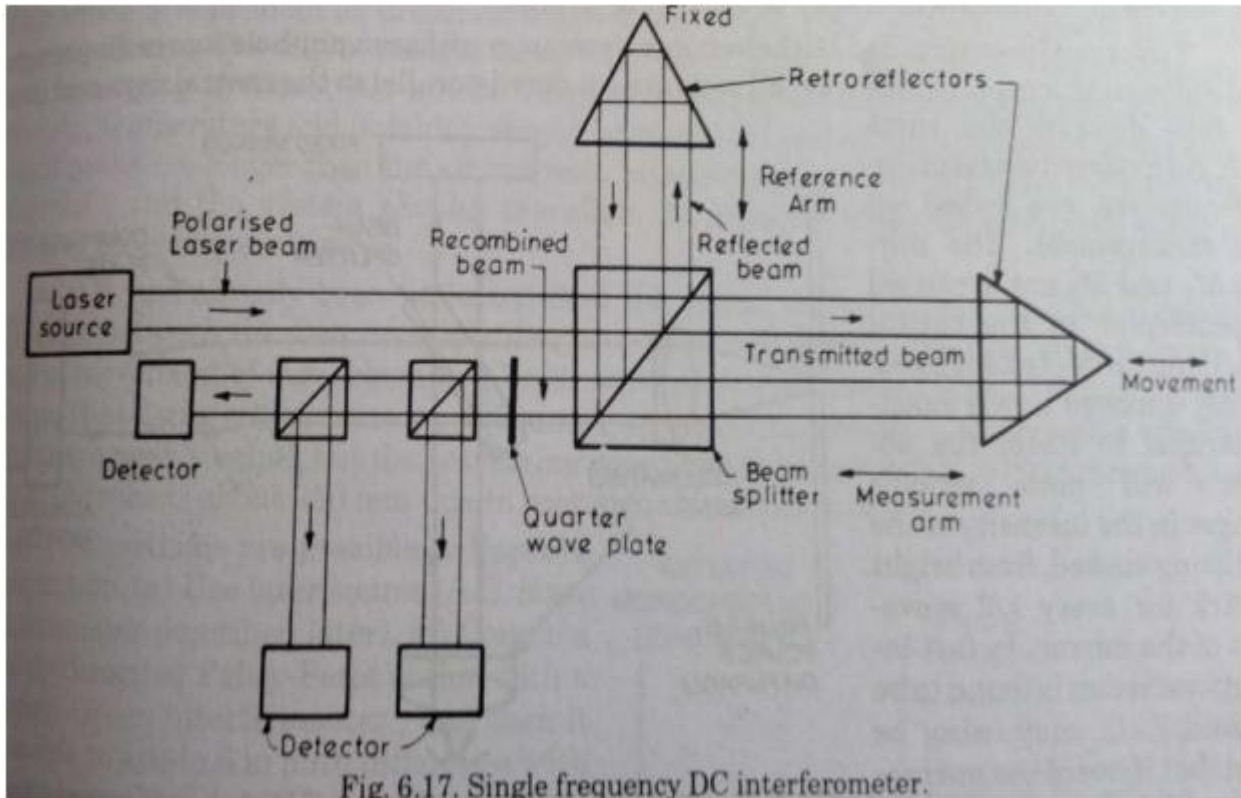

The DC laser interferometer uses a single frequency circular frequency circular polarized laser beam .the single arrangements of various components when it is reached the beam splitter. They travel to their retroreflector and then they are reflected back towards the beam splitter.

Video Content / Details of website for further learning (if any):

<https://www.youtube.com/watch?v=jB7suji-fCY>

Important Books/Journals for further learning including the page nos.:

Jain R.K, Engineering Metrology, Khanna Publishers, 2005 Page no: 427

Course Faculty

Verified by HOD



MUTHAYAMMAL ENGINEERING COLLEGE

(An Autonomous Institution)

(Approved by AICTE, New Delhi, Accredited by NAAC & Affiliated to Anna University)

Rasipuram - 637 408, Namakkal Dist., Tamil Nadu



LECTURE HANDOUTS

L - 19

MECH

Year/Sem : III / VI

Course Name : Metrology and Measurements

Unit : III

Topic of Lecture: Applications of Interferometers

Introduction :

Interferometer is used in Flatness measurement, Straightness Testing etc

Prerequisite knowledge for Complete understanding and learning of Topic:

Interferometer - Types

Detailed content of the Lecture:

Flatness is defined as the geometrical concept of a perfect plane. It is an important function in construction of many technical components where accuracy is a required criterion. For example, controlled flatness is required to provide full contact with a mating part. Flatness is a precondition for the parallelism of nominally flat surface. It is a reliable boundary plan for linear dimension. It also provides locating planes for dependable mounting or assembly of manufactured parts. Considering the functional role of flatness, the measurement of that condition on the operating surface of manufactured parts is often an important operation of the dimensional inspection process. There are various methods and instruments available for measuring the flatness of a plane. The choice of the best-suited method is governed by various factors, such as size and shape of the part, the area to be inspected, its accessibility and intersection with other surfaces and the desired degrees of measuring accuracy. Interferometry is one of the precise methods for calculation of flatness. In this method monochromatic light is allowed to fall on an optical flat which in turn is placed on the surface at small angle whose flatness is to be calculated. Optical flats are transparent, flat, circular section of small thickness usually made of clear fused quartz or pyrex. The optical flat is placed on the surface to be inspected in such a way as to create interference bands observable under monochromatic light. The resulting band pattern permits the object's flatness conditions to be evaluated. The principle is explained below. When optical flat is placed on the surface plate, it makes a very small angle to it. Monochromatic light of known wavelength is allowed to fall on it. This is shown in Figure 9.2. Part of the beam passes through the glass, strikes the flat reflecting surface, and reflected back. The other part of the beam is reflected back to air at the lower surface of the optical flat. These two beams again recombine and undergo the phenomenon of interference since they are of same wavelength. This results in formation of interference fringes as explained in Section 9.2. The position of the fringe width will depend on the separation between the surface and the lower surface of the optical flat. Considering that the angle between the surface and the optical flat is very less, the extra distance that the reflected light from the inspected surface travels is $2d$ more than the reflected light from the optical surface, where d is the separation between optical flat and the reflecting surface.

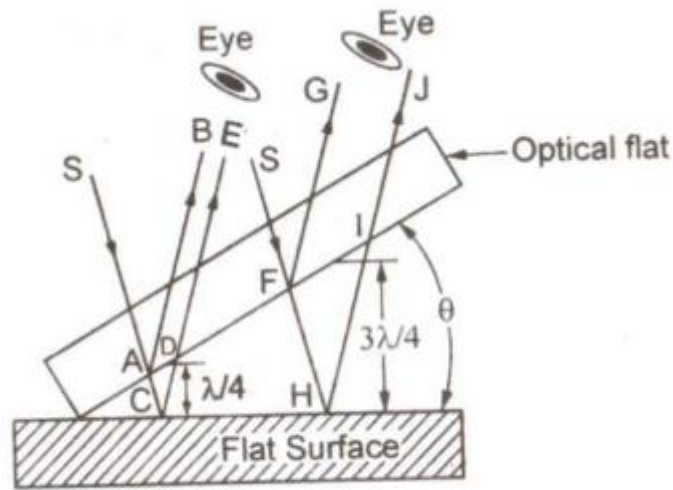

Figure 9.2

For constructive interference, the path difference between the rays should be even multiple of 2λ , where λ is the wavelength of light. i.e. $2dn\lambda = 2m\lambda$ where $n = 1, 2, 3, \dots$ i.e. $2dn\lambda = 2m\lambda$. Thus, where there is a separation of integral multiple of 2λ , bright fringes will result. On the other hand, for destructive interference, the path difference between the rays should be odd multiple of 2λ . i.e. $2dn\lambda = (2m+1)\lambda$ i.e. $4dn\lambda = (2m+1)\lambda$. Thus, the separation giving odd multiples of 4λ will result dark fringes. By studying the pattern of the fringe formed nature of the reflecting surface can be studied. A perfectly flat surface will result exactly parallel fringes without any distortion. Deviation from the perfect flatness causes digression in parallelism of the fringes proportional to flatness error

Video Content / Details of website for further learning (if any):

<https://www.youtube.com/watch?v=Hxj327ZmPtU>

Important Books/Journals for further learning including the page nos.:

Jain R.K, Engineering Metrology, Khanna Publishers, 2005 Page no: 430

Course Faculty

Verified by HOD



MUTHAYAMMAL ENGINEERING COLLEGE

(An Autonomous Institution)

(Approved by AICTE, New Delhi, Accredited by NAAC & Affiliated to Anna University)
Rasipuram - 637 408, Namakkal Dist., Tamil Nadu



LECTURE HANDOUTS

L - 20

MECH

Year/Sem : III / VI

Course Name : Metrology and Measurements

Unit : III

Topic of Lecture: Straightness – Alignment

Introduction :
Accurate production of the component parts depends on the accuracy of the machine tools. The accuracy of machine Tools depends on Alignment of Machine parts

Prerequisite knowledge for Complete understanding and learning of Topic:
1. The straight line represents the path of all linear dimensions.
2. Learn more about *Straightness* Measurement

Detailed content of the Lecture:
Laser Equipment for Alignment Testing
This testing is particularly suitable in aircraft production, shipbuilding etc. Where a number of components, spaced long distance apart, have to be checked to a predetermined straight line.

OPERATING PRINCIPLES	TYPICAL INSTRUMENTS	DIAGRAM	DISCUSSION
----------------------	---------------------	---------	------------

Straightness of a surface element determined by its parallelism to a straight edge of known accuracy	Straight edge and gage blocks		Unequal height of the supporting elements create a controlled deviation from true parallelism. Gage blocks are used to check whether the digressions from the parallel at intermediate points correspond to the calculated values.
--	-------------------------------	--	--

The straightness of a surface element inspected by direct contact with a tool of calibrated straightness	Knife edge rule		A knife edge rule brought to bear against the surface element to be inspected will indicate by the presence and width of light gaps the lack of contact caused by deficient straightness.
--	-----------------	--	---

The straightness of a surface element inspected by direct contact with a tool of calibrated straightness

Knife edge rule

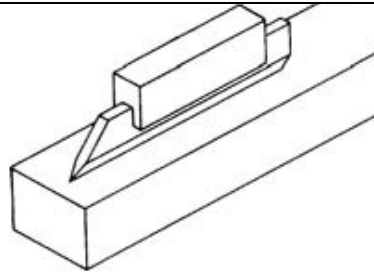

A knife edge rule brought to bear against the surface element to be inspected will indicate by the presence and width of light gaps the lack of contact caused by deficient straightness.

Straightness of a shaft determined by rotation on fixed supports and measuring the runout of its surface

Bench centers or Vee-blocks and indicator stand

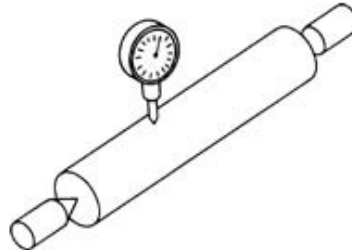

Using the part's axis (between centers) or its surface...

Other uses of laser equipment are testing of flatness of machined surfaces, checking squareness with the help of optical square etc. These consist of laser tube will produces a cylindrical beam of laser about 10mm diameter and an auto reflector with a high degree of accuracy. Laser tube consists of helium-neon plasma tube in a heat aluminum cylindrical housing. The laser beam comes out of the housing from its centre and parallel to the housing within 10'' of arc and alignment stability is the order of 0.2'' of arc per hour. Auto reflector consists of detector head and read out unit. Number of photocell are arranged to compare laser beam in each half horizontally and vertically. This is housed on a shard which has two adjustments to translate the detector in its two orthogonal measuring directions perpendicular to the laser beam. The devices detect the alignment of flat surfaces perpendicular to a reference line of sight.

Video Content / Details of website for further learning (if any):

<https://www.youtube.com/watch?v=Ny4P0EsjQxk>

Important Books/Journals for further learning including the page nos.:

Jain R.K, Engineering Metrology, Khanna Publishers, 2005 Page no: 764

Course Faculty

Verified by HOD



MUTHAYAMMAL ENGINEERING COLLEGE

(An Autonomous Institution)

(Approved by AICTE, New Delhi, Accredited by NAAC & Affiliated to Anna University)

Rasipuram - 637 408, Namakkal Dist., Tamil Nadu



LECTURE HANDOUTS

L - 21

MECH

Year/Sem : III / VI

Course Name : Metrology and Measurements

Unit : III

Topic of Lecture: Basic concept of CMM , Types of CMM

Introduction :

A **coordinate measuring machine (CMM)** is a device that measures the geometry of physical objects by sensing discrete points on the surface of the object with a probe. Various types of probes are used in **CMMS**, including mechanical, optical, laser, and white light.

Prerequisite knowledge for Complete understanding and learning of Topic:

Coordinates
Control System

Detailed content of the Lecture:

Measuring machines are used for measurement of length over the outer surfaces of a length bar or any other long member. The member may be either rounded or flat and parallel. It is more useful and advantageous than vernier calipers, micrometer, screw gauges etc. the measuring machines are generally universal character and can be used for works of varied nature. The co-ordinate measuring machine is used for contact inspection of parts. When used for computer-integrated manufacturing these machines are controlled by computer numerical control. General software is provided for reverse engineering complex shaped objects. The component is digitized using CNC, CMM and it is then converted into a computer model which gives the two surface of the component. These advances include for automatic work part alignment on the table. Savings in inspection 5 to 10 percent of the time is required on a CMM compared to manual inspection methods.

Types of Measuring Machines

1. Length bar measuring machine.
2. Newall measuring machine.
3. Universal measuring machine.
4. Co-ordinate measuring machine.
5. Computer controlled co-ordinate measuring machine.

Constructions of CMM

Co-ordinate measuring machines are very useful for three dimensional measurements. These machines have movements in X-Y-Z co-ordinate, controlled and measured easily by using touch probes. These measurements can be made by positioning the probe by hand, or automatically in more expensive machines. Reasonable accuracies are 5 micro in. or 1 micrometer. The method these machines work on is measurement of the position of the probe using linear position sensors. These are based on moiré fringe patterns (also used in other systems). Transducer is provided in tilt directions for giving digital display and senses positive and negative direction.

Types of CMM

(i) Cantilever type

The cantilever type is very easy to load and unload, but mechanical error takes place because of sag or deflection in Y-axis.

(ii) Bridge type

Bridge type is more difficult to load but less sensitive to mechanical errors.

iii) Horizontal boring Mill type

This is best suited for large heavy work pieces.

(iv) Vertical boring mill type: -

Vertical boring mill is highly accurate but slower to operate.

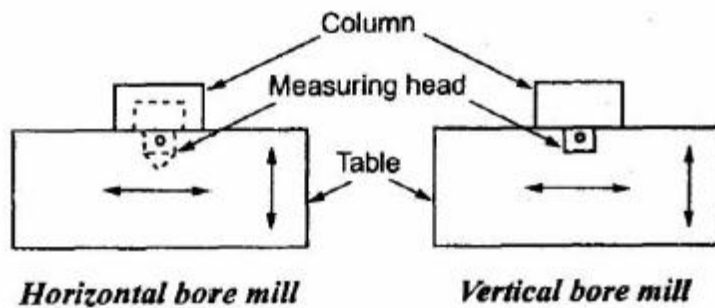
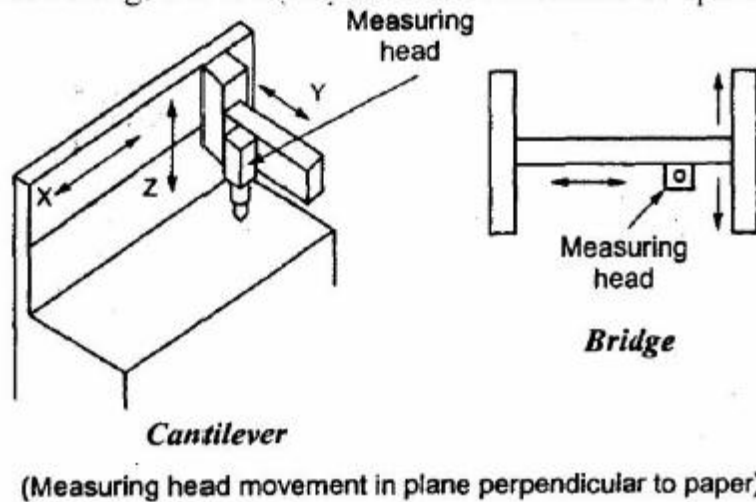

Fig 4.12 Types of CMM

Video Content / Details of website for further learning (if any):

Basic concept of CMM

Important Books/Journals for further learning including the page nos.:

Jain R.K, Engineering Metrology, Khanna Publishers, 2005 Page no: 792,808,1166

Course Faculty

Verified by HOD



MUTHAYAMMAL ENGINEERING COLLEGE

(An Autonomous Institution)

(Approved by AICTE, New Delhi, Accredited by NAAC & Affiliated to Anna University)

Rasipuram - 637 408, Namakkal Dist., Tamil Nadu



LECTURE HANDOUTS

L - 22

MECH

Year/Sem : III / VI

Course Name : Metrology and Measurements

Unit : III

Topic of Lecture: Constructional features – Probes – Accessories

Introduction :

A coordinate measuring machine (CMM) is a device that measures the geometry of physical objects by sensing discrete points on the surface of the object with a probe. Various types of probes are used in CMMs, including mechanical, optical, laser, and white light.

Prerequisite knowledge for Complete understanding and learning of Topic:

Types of CMM
Coordinates

Detailed content of the Lecture:

Coordinate-measuring machines include three main components:

- The main structure which includes three axes of motion. The material used to construct the moving frame has varied over the years. Granite and steel were used in the early CMM's. Today all the major CMM manufacturers build frames from aluminium alloy or some derivative and also use ceramic to increase the stiffness of the Z axis for scanning applications. Few CMM builders today still manufacture granite frame CMM due to market requirement for improved metrology dynamics and increasing trend to install CMM outside of the quality lab. Typically only low volume CMM builders and domestic manufacturers in China and India are still manufacturing granite CMM due to low technology approach and easy entry to become a CMM frame builder. The increasing trend towards scanning also requires the CMM Z axis to be stiffer and new materials have been introduced such as ceramic and silicon carbide.
- Probing system
- Data collection and reduction system – typically includes a machine controller, desktop computer and application software.

Machine body

In modern machines, the gantry-type superstructure has two legs and is often called a bridge. This moves freely along the granite table with one leg (often referred to as the inside leg) following a guide rail attached to one side of the granite table. The opposite leg (often outside leg) simply rests on the granite table following the vertical surface contour. Air bearings are the chosen method for ensuring friction free travel. In these, compressed air is forced through a series of very small holes in a flat bearing surface to provide a smooth but controlled air cushion on which the CMM can move in a frictionless manner. The movement of the bridge or gantry along the granite table forms one axis of the XY plane. The bridge of the gantry contains a carriage

which traverses between the inside and outside legs and forms the other X or Y horizontal axis. The third axis of movement (Z axis) is provided by the addition of a vertical quill or spindle which moves up and down through the center of the carriage. The touch probe forms the sensing device on the end of the quill. The movement of the X, Y and Z axes fully describes the measuring envelope. Optional rotary tables can be used to enhance the approachability of the measuring probe to complicated workpieces. The rotary table as a fourth drive axis does not enhance the measuring dimensions, which remain 3D, but it does provide a degree of flexibility. Some touch probes are themselves powered rotary devices with the probe tip able to swivel vertically through 90 degrees and through a full 360 degree rotation.

Mechanical probe

Measurements taken by this contact method were often unreliable as machines were moved by hand and each machine operator applied different amounts of pressure on the probe or adopted differing techniques for the measurement. A contact device, the probe had a spring-loaded steel ball (later ruby ball) stylus. As the probe touched the surface of the component the stylus deflected and simultaneously sent the X,Y,Z coordinate information to the computer. Measurement errors caused by individual operators became fewer and the stage was set for the introduction of CNC operations and the coming of age of CMMs.



Video Content / Details of website for further learning (if any):

<https://www.youtube.com/watch?v=AOrFen82WZk>

Important Books/Journals for further learning including the page nos.:

Jain R.K, Engineering Metrology, Khanna Publishers, 2005 Page no: 794

Course Faculty

Verified by HOD



MUTHAYAMMAL ENGINEERING COLLEGE

(An Autonomous Institution)

(Approved by AICTE, New Delhi, Accredited by NAAC & Affiliated to Anna University)

Rasipuram - 637 408, Namakkal Dist., Tamil Nadu



LECTURE HANDOUTS

L - 23

MECH

Year/Sem : III / VI

Course Name : Metrology and Measurements

Unit : III

Topic of Lecture: CMM Software

Introduction :

Software:

QUINDOS - Coordinate metrology software. QUINDOS is the ideal software for coordinate measuring machines, gear inspection centers and all applications.

Metrology software PC-DMIS. PC-DMIS® is the world's leading metrology software.

PolyWorks® Metrology Software.

Prerequisite knowledge for Complete understanding and learning of Topic:

Basic CMM

Types of CMM

Detailed content of the Lecture:

Features of CMM Software

(i) Measurement of diameter, center distance, length.

(ii) Measurement of plane and spatial carvers.

(iii) Minimum CNC programme.

(iv) Data communications.

(v) Digital input and output command.

(vi) Programme for the measurement of spur, helical, bevel' and hypoid gears.

(vii) Interface to CAD software.

A new software for reverse engineering complex shaped objects. The component is digitized using CNC CMM. The digitized data is converted into a computer model which is the true surface of the component. Recent advances include the automatic work part alignment and to orient the coordinate system. Savings in inspection time by using CMM is 5 to 10% compared to manual inspection method.

The main features of CNC-CMM are shown in figure has stationary granite measuring table, Length measuring system. Air bearings; control unit and software are the important parts of CNC & CMM. Robots can be used to carry out inspection or testing operation for mechanical dimension physical characteristics and product performance. Checking robot, programmable robot, and co-ordinate robot are some of the types given to a multi axis measuring machines. These machines automatically perform all the basic routines of a CNC co ordinate measuring machine but at a faster rate than that of CMM. They are not as accurate as p as CMM but they can check up to accuracies of 5micrometers. The co- ordinate robot can take successive readings at high speed and evaluate the results using a

computer graphics based real time statistical analysis system.

Integration of CAD/CAM with Inspection System

A product is designed, manufactured and inspected in one automatic process. One of the critical factors is in manufacturing equality assurance. The co-ordinate measuring machine assists in the equality assurance function. The productivity can be improved by interfacing with CAD/CAM system. This eliminates the labour, reduces preparation time and increases availability of CMM for inspection. Generally the CAD/CAM-CMM interface consists of a number of modules as given

(1) CMM interface

This interface allows to interact with the CAD/CAM database to generate a source file that can be converted to a CMM control data file. During source file creation, CMM probe path motions are simulated and displayed on the CAD/CAM workstation for visual verification. A set of CMM command allow the CMM interface to take advantage of most of the CMM functional capabilities.

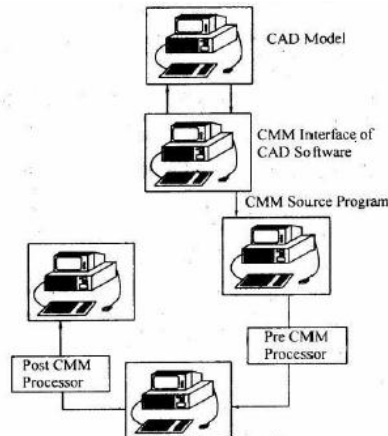

(2) Pre- processor

The pre-CMM processor converts the language source file generated by CMM interface into the language of the specified co ordinate measuring machine.

(3) Post-CMM processor

This creates wire frame surface model from the CMM-ASCII output file commands are inserted into the ASCII-CMM output file to control the creation of CAD/CAM which include points, lines, arcs, circles, conics, splines and analytic surfaces.

Video Content / Details of website for further learning (if any):

<https://www.youtube.com/watch?v=lZaWx8-oetQ>

Important Books/Journals for further learning including the page nos.:

Jain R.K, Engineering Metrology, Khanna Publishers, 2005 Page no: 797

Course Faculty

Verified by HOD



MUTHAYAMMAL ENGINEERING COLLEGE

(An Autonomous Institution)

(Approved by AICTE, New Delhi, Accredited by NAAC & Affiliated to Anna University)

Rasipuram - 637 408, Namakkal Dist., Tamil Nadu



LECTURE HANDOUTS

L - 24

MECH

Year/Sem : III / VI

Course Name : Metrology and Measurements

Unit : III

Topic of Lecture: Applications of CMM

Introduction :

Co-ordinate measuring machines find applications in automobile, machine tool, electronics, space and many other large companies.

Prerequisite knowledge for Complete understanding and learning of Topic:

Basic of CMM

Coordinate Systems

Dimensional Accuracy

Detailed content of the Lecture:

- These machines are best suited for the test and inspection of test equipment, gauges and tools.
- For aircraft and space vehicles, hundred percent inspections is carried out by using CMM.
- CMM can be used for determining dimensional accuracy of the components.

These are ideal for determination of shape and position, maximum metal condition, linkage of results etc. which cannot do in conventional machines.

- CMM can also be used for sorting tasks to achieve optimum pairing of components within tolerance limits.
- CMMs are also best for ensuring economic viability of NC machines by reducing their downtime for inspection results. They also help in reducing cost, rework cost at the appropriate time with a suitable CMM.

Advantages

- The inspection rate is increased.
- Accuracy is more.
- Operators error can be minimized.
- Skill requirements of the operator is reduced.
- Reduced inspection fixturing and maintenance cost.
- Reduction in calculating and recording time.

- Reduction in set up time.
- No need of separate go / no go gauges for each feature.
- Reduction of scrap and good part rejection.
- Reduction in off line analysis time.
- Simplification of inspection procedures, possibility
 - CMM can be used for the determining the determination the dimensional accuracy of the components.
 - CMM can also be used for the several single purpose of the equipments, gauges and the tools.

Video Content / Details of website for further learning (if any):

<https://www.youtube.com/watch?v=844UiRBVxLY>

Important Books/Journals for further learning including the page nos.:

Jain R.K, Engineering Metrology, Khanna Publishers, 2005 Page no: 799

Course Faculty

Verified by HOD



MUTHAYAMMAL ENGINEERING COLLEGE

(An Autonomous Institution)

(Approved by AICTE, New Delhi, Accredited by NAAC & Affiliated to Anna University)

Rasipuram - 637 408, Namakkal Dist., Tamil Nadu



LECTURE HANDOUTS

L - 25

MECH

Year/Sem : III / VI

Course Name : Metrology and Measurements

Unit : III

Topic of Lecture: Basic concepts of Machine Vision System

Introduction :

Machine Vision

A Vision system can be defined as a system for automatic acquisition and analysis of images to obtain desired data for interpreting or controlling an activity. It is technique which allows a sensor to view a scene and derive a numerical or logical decision without further human intervention. Machine vision can be defined as a means of simulating the image recognition and analysis capabilities of the human system with electronic and electro mechanical techniques. Machine vision system are now a days used to provide accurate and in expensive 100% inspection of work pieces.

Prerequisite knowledge for Complete understanding and learning of Topic:

Image Capturing

Image Interpretation

Detailed content of the Lecture:

Vision System

The schematic diagram of a typical vision system is shown. This system involves image acquisition; image processing Acquisition requires appropriate lighting. The camera and store digital image processing involves manipulating the digital image to simplify and reduce number of data points. Measurements can be carried out at any angle along the three reference axes x y and z without contacting the part. The measured values are then compared with the specified tolerance which stores in the memory of the computer.

Principle

Four types of machine vision system and the schematic arrangement is shown

- (i) Image formation.
- (ii) Processing of image in a form suitable for analysis by computer.
- (iii) Defining and analyzing the characteristic of image.
- (iv) Interpretation of image and decision-making.

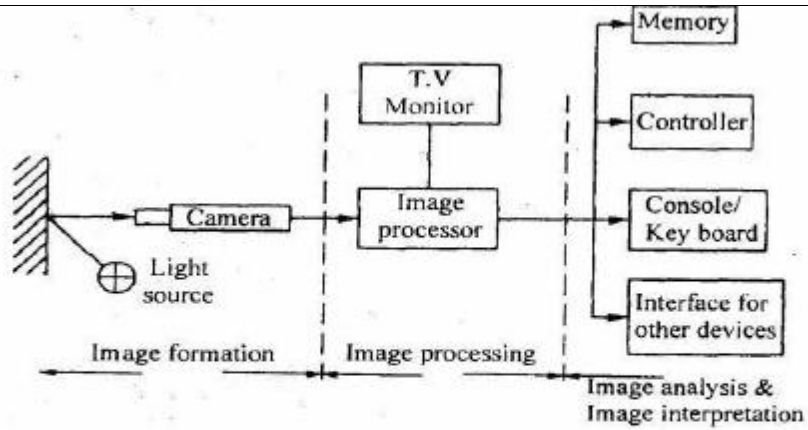
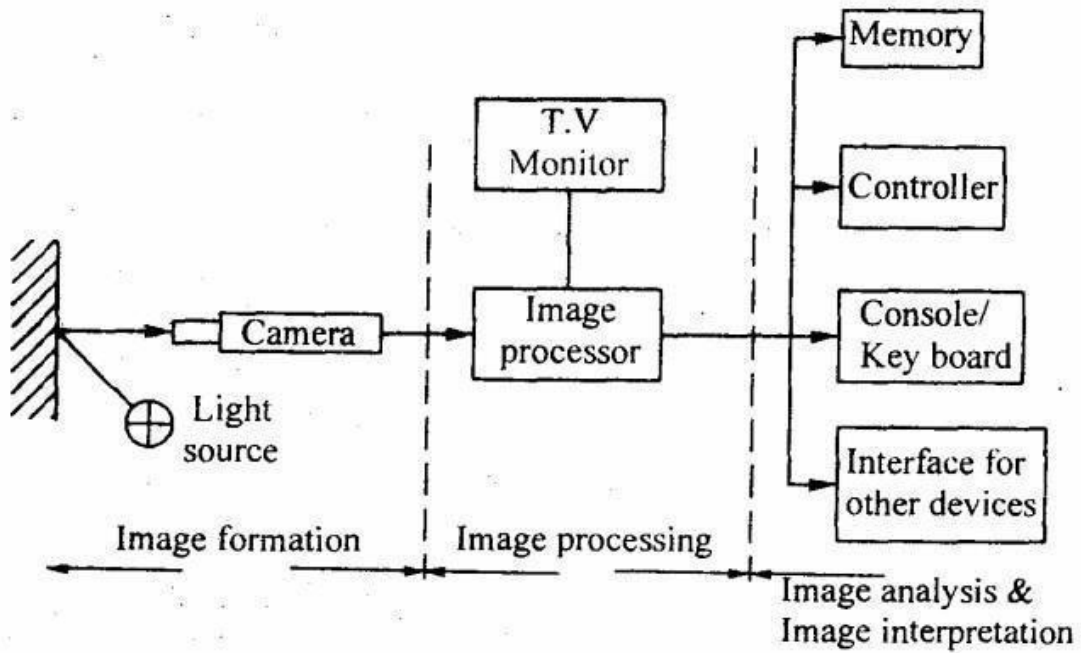

Fig 4.23 Schematic arrangement of Machine Vision



Video Content / Details of website for further learning (if any):

<https://www.youtube.com/watch?v=qq6--4jtj7s>

Important Books/Journals for further learning including the page nos.:

Jain R.K, Engineering Metrology, Khanna Publishers, 2005 Page no: 818

Course Faculty

Verified by HOD



MUTHAYAMMAL ENGINEERING COLLEGE

(An Autonomous Institution)

(Approved by AICTE, New Delhi, Accredited by NAAC & Affiliated to Anna University)

Rasipuram - 637 408, Namakkal Dist., Tamil Nadu



LECTURE HANDOUTS

L - 26

MECH

Year/Sem : III / VI

Course Name : Metrology and Measurements

Unit : III

Topic of Lecture: Element of Machine Vision System

Introduction :

A machine vision system (MVS) is a type of technology that enables a computing device to inspect, evaluate and identify still or moving images. It is a field in computer vision and is quite similar to surveillance cameras, but provides automatic image capturing, evaluation and processing capabilities

Prerequisite knowledge for Complete understanding and learning of Topic:

Image Processing

Inspection

Detailed content of the Lecture:

Four types of machine vision system and the schematic arrangement is shown

(i) Image formation.

(ii) Processing of image in a form suitable for analysis by computer.

(iii) Defining and analyzing the characteristic of image.

(iv) Interpretation of image and decision-making.

Microprocessor based gauges and other inspection devices. The terminal provides interactive communication with personal computers where the programmes are stored. The data from CMMs and other terminals are fed into the main computer for analysis and feedback control. The equality control data and inspection data from each station are fed through the terminals to the main computer. The data will be communicated through telephone lines. Flexible inspection system involves more than one inspection station. The objective of the flexible inspection system is to have off time multi station automated dimensional verification system to increase the production rate and less inspection time and to maintain the inspection accuracy and data processing integrity.

For formation of image suitable light source is required. It consists of incandescent light, fluorescent tube, fiber optic bundle, and arc lamp. Laser beam is used for triangulation system for measuring distance. Ultraviolet light is used to reduce glare or increase contrast. Proper illumination back lighting, front lighting, structured light is required. Back lighting is used to obtain maximum image contrast. The surface of the object is to be inspected by using front lighting. For inspecting three-dimensional feature structured lighting is required. An image sensor vidicon camera, CCD camera is used to generate the electronic signal representing the image. The image sensor collects light from the scene through a lens, using photosensitive target, converts into electronic signal.

Image formation:

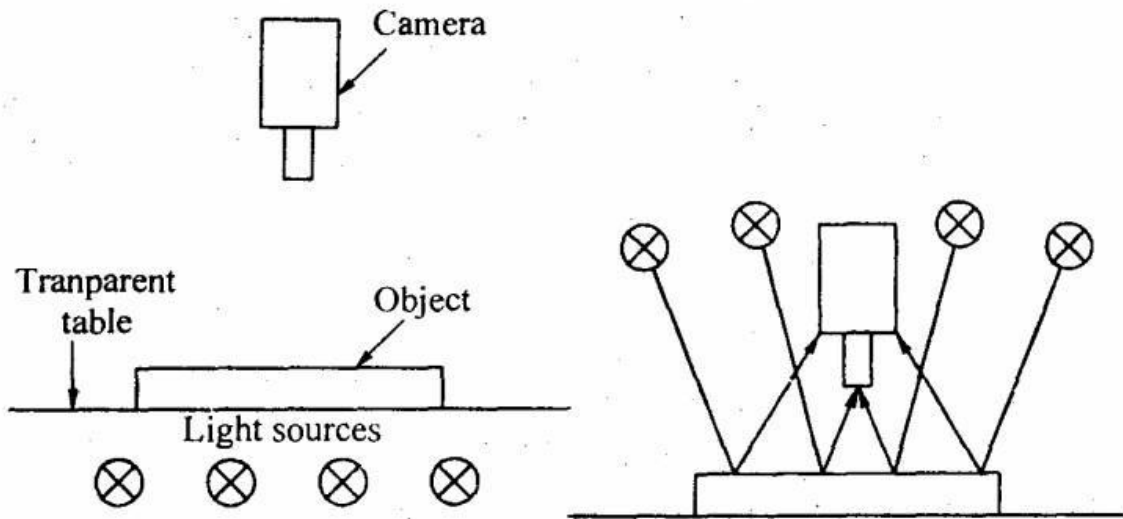

For formation of image suitable light source is required. It consists of incandescent light, fluorescent tube, fiber optic bundle, and arc lamp. Laser beam is used for triangulation system for measuring distance. Ultraviolet light is used to reduce glare or increase contrast. Proper illumination back lighting, front lighting, structured light is required. Back lighting is used to obtain maximum image contrast. The surface of the object is to be inspected by using front lighting. For inspecting three-dimensional feature structured lighting is required. An image sensor vidicon camera, CCD camera is used to generate the electronic signal representing the image. The image sensor collects light from the scene through a lens, using photosensitive target, converts into electronic signal.

A camera may form an image 30 times per sec at 33 m sec intervals. At each time interval the entire image frozen by an image processor for processing. An analog to digital converter is used to convert analog voltage of each detector in to digital value. If voltage level for each pixel is given by either 0 or 1 depending on threshold value. It is called binary system on the other hand grey scale system assigns upto 256 different values depending on intensity to each pixel. Grey scale system requires higher degree of image refinement, huge storage processing capability.

Video Content / Details of website for further learning (if any):

<https://www.youtube.com/watch?v=iXCfXCxpy1U>

Important Books/Journals for further learning including the page nos.:

Jain R.K, Engineering Metrology, Khanna Publishers, 2005 Page no: 1094

Course Faculty

Verified by HOD



MUTHAYAMMAL ENGINEERING COLLEGE

(An Autonomous Institution)

(Approved by AICTE, New Delhi, Accredited by NAAC & Affiliated to Anna University)

Rasipuram - 637 408, Namakkal Dist., Tamil Nadu



LECTURE HANDOUTS

L - 28

MECH

Year/Sem : III / VI

Course Name : Metrology and Measurements

Unit : IV

Topic of Lecture: Principles of Form Measurement

Introduction :

A form measurement is conducted to determine the overall shape of an object under test, which may refer to its flatness, straightness, parallelism, roundness, or cylindricity.

Prerequisite knowledge for Complete understanding and learning of Topic:

GD & T

Measuring Instruments

Detailed content of the Lecture:

INTRODUCTION

Threads are of prime importance, they are used as fasteners. It is a helical groove, used to transmit force and motion. In plain shaft, the hole assembly, the object of dimensional control is to ensure a certain consistency of fit. The performance of screw threads during their assembly with nut depends upon a number of parameters such as the condition of the machine tool used for screw cutting, work material and tool. Form measurement includes

- ☐ Screw thread measurement
- ☐ Gear measurement
- ☐ Radius measurement
- ☐ Surface Finish measurement
- ☐ Straightness measurement
- ☐ Flatness and roundness measurements

Screw Thread Measurement

Screw threads are used to transmit the power and motion, and also used to fasten two components with the help of nuts, bolts and studs. There is a large variety of screw threads varying in their form, by included angle, head angle, helix angle etc. The screw threads are mainly classified into 1) External thread 2) Internal thread.

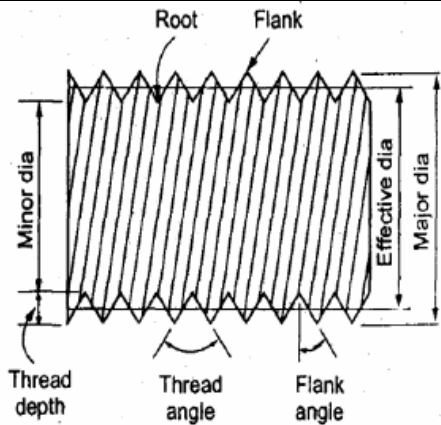

Fig 3.1 External Thread

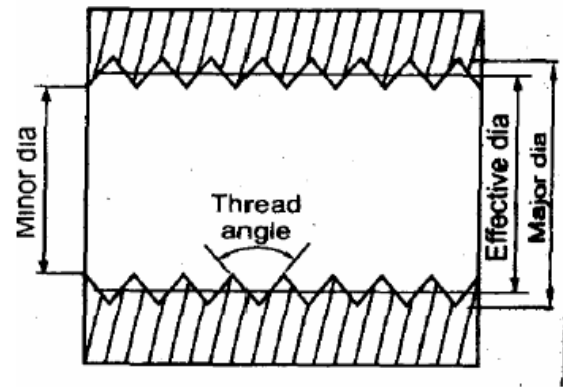
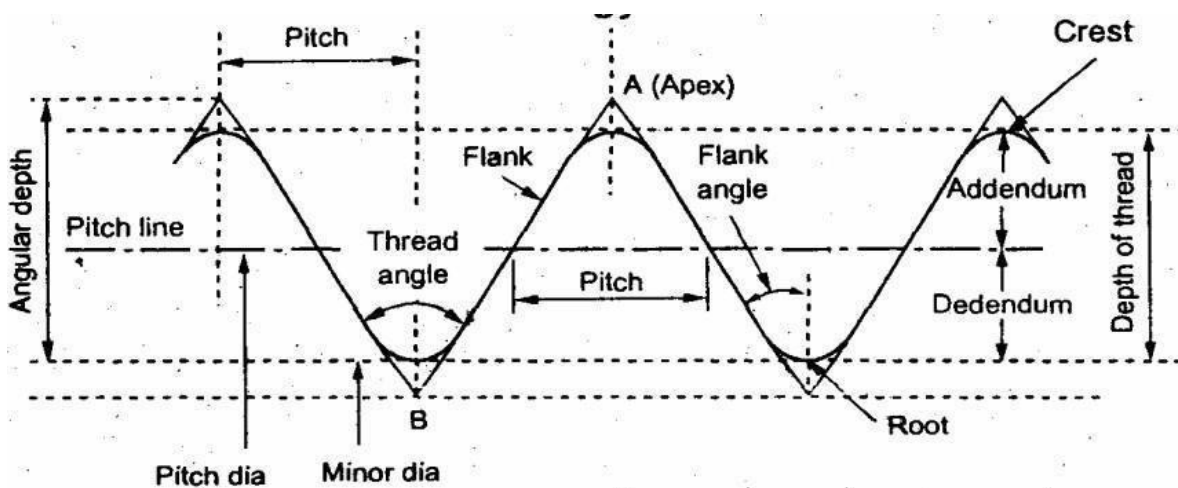

Fig 3.2 Internal Thread

Screw Thread Terminology



- **Minor diameter:**
It is the diameter of an imaginary co-axial cylinder which touches the roots of external threads.
- **Major diameter:**
It is the diameter of an imaginary co-axial cylinder which touches the crests of an external thread and the root of an internal thread.
- **Lead:**
The axial distance advanced by the screw in one revolution is the lead.
- **Pitch diameter:**
It is the diameter at which the thread space and width are equal to half of the screw thread
- **Helix angle:**
It is the angle made by the helix of the thread at the pitch line with the axis. The angle is measured in an axial plane
- **Flank angle:**
It is the angle between the flank and a line normal to the axis passing through the apex of the thread.
- **Height of thread:**
It is the distance measured radially between the major and minor diameters respectively
- **Addendum:**
Radial distance between the major and pitch cylinders for external thread.
Radial distance between the minor and pitch cylinder for internal thread.
- **Dedendum:**
It is the radial distance between the pitch and minor cylinders for external thread. Also radial distance between the major and pitch cylinders for internal thread.

Error in Thread

The errors in screw thread may arise during the manufacturing or storage of threads. The errors either may cause in following six main elements in the thread.

- 1) Major diameter error
- 2) Minor diameter error
- 3) Effective diameter error
- 4) Pitch error
- 5) Flank angles error
- 6) Crest and root error

1) Major diameter error

It may cause reduction in the flank contact and interference with the matching threads.

2) Minor diameter error

It may cause interference, reduction of flank contact.

3) Effective diameter error

If the effective diameter is small the threads will be thin on the external screw and thick on an internal screw.

4) Pitch errors

If error in pitch, the total length of thread engaged will be either too high or too small.

The various pitch errors classified into

1. Progressive error
2. Periodic error
3. Drunken error
4. Irregular error

Video Content / Details of website for further learning (if any):

<https://www.youtube.com/watch?v=CtGXjmqZqWc>

Important Books/Journals for further learning including the page nos.:

Jain R.K, Engineering Metrology, Khanna Publishers, 2005 Page no: 681

Course Faculty

Verified by HOD



MUTHAYAMMAL ENGINEERING COLLEGE

(An Autonomous Institution)

(Approved by AICTE, New Delhi, Accredited by NAAC & Affiliated to Anna University)

Rasipuram - 637 408, Namakkal Dist., Tamil Nadu



LECTURE HANDOUTS

L - 29

MECH

Year/Sem : III / VI

Course Name : Metrology and Measurements

Unit : IV

Topic of Lecture: Methods of straightness

Introduction :

Straightness is measured by observing the colour of light by diffraction while passing through the small gap. If the colour of light be red, it indicates a gap of 0.0012 to 0.0075mm.

Prerequisite knowledge for Complete understanding and learning of Topic:

Geometry
Tolerances

Detailed content of the Lecture:

Straightness actually has two very different functions in GD&T depending on how it is called out. In its normal form or Surface Straightness, is a tolerance that controls the form of a line somewhere on the surface or the feature. Axis Straightness is a tolerance that controls how much curve is allowed in the part's axis. This is usually called out with an included call to maximum material condition. Both callouts are very different from each other

Surface Straightness:

The standard form of straightness is a 2-Dimensional tolerance that is used to ensure that a part is uniform across a surface or feature. Straightness can apply to either a flat feature such as the surface of a block, or it can apply to the surface of a cylinder along the axial direction. It is defined as the variance of the surface within a specified line on that surface.

Axis Straightness:

The form of straightness that controls the central axis of a part is sometimes referred to as Axial Straightness. This tolerance callout specifies how straight the axis of a part is (usually a cylinder). By definition, axis straightness is actually a 3D tolerance that constrains the center axis of the part preventing it from bending or twisting too far.

Maximum Material Condition further specifies this by controlling the size of the feature in addition to the allowed "bend" of the axis. Although a control of the axis, when MMC is called out, the entire part is used to determine if the tolerance has been met with a Go-Gauge.

Gauging / Measurement:

Surface:

A part is constrained and a gauge measures along a straight line. In this example, the height variance is measured to see how flat or straight the line is along this surface.

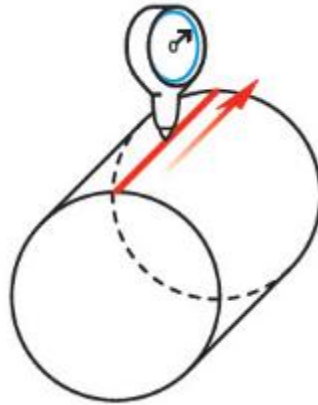

Axis:

To gauge axis straightness effectively, MMC is commonly called out. To ensure that a part or feature is axially straight, a cylinder gauge is used to determine if the part fits in its total envelope at MMC. This is both a control of the diameter and of the axial straightness. The ID of the cylinder gauge represents the maximum virtual condition of the part.

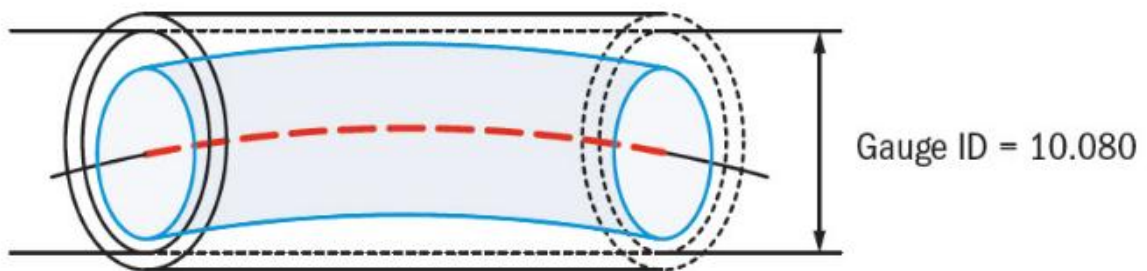

Video Content / Details of website for further learning (if any):

https://www.youtube.com/watch?v=gJ5pDgO-D_M

Important Books/Journals for further learning including the page nos.:

Jain R.K, Engineering Metrology, Khanna Publishers, 2005 Page no: 395, 764

Course Faculty

Verified by HOD



MUTHAYAMMAL ENGINEERING COLLEGE

(An Autonomous Institution)

(Approved by AICTE, New Delhi, Accredited by NAAC & Affiliated to Anna University)

Rasipuram - 637 408, Namakkal Dist., Tamil Nadu



LECTURE HANDOUTS

L - 30

MECH

Year/Sem : III / VI

Course Name : Metrology and Measurements

Unit : IV

Topic of Lecture: Flatness measurement

Introduction :

Flatness is can be measured using a height gauge run across the surface of the part if only the reference feature is held parallel. You are trying making sure that any point along the surface does not go above or below the tolerance zone.

Prerequisite knowledge for Complete understanding and learning of Topic:

Tolerance
Geometrical Dimensioning

Detailed content of the Lecture:

FLATNESS TESTING

Flatness testing is possible by comparing the surface with an accurate surface. This method is suitable for small plates and not for large surfaces. Mathematically flatness error of a surface states that the departure from flatness is the minimum separation of a pair of parallel planes which will contain all points on the Surface. The figure which shows that a surface can be considered to be composed of an infinitely large number of lines. The surface will be flat only if all the lines are straight and they lie in the same plane. In the case of rectangular table arc the lines are straight and parallel to the sides of the rectangle in both the perpendicular direction. Even it is not flat, but concave and convex along two diagonals. For verification, it is essential to measure the straightness of diagonals in addition to the lines parallel to the sides. in accuracy. The straightness of all these lines is determined and then those lines are related with each other in order to verify whether they lie in the same plane or not.

Procedure for determining flatness

The fig. shows the flatness testing procedure.

- (i) Carry out the straightness test and tabulate the reading up to the cumulative error column.
- (i) Ends of lines AB, AD and BD are corrected to zero and thus the height of the points A, B and D are zero.

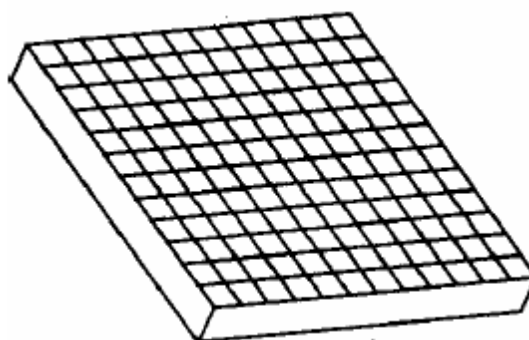

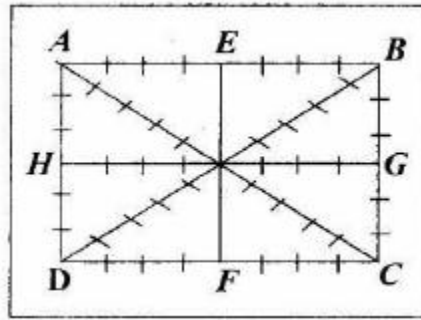

The height of the point I is determined relative to the arbitrary plane $ABD = 000$. Point C is now fixed relative to the arbitrary plane and points B and D are set at zero, all intermediate points on BC and DC can be corrected accordingly. The positions of H and G, E and F are known, so it is now possible to fit in lines HG and EF. This also provides a check on previous evaluations since the mid-point of these lines should coincide with the position of mid-point I. In this way, the height of all the points on the surface relative to the arbitrary plane ABD is known.

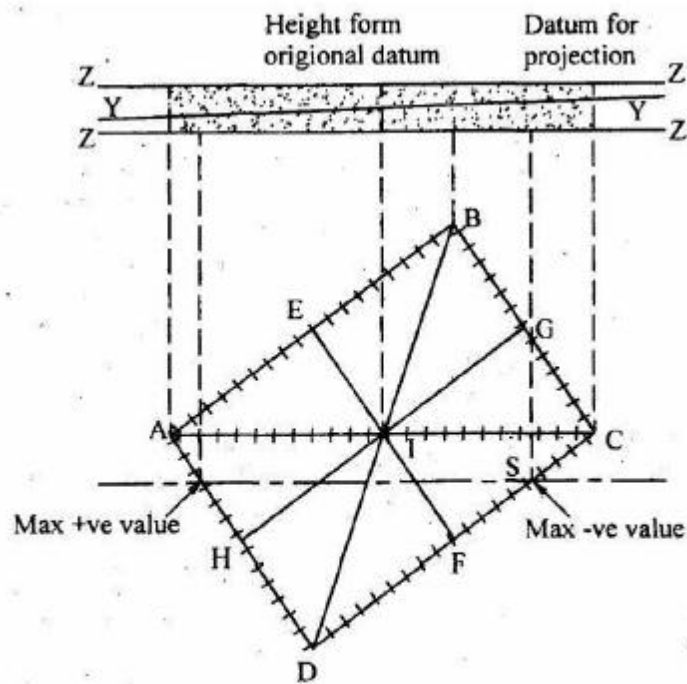

Fig 3.29 Flatness Testing

Video Content / Details of website for further learning (if any):

<https://www.youtube.com/watch?v=80sNyYPTXPA>

Important Books/Journals for further learning including the page nos.:

Jain R.K, Engineering Metrology, Khanna Publishers, 2005 Page no: 421

Course Faculty

Verified by HOD



MUTHAYAMMAL ENGINEERING COLLEGE

(An Autonomous Institution)

(Approved by AICTE, New Delhi, Accredited by NAAC & Affiliated to Anna University)

Rasipuram - 637 408, Namakkal Dist., Tamil Nadu



LECTURE HANDOUTS

L - 31

MECH

Year/Sem : III / VI

Course Name : Metrology and Measurements

Unit : IV

Topic of Lecture: Thread measurement

Introduction :

The screw thread micrometer is designed to measure the pitch diameter of screw threads up to 0.01mm of accuracy. (ii) The end of the anvil is the same as the screws thread to be measured. The reading is read in similar way as in case of outside micrometer.

Prerequisite knowledge for Complete understanding and learning of Topic:

Screw Terminology
Accuracy and Precision

Detailed content of the Lecture:

Measurement of various elements of Thread

To find out the accuracy of a screw thread it will be necessary to measure the following:

1. Major diameter.
2. Minor diameter.
3. Effective or Pitch diameter.
4. Pitch
5. Thread angle and form

1. Measurement of major diameter:

The instruments which are used to find the major diameter are by

- Ordinary micrometer
- Bench micrometer.

Ordinary micrometer

The ordinary micrometer is quite suitable for measuring the external major diameter. It is first adjusted for appropriate cylindrical size (S) having the same diameter (approximately). This process is known as 'gauge setting'. After taking this reading 'R' the micrometer is set on the major diameter of the thread, and the new reading is 'R2'.

- Bench micrometer**

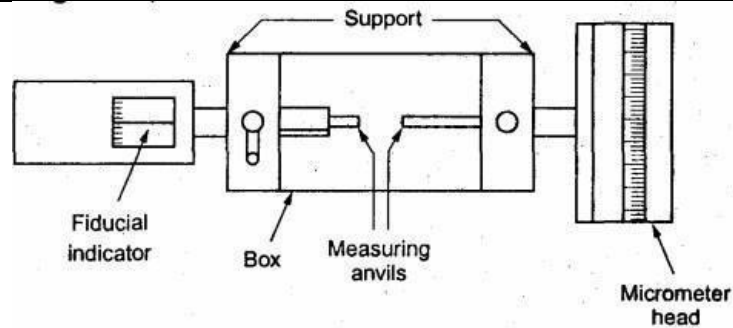

For getting the greater accuracy the bench micrometer is used for measuring the major diameter. In this process the variation in measuring Pressure, pitch errors are being neglected. The instrument has a micrometer head with a vernier scale to read the accuracy of 0.002mm. Calibrated setting cylinder having the same diameter as the major diameter of the thread to be measured is used as setting standard. After setting the standard, the setting cylinder is held between the anvils and the reading is taken. Then the cylinder is replaced by the threaded work piece and the new reading is taken.

∴ The major diameter of screw thread

$$= S \pm (D_2 - D_1)$$

Where, S = Diameter of the setting cylinder.

R_2 = Micrometer Reading on screw thread

R_1 = Micrometer reading on setting cylinder.

2. Measurement of Minor diameter

The minor diameter is measured by a comparative method by using floating carriage diameter measuring machine and small V pieces which make contact with the root of the thread. These V pieces are made in several sizes, having suitable radii at the edges. V pieces are made of hardened steel. The floating carriage diameter-measuring machine is a bench micrometer mounted on a carriage.

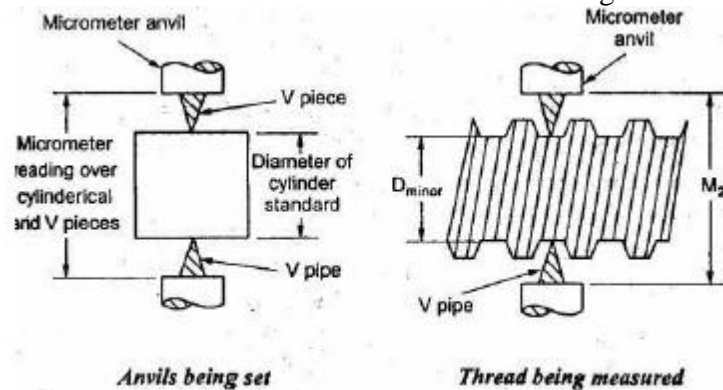

• Measurement process

The threaded work piece is mounted between the centers of the instrument and the V pieces are placed on each side of the work piece and then the reading is noted. After taking this reading the work piece is then replaced by a standard reference cylindrical setting gauge.

$$\text{The minor diameter of the thread} = D \pm (R_2 - R_1)$$

Where, D = Diameter of cylindrical gauge

R_2 = Micrometer reading on threaded work piece.

R_1 = Micrometer reading on cylindrical gauge.

3. Measurement of effective diameter

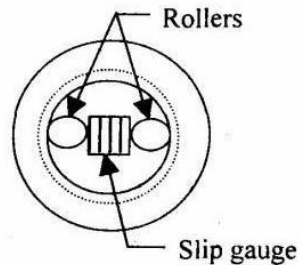

Fig 3.9 Roller gauge

Effective diameter measurement is carried out by following methods.

1. One wire,
2. Two wires, or
3. Three wires method.
4. Micrometer method.

a) One wire method

The only one wire is used in this method. The wire is placed between two threads at one side and on the other side the anvil of the measuring micrometer contacts the crests. First the micrometer reading d_1 is noted on a standard gauge whose dimension is approximately same to be obtained by this method.

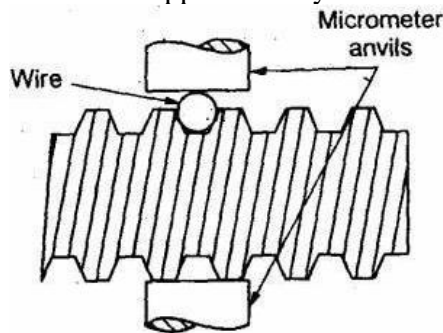

i.e. ' d_2 ' then effective diameter = $D \pm (d_1 - d_2)$

When D = Size of setting gauge

Actual measurement over wire on one side and threads on other

Video Content / Details of website for further learning (if any):

<https://www.youtube.com/watch?v=Gdvtw0pTAOs>

Important Books/Journals for further learning including the page nos.:

Jain R.K, Engineering Metrology, Khanna Publishers, 2005 Page no: 687

Course Faculty

Verified by HOD

LECTURE HANDOUTS

L - 32

MECH

Year/Sem : III / VI

Course Name : Metrology and Measurements

Unit : IV

Topic of Lecture: Floating Carriage Micrometer

Introduction :

Floating carriage micrometer is also a micrometer used to measure the major diameter, minor diameter and the effective diameter of a threaded surface. This micrometer having a main scale, thimble scale and an anvil and also a pressure gauge is attached to measure the applying pressure. The least count of the floating carriage micrometer is 0.002mm.

Prerequisite knowledge for Complete understanding and learning of Topic:

Thread Terminology
Accuracy

Detailed content of the Lecture:

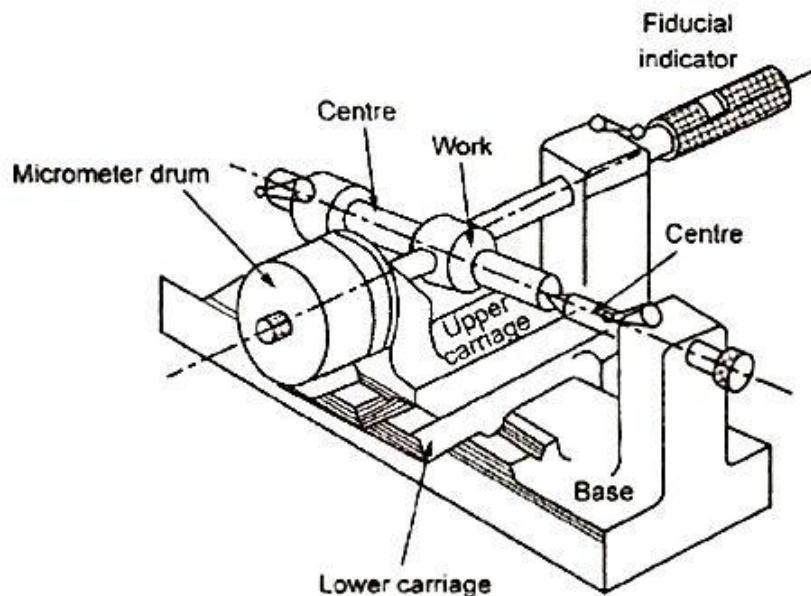

1. First the indicator of the pressure gauge is set to zero by using initial adjustment then the specimen is placed between two centres, the standard dimensions in the corresponding values are noted.
2. Then the plug gauge is placed in the two centers for measuring the effective, major and minor diameter.
3. Simultaneously the thread work piece is first measured by placing between the two centers.
4. By placing the prism plug gauge, the readings are noted. By using the formula, we can calculate the R_w of the work piece.

FORMULA:

Major diameter

$$max = D + (Rs - Rw) \quad , \quad min = D - (Rs - Rw)$$

Minor diameter

$$max = D + (Rs - Rw) \quad , \quad min = D - (Rs - Rw)$$

Effective diameter

$$max = D + (Rs - P) - Rw \quad , \quad min = D - (Rs - p) - Rw$$

Video Content / Details of website for further learning (if any):<https://www.youtube.com/watch?v=PBD9FpWtdPo>**Important Books/Journals for further learning including the page nos.:**

Jain R.K, Engineering Metrology, Khanna Publishers, 2005 Page no: 692

Course Faculty**Verified by HOD**

LECTURE HANDOUTS

L - 33

MECH

Year/Sem : III / VI

Course Name : Metrology and Measurements

Unit : IV

Topic of Lecture: Pitch Measurement – Tool Maker’s Microscope

Introduction :

Tool Maker’s Microscope is a precision Optical Microscope that consists of single or multiple objective lenses, which magnifies the object under observation and by the help of eyepiece lens the object is focused and viewed. A high precision micrometric X-Y stage and the Z axis travel are used to measure the three dimensions [Length (X), Width (Y), Depth (Z)]. The angle is measured with the help of a rotating stage and eyepiece graduation.

Prerequisite knowledge for Complete understanding and learning of Topic:

Thread Measurement
Thread - Terminology

Detailed content of the Lecture:

Pitch measurement

The most commonly used methods for measuring the pitch are

1. Tool maker’s microscope
2. Screw pitch gauge

Tool makers microscope

Working

Worktable is placed on the base of the base of the instrument. The optical head is mounted on a vertical column it can be moved up and down. Work piece is mounted on a glass plate. Image of the outline contour of the work piece passes through the objective of the optical head. The image is projected by a system of three prisms to a ground glass screen.

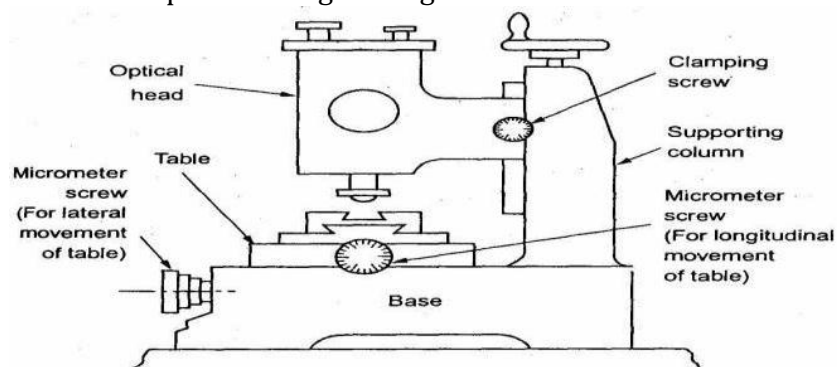

Procedure:

Switch on the projection lamp. Get familiar with the least count, linear and angular readings of the tool maker's microscope and nomenclature of the thread shown in Fig.2. Place the given specimen (thread gauge shown in Fig.3) on the glass table plate. Viewing through the eyepiece, rotate the knob for moving carrier arm on column to get the sharp image of the specimen kept on the glass plate. Position the specimen such that the table movement in the X direction is parallel to the direction of the pitch measurement. This is checked by ensuring the crosswire touching the tips (crests) of all the teeth during table movement in the X direction.

- To measure the pitch: Rotate micrometer head for X direction to touch the intersection point of the crosswire to the crest of the thread as seen from the eye piece. Note down the reading of the micrometer. Again rotate the micrometer head to move the specimen so that the next successive crest will come in contact with the crosswire intersection point. Note down the reading. The difference in reading will give the pitch.

- To measure the depth of the thread: Similarly rotate micrometer head for Y direction to touch the intersection point of the crosswire (along with the horizontal dotted line) to the root of the thread, as seen from the eye piece. Note down the reading of the micrometer. Again rotate the micrometer head to move the specimen so that the horizontal dotted line touches all the crests. Note down the reading. The difference in reading will give the depth of the thread.

- To measure the thread angle: Rotate the crosswire by the silver colour knob located behind the eye piece to match the flank of the thread with the cross wire. Make use of both the micrometer heads for X and Y direction to move the flank, and note down the angle by viewing through the lens below the eye piece. Now rotate only the crosswire to match the opposite flank and note down the angle. The difference will give the thread angle.

Applications

- Linear measurements.
- Measurement of pitch of the screw.
- Measurement of pitch diameter.
- Measurement of thread angle.
- Comparing thread forms.
- Centre to center distance measurement.
- Thread form and flank angle measurement

□ Thread form and flank angle measurement

The optical projections are used to check the thread form and angles in the thread. The projectors equipped with work holding fixtures, lamp, and lenses. The light rays from the lens are directed into the cabinet and prisms and mirrors.

Video Content / Details of website for further learning (if any):

<https://www.youtube.com/watch?v=BdKiYrwCyV0>

Important Books/Journals for further learning including the page nos.:

Jain R.K, Engineering Metrology, Khanna Publishers, 2005 Page no: 787

Course Faculty

Verified by HOD



MUTHAYAMMAL ENGINEERING COLLEGE

(An Autonomous Institution)

(Approved by AICTE, New Delhi, Accredited by NAAC & Affiliated to Anna University)

Rasipuram - 637 408, Namakkal Dist., Tamil Nadu



LECTURE HANDOUTS

L - 34

MECH

Year/Sem : III / VI

Course Name : Metrology and Measurements

Unit : IV

Topic of Lecture: Gear measurement

Introduction :

The following topics gear tooth measurement by gear tooth vernier caliper, constant chord method, base tangent method, pitch measurement, gear tooth involute form inspection are discussed in this lecture.

Prerequisite knowledge for Complete understanding and learning of Topic:

Gear Terminology

Gear Production

Indexing

Detailed content of the Lecture:

GEAR MEASUREMENT

Introduction

Gear is a mechanical drive which transmits power through toothed wheel. In this gear drive, the driving wheel is in direct contact with driven wheel..

The most commonly used forms of gear teeth are

1. Involute

2. Cycloidal

The involute gears also called as straight tooth or spur gears. The cycloidal gears are used in heavy and impact loads. The involute rack has straight teeth. The involute pressure angle is either 20° or 14.5° .

Types of gears

1. Spur gear

Cylindrical gear whose tooth traces is straight line. These are used for transmitting power between parallel shafts.

2. Spiral gear

The tooth of the gear traces curved lines.

3. Helical gears

These gears used to transmit the power between parallel shafts as well as nonparallel and non-intersecting shafts. It is a cylindrical gear whose tooth traces is straight line.

4. Bevel gears:

The tooth traces are straight-line generators of cone. The teeth are cut on the conical surface. It is used to connect the shafts at right angles.

5. Worm and Worm wheel:

It is used to connect the shafts whose axes are non-parallel and non-intersecting.

6. Rack and Pinion:

Rack gears are straight spur gears with infinite radius.

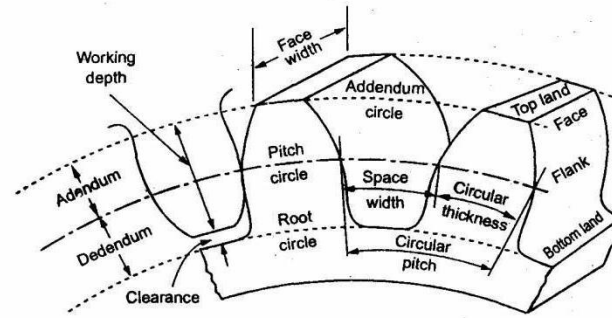

Gear Measurement

The Inspection of the gears consists of determine the following elements in which manufacturing error may be present.

1. Runout.
2. Pitch
3. Profile
4. Lead
5. Back lash
6. Tooth thickness
7. Concentricity
8. Alignment

1. Runout:

It means eccentricity in the pitch circle. It will give periodic vibration during each revolution of the gear. This will give the tooth failure in gears. The run out is measured by means of eccentricity testers. In the testing the gears are placed in the mandrel and the dial indicator of the tester possesses special tip depending upon the module of the gear and the tips inserted between the tooth spaces and the gears are rotated tooth by tooth and the variation is noted from the dial indicator.

2. Pitch measurement:

There are two ways for measuring the pitch.

1. Point to point measurement (i.e. One tooth point to next tooth point)
2. Direct angular measurement

1. Tooth to Tooth measurement

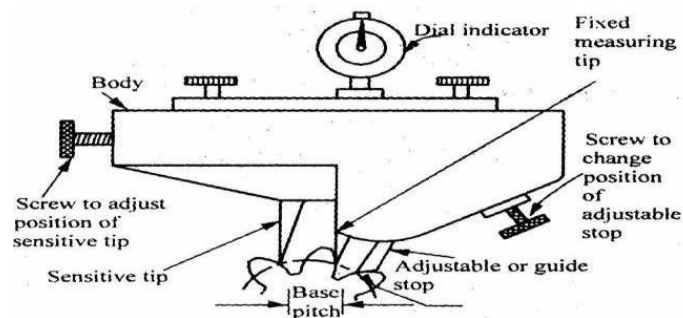

The sensitive tip, whose position can be adjusted by a screw and the third tip is adjustable or guide stop. All the three tips are contact the tooth by setting the instrument and the reading on the dial indicator is the error in the base pitch.

2. Direct Angular Measurement

It is the simplest method for measuring the error by using set dial gauge against a tooth. in this method the position of a suitable point on a tooth is measured after the gear has been indexed by a suitable angle.

Profile checking

The methods used for profile checking is

1. Optical projection method.
2. Involute measuring machine.

1. Optical projection method:

The profile of the gear projected on the screen by optical lens and then projected value is compared with master profile.

2. Involute measuring machine:

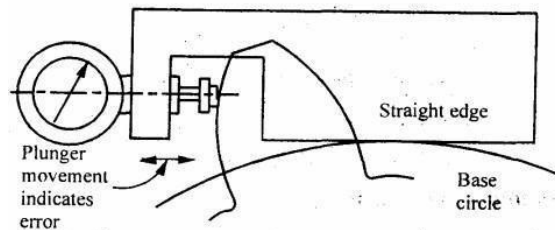

In this method the gear is held on a mandrel and circular disc of same diameter as the base circle of gear for the measurement is fixed on the mandrel. After fixing the gear in the mandrel, the straight edge of the instrument is brought in contact with the base circle of the disc. Now, the gear and disc are rotated and the edge moves over the disc without slip. The stylus moves over the tooth profile and the error is indicated on the dial gauge.

Parkinson Gear Tester Working principle

The master gear is fixed on vertical spindle and the gear to be tested is fixed on similar spindle which is mounted on a carriage. The carriage which can slide either side of these gears are maintained in mesh by spring pressure. When the gears are rotated, the movement of sliding carriage is indicated by a dial indicator and these variations are measure of any irregularities. The variation is recorded in a recorder which is fitted in the form of a waxed circular chart. In the gears are fitted on the mandrels and are free to rotate without clearance and the left mandrel move along the table and the right mandrel move along the spring-loaded carriage.

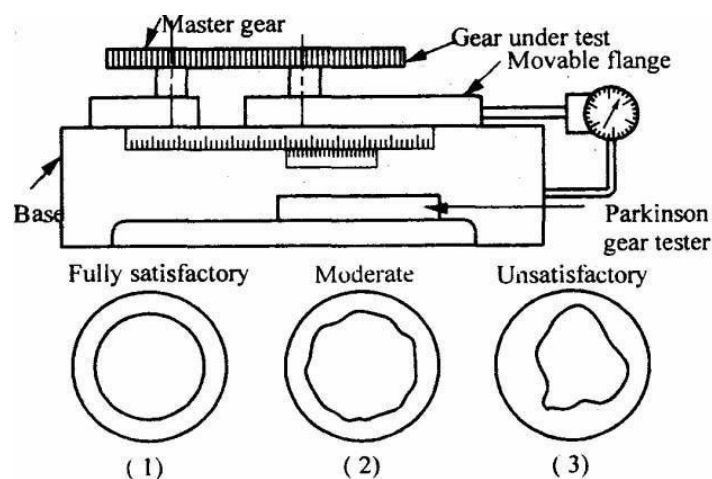

The two spindles can be adjusted so that the axial distance is equal and a scale is attached to one side and vernier to the other, this enables center distance to be measured to within 0.025mm. If any errors in the tooth form when gears are in close mesh, pitch or concentricity of pitch line will cause a variation in center distance from this movement of carriage as indicated to the dial gauge will show the errors in the gear test. The recorder also fitted in the form of circular or rectangular chart and the errors are recorded.

Video Content / Details of website for further learning (if any):

<https://www.youtube.com/watch?v=YtFAjaN8r7k>

Important Books/Journals for further learning including the page nos.:

Jain R.K, Engineering Metrology, Khanna Publishers, 2005 Page no: 739



MUTHAYAMMAL ENGINEERING COLLEGE

(An Autonomous Institution)

(Approved by AICTE, New Delhi, Accredited by NAAC & Affiliated to Anna University)

Rasipuram - 637 408, Namakkal Dist., Tamil Nadu



LECTURE HANDOUTS

L - 35

MECH

Year/Sem : III / VI

Course Name : Metrology and Measurements

Unit : IV

Topic of Lecture: Surface finish measurement

Introduction :

Topology of a surface, surface irregularities are superimposed on a widely spaced component of surface texture called waviness.

Prerequisite knowledge for Complete understanding and learning of Topic:

Roughing and Finishing operations
Accuracy and Precision

Detailed content of the Lecture:

Methods of measuring surface finish

The methods used for measuring the surface finish is classified into

1. Inspection by comparison
2. Direct Instrument Measurements

1. Inspection by comparison methods:

In these methods the surface texture is assessed by observation of the surface. The surface to be tested is compared with known value of roughness specimen and finished by similar machining process. The various methods which are used for comparison are

1. YYC Touch Inspection.
2. Visual Inspection.
3. Microscopic Inspection.
4. Scratch Inspection.
5. Micro Interferometer.
6. Surface photographs.
7. Reflected Light Intensity.
8. Wallace surface Dynamometer.

☒ **Touch Inspection**

It is used when surface roughness is very high and in this method the fingertip is moved along the surface at a speed of 25mm/second and the irregularities as up to 0.0125mm can be detected.

☒ **Visual Inspection**

In this method the surface is inspected by naked eye and this measurement is limited to rough surfaces.

Microscopic Inspection

In this method finished surface is placed under the microscopic and compared with the surface under inspection. The light beam also used to check the finished surface by projecting the light about 60° to the work.

Scratch Inspection:

The materials like lead, plastics rubbed on surface are inspected by this method. The impression of this scratches on the surface produced is then visualized.

Micro-Interferometer

Optical flat is placed on the surface to be inspected and illuminated by a monochromatic source of light.

Surface Photographs

Magnified photographs of the surface are taken with different types of illumination. The defects like irregularities are appear as dark spots and flat portion of the surface appears as bright.

Reflected light Intensity

A beam of light is projected on the surface to be inspected and the light intensity variation on the surface is measured by a photocell and this measured value is calibrated

2. Direct instrument measurements

Direct methods enable to determine a numerical value of the surface finish of any surface. These methods are quantitative analysis methods and the output is used to operate recording or indicating instrument. Direct Instruments are operated by electrical principles. These instruments are classified into two types according to the operating principle. In this is operated by carrier-modulating principle and the other is operated by voltage-generating principle, and in the both types the output is amplified.

Some of the direct measurement instruments are

1. Stylus probe instruments.

2. Tomlinson surface meter.

3. Profilometer.

4. Taylor-Hobson Talysurf

1. Stylus probe type instrument

Working

The stylus type instruments consist of skid, stylus, amplifying device and recording device. The skid is slowly moved over the surface by hand or by motor drive. The skid follows the irregularities of the surface and the stylus moves along with skid. When the stylus moves vertically up and down and the stylus movements are magnified, amplified and recorded to produce a trace. Then it is analyzed by automatic device.

2. Tomlinson Surface meter

This instrument uses mechanical-cum-optical means for magnification.

Construction

In this the diamond stylus on the surface finish recorder is held by spring pressure against the surface of a lapped cylinder. The lapped cylinder is supported one side by probe and other side by rollers. The stylus is also attached to the body of the instrument by a leaf spring and its height is adjustable to enable the diamond to be positioned and the light spring steel arm is attached to the lapped cylinder. The spring arm has a diamond scribe at the end and smoked glass is rest on the arm.

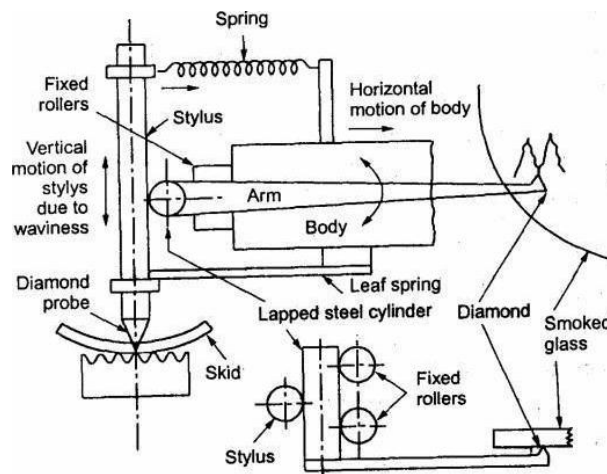

Working

When measuring surface finish the body of the instrument is moved across the surface by a screw rotation. The vertical movement of the probe caused by the surface irregularities makes the horizontal lapped cylinder to roll. This rolling of lapped cylinder causes the movement of the arm. So this movement induces the diamond scribe on smoked glass. Finally the movement of scribe together with horizontal movement produces a trace on the smoked glass plate and this trace is magnified by an optical projector.

3. Talyor-Hobson-Talysurf

It is working a carrier modulating principle and it is an accurate method comparing with the other methods. The main parts of this instrument is diamond stylus (0.002mm radius) and skid

Principle

The irregularities of the surface are traced by the stylus and the movement of the stylus is converted into changes in electric current.

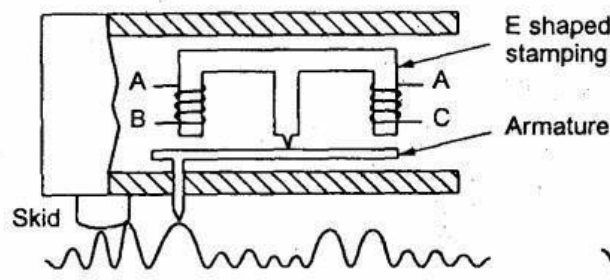

Working

On two legs of the E-shaped stamping there are coils for carrying an A.C. current and these coils form an oscillator. As the armature is pivoted about the central leg the movement of the stylus causes the air gap to vary and thus the amplitude is modulated. This modulation is again demodulated for the vertical displacement of the stylus. So this demodulated output is move the pen recorder to produce a numerical record and to make a direct numerical assessment.

Video Content / Details of website for further learning (if any):

https://www.youtube.com/watch?v=T-8I_-JkT4s

Important Books/Journals for further learning including the page nos.:

Jain R.K, Engineering Metrology, Khanna Publishers, 2005 Page no: 640, 662

Course Faculty

Verified by HOD



MUTHAYAMMAL ENGINEERING COLLEGE

(An Autonomous Institution)

(Approved by AICTE, New Delhi, Accredited by NAAC & Affiliated to Anna University)

Rasipuram - 637 408, Namakkal Dist., Tamil Nadu



LECTURE HANDOUTS

L - 36

MECH

Year/Sem : III / VI

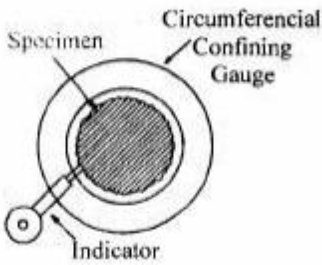
<p>Topic of Lecture: Roundness measurement</p>
<p>Introduction : Roundness is the measure of how closely the shape of an object approaches that of a mathematically perfect circle. Roundness applies in two dimensions, such as the cross sectional circles along a cylindrical object such as a shaft or a cylindrical roller for a bearing.</p>
<p>Prerequisite knowledge for Complete understanding and learning of Topic: Form Characteristics Accuracy</p>
<p>Detailed content of the Lecture:</p> <p>Roundness, or circularity, is the 2D tolerance that controls how closely a cross-section of a cylinder, sphere, or cone is to a mathematically perfect circle. Consider a cylinder whose purpose is to roll along a flat surface. A small flat on the OD of the cylinder would detract from how smoothly the shaft can roll. The flat spot can even be so large that the shaft cannot roll at all. In this case the flat represents a deviation from a perfect circle that can be measured quite accurately. An example of a more complex roundness error is called lobing, which is an unintended form error from a centerless grinding operation. Roundness callouts on drawings have no reference to a datum, as roundness does not relate to the cross-section's location on the part.</p> <p>Devices used for measurement of roundness</p> <ol style="list-style-type: none"> 1) Diametral gauge. 2) Circumferential conferring gauge => a shaft is confined in a ring gauge and rotated against a set indicator probe. 3) Rotating on center 4) V-Block <ol style="list-style-type: none"> 1. Diametric method: The measuring plungers are located 180° a part and the diameter is measured at several places. This method is suitable only when the specimen is elliptical or has an even number of lobes. Diametric check does not necessarily disclose effective size or roundness. This method is unreliable in determining roundness. 2. Circumferential confining gauge: Fig. shows the principle of this method. It is useful for inspection of roundness in production. This method requires highly accurate master for each size part to be measured. The clearance between part and gauge is critical to reliability. This technique does not allow for the measurement of other related geometric characteristics, such as concentricity, flatness of shoulders etc. <div style="text-align: center;">  </div> <ol style="list-style-type: none"> 3. Rotating on centers: The shaft is inspected for roundness while mounted on center. In this case, reliability is dependent on many factors like angle of centers, alignment of centres, roundness and surface condition of the centres and centre holes and run out of piece. Out of straightness of the part will cause a doubling run out effect and appear to be roundness error, 4. V-Block: The set up employed for assessing the circularity error by using V Block is shown in fig.

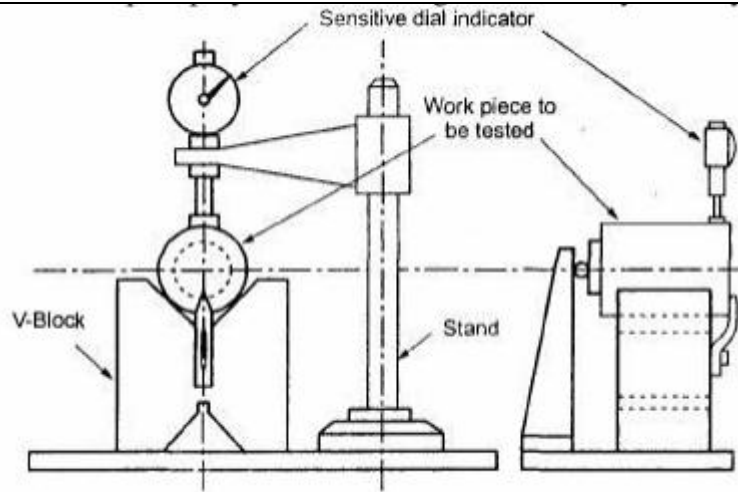

The V block is placed on surface plate and the work to be checked is placed upon it. A diameter indicator is fixed in a stand and its feeler made to rest against the surface of the work. The work is rotated to measure the rise on fall of the work piece. For determining the number of lobes on the work piece, the work piece is first tested in a 60° V-Block and then in a 90° V-Block. The number of lobes is then equal to the number of times the indicator pointer deflects through 360° rotation of the work piece.

Video Content / Details of website for further learning (if any):

https://www.youtube.com/watch?v=FqSJhY_ltc

Important Books/Journals for further learning including the page nos.:

Jain R.K, Engineering Metrology, Khanna Publishers, 2005 Page no: 499

Course Faculty

Verified by HOD



MUTHAYAMMAL ENGINEERING COLLEGE

(An Autonomous Institution)

(Approved by AICTE, New Delhi, Accredited by NAAC & Affiliated to Anna University)

Rasipuram - 637 408, Namakkal Dist., Tamil Nadu



LECTURE HANDOUTS

L - 37

MECH

Year/Sem : III / VI

Course Name : Metrology and Measurements

Unit : IV

Topic of Lecture: Applications of Roundness Measurements

Introduction :

This Lecture gives an insight of an in-line inspection of roundness error using machine vision. The system is developed with a machine vision (camera), work holding tools, lighting device and also image processing software for roundness evaluation. An automotive camshaft has been taken as a sample of the cylindrical part.

Prerequisite knowledge for Complete understanding and learning of Topic:

Tolerances
GD & T

Detailed content of the Lecture:

Vision based inspection method for roundness error of a machined part through an in-line approach. The objective is to investigate the roundness error using a developed model for in-line inspection. In-line inspection of the roundness error in this study was initiated based on the preliminary experiment performed in the laboratory. A special test rig was developed to provide for work holding and rotational motion of the automotive camshaft as a sample for cylindrical machined part. The developed test-rig consists of hardware and software that were integrated to perform the non-contact approach of the roundness measurement. Proper lighting technique and arrangement is required in order to have high contrast image quality of the particular details in the sample part. Theoretically, roundness measurement only applied to a circular cross section of cylindrical or tapered shaft or hole. Therefore, a section of the camshaft with cylindrical shape feature has been focused for its roundness error. In this research, cylindrical region with nominal diameter of 46 mm has been targeted during image acquisition and processing.

The configuration of the system and how the motor, encoder and CCD camera were interfaced to the computer is shown in Figure 1(a). Basically the dynamic components of the system consist of bearing, fixed centre, belt and gear, and they were driven by a DC motor. The function of fixed centres is to hold the camshaft at both ends. The basic vision system consist of a CCD camera, image processing software, an image processing algorithm, an image processing board and a computer. Back lighting technique is used in order to obtain clear and sharp images of the part's outer profile. Backlighting generates instant contrast as it creates dark silhouettes against a bright background. The motor and CCD camera were interfaced to the computer via two cards that were slotted into the computer PCI host bus. One of the cards was the interface card connected to a DC motor to control the rotational movement of the camshaft. The other interface card was a frame grabber card where a CCD camera of the vision system was connected to channel available on the card. In order to obtain images at constant incremental angle, the motor was coupled with a rotary encoder. The speed of the motor can be controlled so that steady rotational motion of the shaft can be achieved for better image acquisition. Figure shows the picture of the system calibration and in-situ test-rig for the non-contact roundness measurement system.

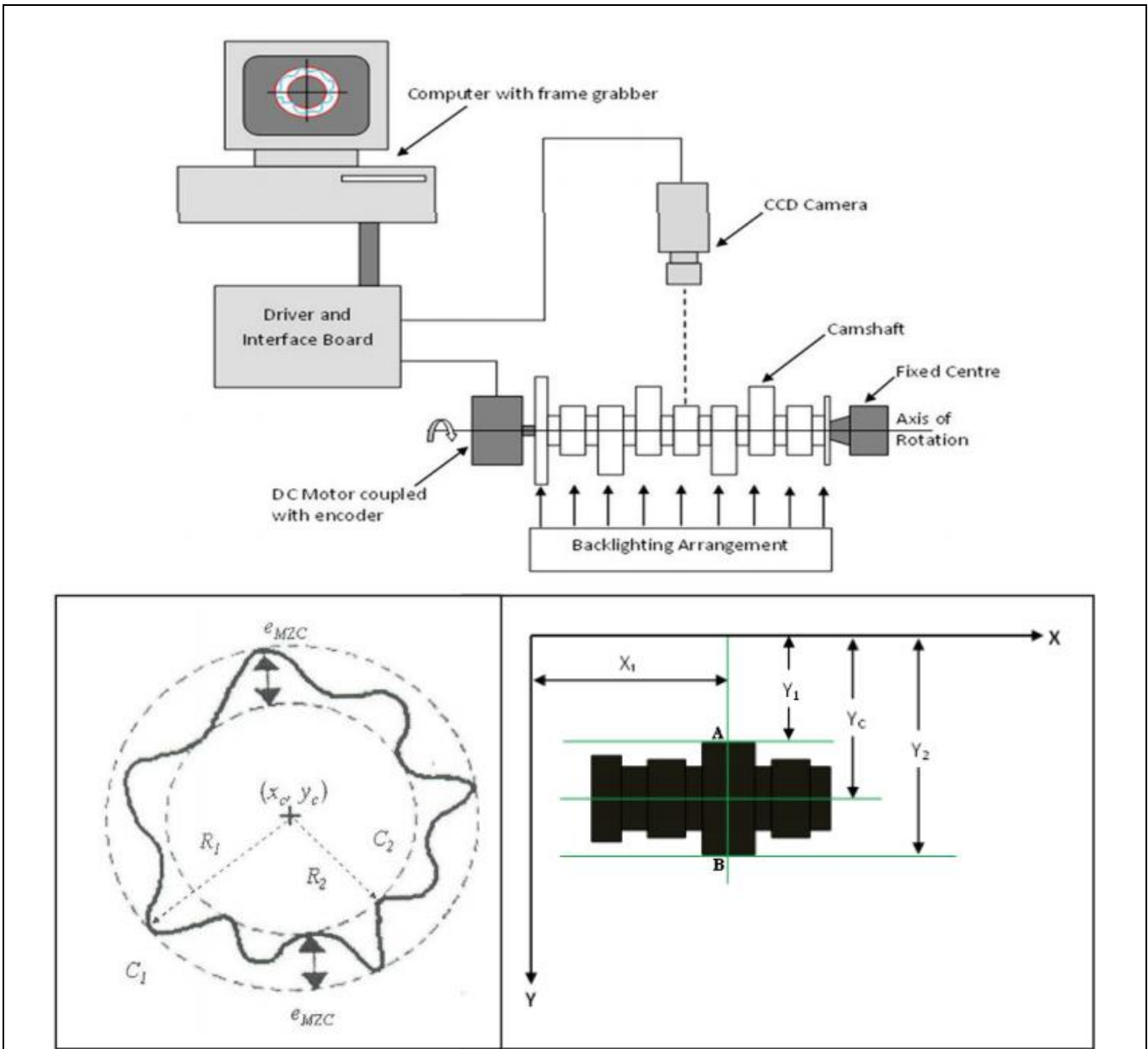

Video Content / Details of website for further learning (if any):

<https://core.ac.uk/download/pdf/82132556.pdf>

Important Books/Journals for further learning including the page nos.:

Jain R.K, Engineering Metrology, Khanna Publishers, 2005 Page no: 506

Course Faculty

Verified by HOD



MUTHAYAMMAL ENGINEERING COLLEGE

(An Autonomous Institution)

(Approved by AICTE, New Delhi, Accredited by NAAC & Affiliated to Anna University)

Rasipuram - 637 408, Namakkal Dist., Tamil Nadu



Course Name : Metrology and Measurements

Unit : V

Topic of Lecture: Force
Introduction : At a very basic level, a force is just a push or a pull. It can be ... Frictional force acts to slow down an object in the direction they are moving.
Prerequisite knowledge for Complete understanding and learning of Topic: Balance, load, Mass
Detailed content of the Lecture: MEASUREMENT OF FORCE The mechanical quantity which changes or tends to change the motion or shape of a body to which it is applied is called force. Force is a basic engineering parameter, the measurement of which can be done in many ways as follows: <input type="checkbox"/> Direct methods <input type="checkbox"/> Indirect methods <input type="checkbox"/> Direct methods It involves a direct comparison with a known gravitational force on a standard mass, say by a balance. <input type="checkbox"/> Indirect methods It involves the measurement of effect of force on a body, such as acceleration of a body of known mass subjected to force. Devices to measure Force Scale and balances a. Equal arm balance b. Unequal arm balance c. Pendulum scale <input type="checkbox"/> Elastic force meter (Proving ring) <input type="checkbox"/> Load cells a. Strain gauge load cell b. Hydraulic load cell c. Pneumatic load cell a. Equal arm balance An equal arm balance works on the principle of moment comparison. The beam of the equal arm balance is in equilibrium position when, Clockwise rotating moment = Anti-clockwise rotating moment $M_2L_2 = M_1L_1$ That is, the unknown force is balanced against the known gravitational force.

The main parts of the arrangement are as follows:

- ☒ A beam whose centre is pivoted and rests on the fulcrum of a knife edge. Either side of the beam is equal in length with respect to the fulcrum
- ☒ A pointer is attached to the center of the beam. This pointer will point vertically downwards when the beam is in equilibrium.
- ☒ A Provision to place masses at either end of the beam.

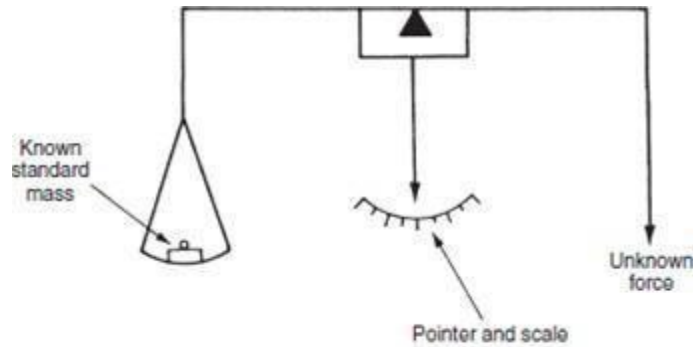

Fig 5.1 Equal Arm Balance

Operation:

- ☒ A known standard mass (m_1) is placed at one end of the beam and an unknown mass (m_2) is placed at its other end.
- ☒ Equilibrium condition exists when, clockwise rotating moment = Anti-clockwise rotating moment
- ☒ Moreover at a given location, the earth's attraction will act equally on both the masses (m_1 and m_2) and hence at equilibrium condition. $W_1 = W_2$. That is, the unknown force (weight) will be equal to the known force (weight).

b. Unequal arm balance

An unequal arm balance works on the principle of moment comparison.

The beam of the unequal arm balance is in equilibrium position when, Clockwise rotating moment = Anti-clockwise rotating moment

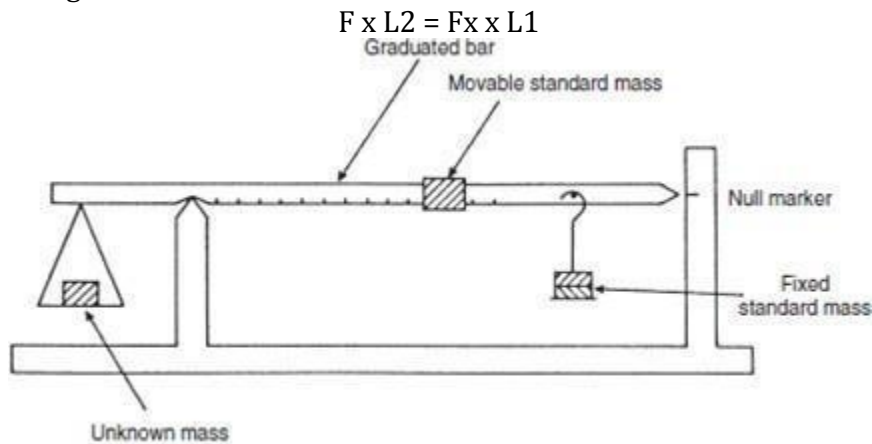

Fig 5.2 Unequal Arm Balance

c. Pendulum Scale (Multi-lever Type)

It is a moment comparison device. The unknown force is converted to torque which is then balanced by the torque of a fixed standard mass arranged as a pendulum.

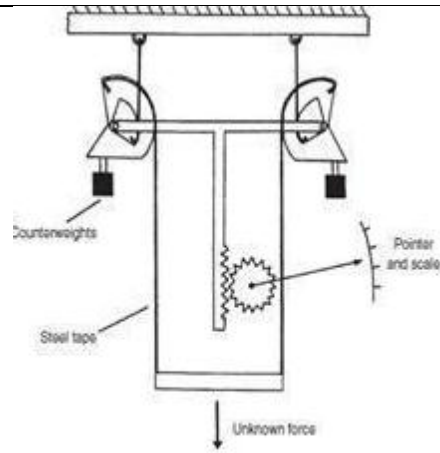

Fig 5.2 Pendulum Scale

Elastic force meter (Proving Ring)

When a steel ring is subjected to a force across its diameter, it deflects. This deflection is proportional to the applied force when calibrated.



Fig 5.4 Proving Ring

Load cells

Construction of Strain Gauge Load Cell

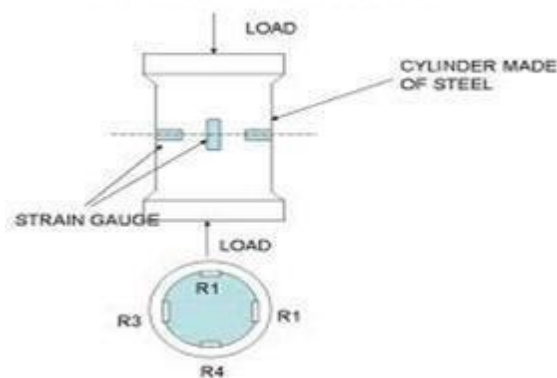

Fig 5.5 Strain Gauge Load Cell

Video Content / Details of website for further learning (if any):

<https://www.youtube.com/watch?v=MQTniyInnsI>

Important Books/Journals For Further Learning Including The Page Nos.: Web Reference

Course Faculty

Verified by HOD



MUTHAYAMMAL ENGINEERING COLLEGE

(An Autonomous Institution)

(Approved by AICTE, New Delhi, Accredited by NAAC & Affiliated to Anna University)

Rasipuram - 637 408, Namakkal Dist., Tamil Nadu



LECTURE HANDOUTS

L - 39

MECH

Year/Sem : III / VI

Course Name : Metrology and Measurements

Unit : V

Topic of Lecture: Torque

Introduction :

Torque, moment, moment of force, rotational force or "turning effect" is the rotational equivalent of linear force. The concept originated with the studies by Archimedes of the usage of levers. Just as a linear force is a push or a pull, a torque can be thought of as a twist to an object. Another definition of torque is the product of the magnitude of the force and the perpendicular distance of the line of action of force from the axis of rotation. $\tau = r \perp F \sin\theta$

Prerequisite knowledge for Complete understanding and learning of Topic:

Force, Direction, Rotation

Detailed content of the Lecture:

- Measurement of applied torques is of fundamental importance in all rotating bodies to ensure that the design of the rotating element is adequate to prevent failure under shear stresses.
- Torque measurement is also a necessary part of measuring the power transmitted by rotating shafts.
- The four methods of measuring torque consist of
- Measuring the strain produced in a rotating body due to an applied torque
- An optical method
- Measuring the reaction force in cradled shaft bearings
- Using equipment known as the Prony brake.

Measurement of Induced Strain

Measuring the strain induced in a shaft due to an applied torque has been the most common method used for torque measurement in recent years. The method involves bonding four strain gauges onto a shaft as shown in Figure, where the strain gauges are arranged in a d.c. bridge circuit.

The output from the bridge circuit is a function of the strain in the shaft and hence of the torque applied. It is very important that positioning of the strain gauges on the shaft is precise, and the difficulty in achieving this makes the instrument relatively expensive. This technique is ideal for measuring the stalled torque in a shaft before rotation commences.

Optical Torque Measurement

Optical techniques for torque measurement have become available recently with the development of laser diodes and fiber-optic light transmission systems. One such system is shown in Figure. Two black-and-white striped wheels are mounted at either end of the rotating shaft and are in alignment when no torque is applied to the shaft.

Light from a laser diode light source is directed by a pair of fiber-optic cables onto the wheels.

The rotation of the wheels causes pulses of reflected light, which are transmitted back to a receiver by a second pair of fiber-optic cables. Under zero torque conditions, the two pulse trains of reflected light are in phase with each other. If torque is now applied to the shaft, the reflected light is modulated.

Measurement by the receiver of the phase difference between the reflected pulse trains therefore allows the magnitude of torque in the shaft to be calculated. The cost of such instruments is relatively low, and an additional advantage in many applications is their small physical size.

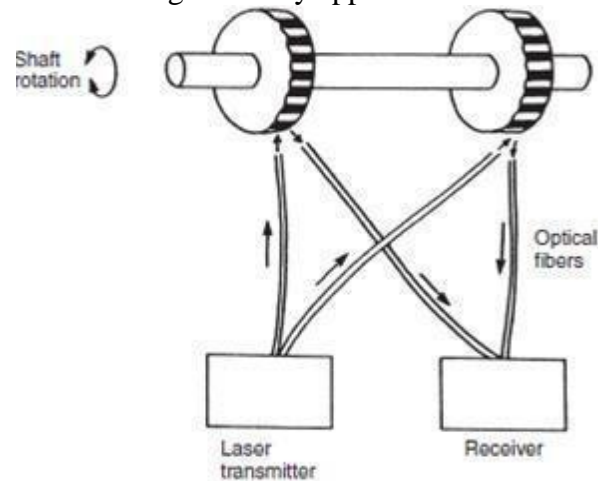

Fig 5.10 Optical Torqu Measurement

Reaction Forces in Shaft Bearings

Any system involving torque transmission through a shaft contains both a power source and a power absorber where the power is dissipated. The magnitude of the transmitted torque can be measured by cradling either the power source or the power absorber end of the shaft in bearings, and then measuring the reaction force, F , and the arm length, L

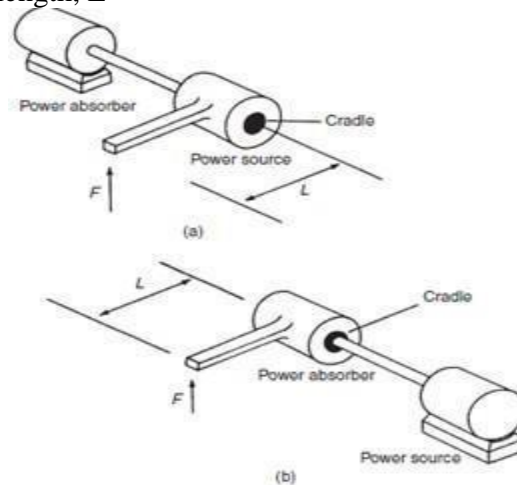

Fig 5.11 Measuring Reaction forces in cradled shaft bearing

Video Content / Details of website for further learning (if any):

<https://www.youtube.com/watch?v=gtEw9LrRoDM>

Important Books/Journals for further learning including the page nos.:

Web Reference

Course Faculty

Verified by HOD



MUTHAYAMMAL ENGINEERING COLLEGE

(An Autonomous Institution)

(Approved by AICTE, New Delhi, Accredited by NAAC & Affiliated to Anna University)

Rasipuram - 637 408, Namakkal Dist., Tamil Nadu



LECTURE HANDOUTS

L - 40

MECH

Year/Sem : III / VI

Course Name : Metrology and Measurements

Unit : V

Topic of Lecture: Power - Mechanical

Introduction :

The power is transmitted from one shaft to the other by means of belts, chains and gears. The belts and ropes are flexible members which are used where distance between the two shafts is large. The chains also have flexibility but they are preferred for intermediate distances.

The gears are used when the shafts are very close with each other. This type of drive is also called positive drive because there is no slip. If the distance is slightly larger, chain drive can be used for making it a positive drive.

Belts and ropes transmit power due to the friction between the belt or rope and the pulley. There is a possibility of slip and creep and that is why, this drive is not a positive drive. A gear train is a combination of gears which are used for transmitting motion from one shaft to another.

Prerequisite knowledge for Complete understanding and learning of Topic:

Torque, Rotational speed

Detailed content of the Lecture:

MEASUREMENT OF POWER

Torque is exerted along a rotating shaft. By measuring this torque which is exerted along a rotating shaft, the shaft power can be determined. For torque measurement dynamometers are used.

$$T = F.r$$

$$P = 2\pi NT$$

Where, T – Torque, F – Force at a known radius r, P – Power

Types of dynamometers

☑ Absorption dynamometers

☑ Driving dynamometers

☑ Transmission dynamometers

Absorption dynamometers

The dynamometer absorbs the mechanical energy when torque is measured. It dissipates mechanical energy (heat due to friction) when torque is measured. Therefore, dynamometers are used to measure torque/power of power sources like engine and motors.

Mechanical Dynamometers

In prony brake, mechanical energy is converted into heat through dry friction between the wooden brake blocks and the flywheel (pulley) of the machine. One block carries a lever arm. An arrangement is provided to tighten the rope which is connected to the arm. Rope is tightened so as to increase the frictional resistance between the blocks and the pulley.

Power dissipated, $P = 2\pi NT/60$

The capacity of prony brake is limited due to wear of wooden blocks, friction coefficient varies. So, it is unsuitable for large powers when it is used for long periods.

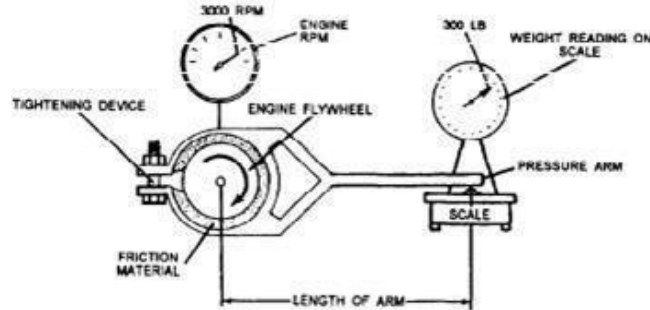

Fig 5.13 Mechanical Dynamometer

Eddy Current Dynamometer

An eddy current dynamometer is shown above. It consists of a metal disc or wheel which is rotated in the flux of a magnetic field. The field is produced by field elements or coils excited by an external source and attached to the dynamometer housing which is mounted in trunnion bearings. As the disc turns, eddy currents are generated. Its reaction with the magnetic field tends to rotate the complete housing in the trunnion bearings. Water cooling is employed.

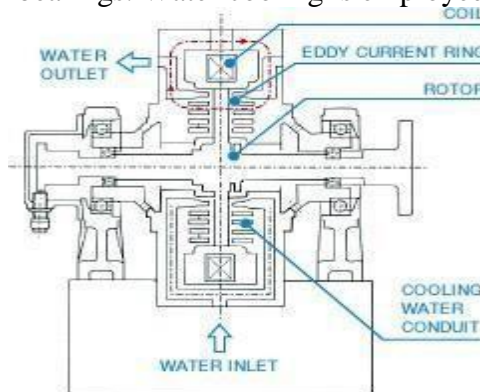

Fig 5.14 Eddy current Dynamometer

Hydraulic or Fluid Friction Dynamometer

A rotating disk that is fixed to the driving shaft, Semi-elliptical grooves are provided on the disc through which a stream of water flows. There is a casting which is stationary and the disc rotates in this casing. When the driving shaft rotates, water flow is in a helical path in the chamber. Due to vortices and eddy-currents setup in the water, the casting tends to rotate in the same direction as that of the driving shafts. By varying the amount of water, the braking action is provided. Braking can also be provided by varying the distance between the rotating disk and the casting. The absorbing element is 98 constrained by a force-measuring device placed at the end of the arm of radius .

Video Content / Details of website for further learning (if any):

<https://www.youtube.com/watch?v=rOsTrndLLS8>

Important Books/Journals for further learning including the page nos.:

Web Reference



MUTHAYAMMAL ENGINEERING COLLEGE

(An Autonomous Institution)

(Approved by AICTE, New Delhi, Accredited by NAAC & Affiliated to Anna University)

Rasipuram - 637 408, Namakkal Dist., Tamil Nadu

Verified by HOD



LECTURE HANDOUTS

L - 41

MECH

Year/Sem : III / VI

Course Name : Metrology and Measurements

Unit : V

Topic of Lecture: Power - Pneumatic, Hydraulic

Introduction :

In the industry we use three methods for transmitting power from one point to another. Mechanical transmission is through shafts, gears, chains, belts, etc. Electrical transmission is through wires, transformers, etc. Fluid power is through liquids or gas in a confined space. In this chapter, we shall discuss a structure of hydraulic systems and pneumatic systems. We will also discuss the advantages and disadvantages and compare hydraulic, pneumatic, electrical and mechanical systems.

Prerequisite knowledge for Complete understanding and learning of Topic:

Fluid, Power, Air, Compression, Oil

Detailed content of the Lecture:

Learning Objectives

Upon completion of this chapter, the student should be able to: Explain the meaning of fluid power. List the various applications of fluid power. Differentiate between fluid power and transport systems. List the advantages and disadvantages of fluid power. Explain the industrial applications of fluid power. List the basic components of the fluid power. List the basic components of the pneumatic systems. Differentiate between electrical, pneumatic and fluid power systems. Appreciate the future of fluid power in India.

Basic Components of a Hydraulic System

Hydraulic systems are power-transmitting assemblies employing pressurized liquid as a fluid for transmitting energy from an energy-generating source to an energy-using point to accomplish useful work. Figure shows a simple circuit of a hydraulic system with basic components.

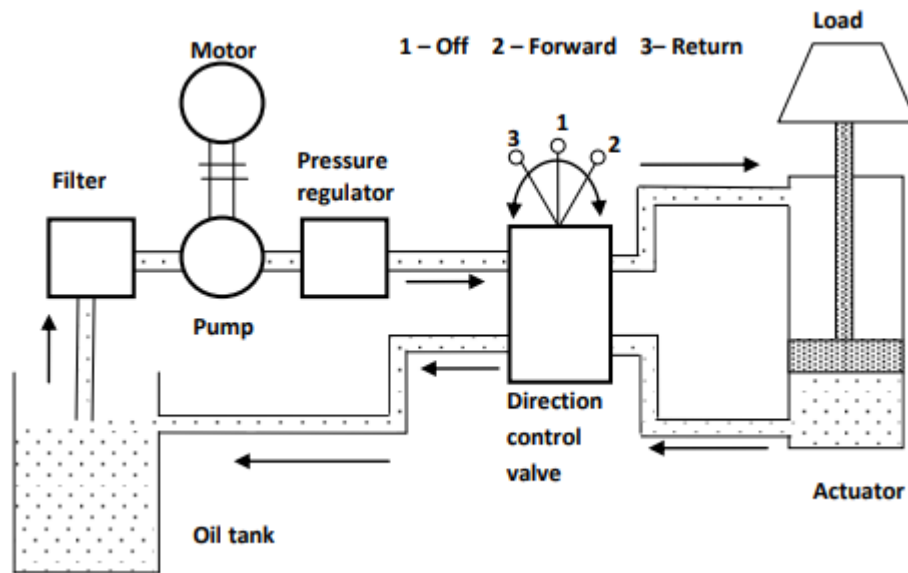

Functions of the components shown in Fig. are as follows:

1. The hydraulic actuator is a device used to convert the fluid power into mechanical power to do useful work. The actuator may be of the linear type (e.g., hydraulic cylinder) or rotary type (e.g., hydraulic motor) to provide linear or rotary motion, respectively.
2. The hydraulic pump is used to force the fluid from the reservoir to rest of the hydraulic circuit by converting mechanical energy into hydraulic energy.
3. Valves are used to control the direction, pressure and flow rate of a fluid flowing through the circuit.
4. External power supply (motor) is required to drive the pump.
5. Reservoir is used to hold the hydraulic liquid, usually hydraulic oil.
6. Piping system carries the hydraulic oil from one place to another.
7. Filters are used to remove any foreign particles so as keep the fluid system clean and efficient, as well as avoid damage to the actuator and valves.
8. Pressure regulator regulates (i.e., maintains) the required level of pressure in the hydraulic fluid.

The piping shown in Fig. is of closed-loop type with fluid transferred from the storage tank to one side of the piston and returned back from the other side of the piston to the tank.

Fluid is drawn from the tank by a pump that produces fluid flow at the required level of pressure. If the fluid pressure exceeds the required level, then the excess fluid returns back to the reservoir and remains there until the pressure acquires the required level.

Basic Components of a Pneumatic System

A pneumatic system carries power by employing compressed gas, generally air, as a fluid for transmitting energy from an energy-generating source to an energy-using point to accomplish useful work. Figure shows a simple circuit of a pneumatic system with basic components.

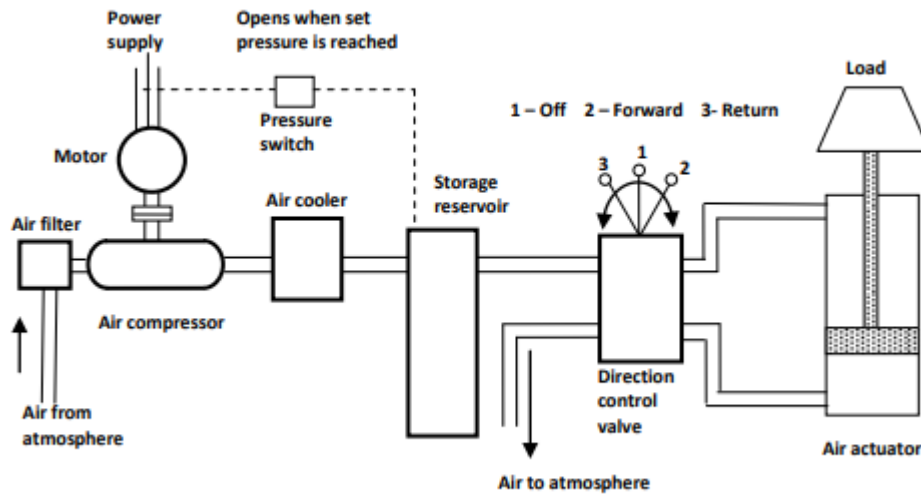

The functions of various components shown in Fig. are as follows:

1. The pneumatic actuator converts the fluid power into mechanical power to perform useful work.
2. The compressor is used to compress the fresh air drawn from the atmosphere.
3. The storage reservoir is used to store a given volume of compressed air.
4. The valves are used to control the direction, flow rate and pressure of compressed air.
5. External power supply (motor) is used to drive the compressor.
6. The piping system carries the pressurized air from one location to another. Air is drawn from the atmosphere through an air filter and raised to required pressure by an air compressor.

As the pressure rises, the temperature also rises; hence, an air cooler is provided to cool the air with some preliminary treatment to remove the moisture.

The treated pressurized air then needs to get stored to maintain the pressure. With the storage reservoir, a pressure switch is fitted to start and stop the electric motor when pressure falls and reaches the required level, respectively.

The three-position change over the valve delivering air to the cylinder operates in a way similar to its hydraulic circuit.

Video Content / Details of website for further learning (if any):

<https://www.youtube.com/watch?v=72aTr47b-Io>

Important Books/Journals for further learning including the page nos.:

Web Reference

Course Faculty

Verified by HOD



MUTHAYAMMAL ENGINEERING COLLEGE

(An Autonomous Institution)

(Approved by AICTE, New Delhi, Accredited by NAAC & Affiliated to Anna University)

Rasipuram - 637 408, Namakkal Dist., Tamil Nadu



LECTURE HANDOUTS

L - 42

MECH

Year/Sem : III / VI

Course Name : Metrology and Measurements

Unit : V

Topic of Lecture: Power - Electrical type.

Introduction :

The rate at which the work is being done in an electrical circuit is called an electric power. In other words, the electric power is defined as the rate of the transferred of energy. The electric power is produced by the generator and can also be supplied by the electrical batteries. It gives a low entropy form of energy which is carried over long distance and also it is converted into various other forms of energy like motion, heat energy, etc.

Prerequisite knowledge for Complete understanding and learning of Topic:

Power, Time, Watt, Voltage, Work done, Energy

Detailed content of the Lecture:

Definition: The rate at which the work is being done in an electrical circuit is called an electric power. In other words, the electric power is defined as the rate of the transferred of energy. The electric power is produced by the generator and can also be supplied by the electrical batteries. It gives a low entropy form of energy which is carried over long distance and also it is converted into various other forms of energy like motion, heat energy, etc.

The electric power is divided into two types, i.e., the AC power and the DC power. The classification of the electric power depends on the nature of the current. The electric power is sold regarding joule which is the product of the power in kilowatts and the running time of the machinery in hours. The utility of power is measured by the electric meter which records the total energy consumed by the powered devices. The electric power is given by the equation shown below.

$$\text{Electrical Power} = \frac{\text{Work done in an electrical current}}{\text{time}}$$

$$P = \frac{VIt}{t} = VI = IR^2 = \frac{V^2}{R}$$

Where **V** is the voltage in volts, **I** is the current in amperes, **R** is the resistance offered by the powered devices, **T** is the time in seconds and the **P** is the power measured in watts.

Unit of Electric Power

The unit of electrical power is Watt.

$$V = 1 \text{ volts and } I = 1 \text{ ampere}$$

$$P = 1 \text{ watt}$$

Thus, the power consumed in an electrical circuit is said to one watt if one ampere current flows through the circuit when a potential difference of 1 volt is applied across it. The bigger unit of electrical power is the kilowatt (kW), it is usually used in the power system

$$1kW = 1000W$$

Types of an Electric Power

The electrical power is mainly classified into two types. They are the DC power and the AC power.

1. DC Power

The DC power is defined as the product of the voltage and current. It is produced by the fuel cell, battery and generator.

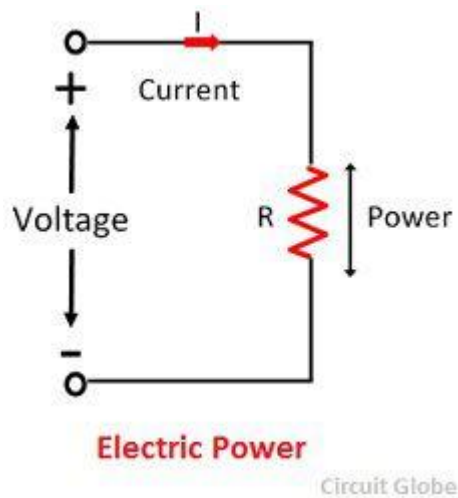

$$P = V \times I$$

Where P – Power in watt.

V – voltage in volts.

I – current in amps.

2. AC Power

The AC power is mainly classified into three types. They are the apparent power, active power and real power.

1. Apparent Power – The apparent power is the useless power or idle power. It is represented by the symbol S, and their SI unit is volt-amp.

$$S = V_{rms}I_{rms}$$

Where S – apparent power

V_{rms} – RMS voltage = $V_{peak}\sqrt{2}$ in volt.

I_{rms} – RMS current = $I_{peak}\sqrt{2}$ in the amp.

2. Active Power – The active power (P) is the real power which is dissipated in the circuit **resistance**.

$$P = V_{max}I_{max}\cos\Phi$$

Where, P – the real power in watts.

V_{rms} – RMS voltage = $V_{peak}\sqrt{2}$ in volts.

I_{rms} – RMS current = $I_{peak}\sqrt{2}$ in the amp.

Φ – impedance phase angle between voltage and current.

3. Reactive Power – The power developed in the circuit reactance is called reactive power (Q). It is measured in volt-ampere reactive.

$$Q = V_{rms}I_{rms}\sin\Phi$$

Where, Q – the reactive power in watts.

V_{rms} – RMS voltage = $V_{peak}\sqrt{2}$ in volt.

I_{rms} – RMS current = $I_{peak}\sqrt{2}$ in the amp.

Φ – impedance phase angle between voltage and current.

The relation between the apparent, active and reactive power is shown below.

$$S^2 = Q^2 + P^2$$

The ratio of the real to the apparent power is called power factor, and their value lies between 0 and 1

Video Content / Details of website for further learning (if any):

https://www.youtube.com/watch?v=gL2SAbB_MKU

Important Books/Journals for further learning including the page nos.:

Web Reference

Course Faculty

Verified by HOD

LECTURE HANDOUTS

L - 43

MECH

Year/Sem : III / VI

Course Name : Metrology and Measurements

Unit : V

Topic of Lecture: Flow measurement: Venturimeter, Orifice meter, rotameter, pitot tube

Introduction :

There are many different meters used to measure fluid flow: the turbine-type flow meter, the Rotameter, the orifice meter, and the venturi meter are only a few. Each meter works by its ability to alter a certain physical property of the flowing fluid and then allows this alteration to be measured. The measured alteration is then related to the flow. The subject of this experiment is to analyze the features of certain meters.

Prerequisite knowledge for Complete understanding and learning of Topic:

Measurement, Pressure, Velocity, Density

Detailed content of the Lecture:

Venturi Meter

Venturi tubes are differential pressure producers, based on Bernoulli's Theorem. General performance and calculations are similar to those for orifice plates. In these devices, there is a continuous contact between the fluid flow and the surface of the primary device.

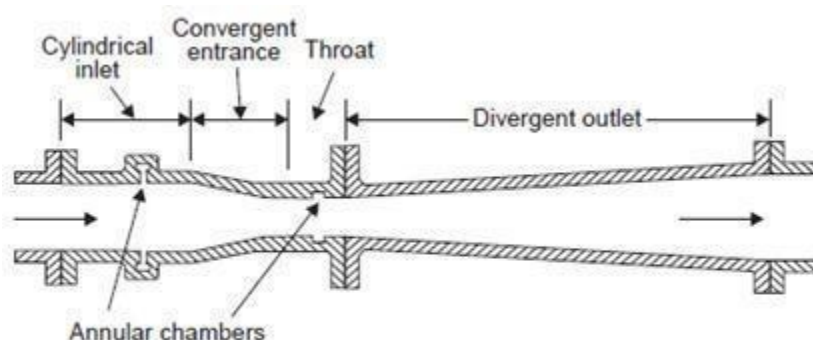

Fig 5.18 Long form Venturi

Limitations

This flow meter is limited to use on clean, non-corrosive liquids and gases, because it is impossible to clean out or flush out the pressure taps if they clog up with dirt or debris.

Form Limitations

This flow meter is limited to use on clean, non- corrosive liquids and gases, because it is impossible to clean out or flush out the pressure taps if they clog up with dirt or debris.

Short Form

where

$$\dot{Q} = a_2 \sqrt{\frac{2(p_1 - p_2)}{\rho(1 - \beta^4)}}$$

p is pressure (N/m²)
 v is velocity (m/s)
 ρ is the density of the liquid (kg/m³).

β is the ratio: $\frac{\text{throat diameter}}{\text{pipe diameter}}$

$$\therefore \dot{Q} = \frac{a_1 a_2}{\sqrt{(a_1^2 - a_2^2)}} \sqrt{\frac{2}{\rho} (p_1 - p_2)} \text{ m}^3/\text{s}$$

Limitations

This flow meter is limited to use on clean, non- corrosive liquids and gases, because it is impossible to clean out or flush out the pressure taps if they clog up with dirt or debris.

In an effort to reduce costs and laying length, manufactures developed a second generation, or short-form venturi tubes shown in Figure.

There were two major differences in this design. The internal annular chamber was replaced by a single pressure tap or in some cases an external pressure averaging chamber, and the recovery cone angle was increased from 7 degrees to 21 degrees.

The short form venture tubes can be manufactured from cast iron or welded from a variety of materials compatible with the application.

The pressure taps are located one-quarter to one-half pipe diameter upstream of the inlet cone and at the middle of the throat section. A piezometer ring is sometimes used for differential pressure measurement.

This consists of several holes in the plane of the tap locations. Each set of holes is connected together in an annular ring to give an average pressure. Venturis with piezometer connections are unsuitable for use with purge systems used for slurries and dirty fluids since the purging fluid tends to short circuit to the nearest tap holes.

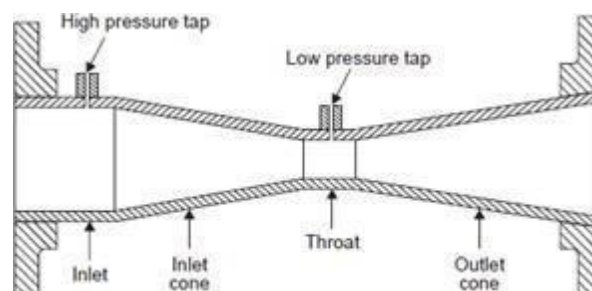

Fig 5.19 Short-form Venturi Tube

Rotameter

The orificemeter, Venturimeter and flow nozzle work on the principle of constant area variable pressure drop. Here the area of obstruction is constant, and the pressure drop changes with flow rate. On the other hand Rotameter works as a constant pressure drop variable area meter.

It can be only be used in a vertical pipeline. Its accuracy is also less (2%) compared to other types of flow meters. But the major advantages of rotameter are, it is simple in construction, ready to install and the flow rate can be directly seen on a calibrated scale, without the help of any other device, e.g. differential pressure sensor etc. Moreover, it is useful for a wide range of variation of flow rates (10:1). The basic construction of a rotameter is shown in figure.

It consists of a vertical pipe, tapered downward. The flow passes from the bottom to the top. There is cylindrical type metallic float inside the tube. The fluid flows upward through the gap between the tube and the float. As the float moves up or down there is a change in the gap, as a result. changing the area of the orifice.

In fact, the float settles down at a position, where the pressure drop across the orifice will create an upward thrust that will balance the downward force due to the gravity. The position of the float is calibrated with the flow rate.

Force acting on float

Rotameter

γ_1 = Specific weight of the float γ_2 = specific weight of the fluid v = volume of the float A_f = Area of the float.

A_t = Area of the tube at equilibrium (corresponding to the dotted line)

F = Downward thrust on the float

F = Upward thrust on the float

The major source of error in rotameter is due to the variation of density of the fluid. Besides, the presence of viscous force may also provide an additional force to the float. 105

Applications

- ☒ Can be used to measure flow rates of corrosive fluids
- ☒ Particularly useful to measure low flow rates

Advantages

- ☒ Flow conditions are visible
- ☒ Flow rate is a linear function (uniform flow scales)
- ☒ Can be used to measure flow rates of liquids, gases and vapour
- ☒ By changing the float, tapered tube or both, the capacity of the rotameter can be changed.

Limitations

- ☐ They should be installed vertically
- ☐ They cannot be used for measurements in moving objects
- ☐ The float will not be visible when coloured fluids are used, that is, when opaque fluid are used.
- ☐ For high pressure and temperature fluid flow measurements, they are expensive
- ☐ They cannot be used for fluids containing high percentage of solids in suspension

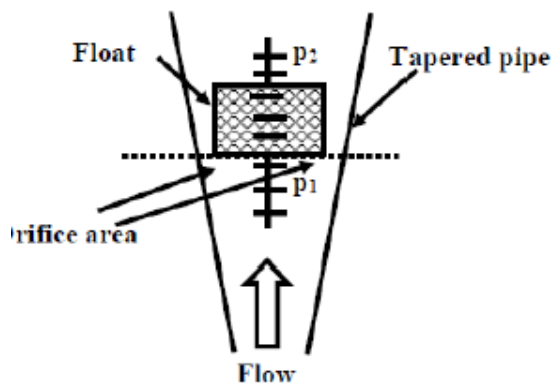

Fig 5.23 Rotameter

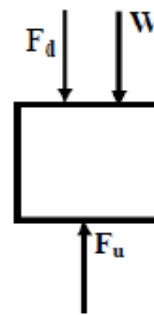

Fig 5.24 Force acting on float

Video Content/ Details of website for further learning (if any):

<https://www.youtube.com/watch?v=FkW6RLwpOeA>

Important Books/Journals for further learning including the page nos.:

Web Reference

Course Faculty

Verified by HOD



MUTHAYAMMAL ENGINEERING COLLEGE

(An Autonomous Institution)

(Approved by AICTE, New Delhi, Accredited by NAAC & Affiliated to Anna University)

Rasipuram - 637 408, Namakkal Dist., Tamil Nadu



LECTURE HANDOUTS

L - 44

MECH

Year/Sem : III / VI

Course Name : Metrology and Measurements

Unit : V

Topic of Lecture: Temperature: bimetallic strip, thermocouples, electrical resistance thermometer

Introduction :

Temperature is a physical property of matter that quantitatively expresses the hotness or coldness of an object or a process. The objects of low temperature are cold, while various degrees of higher temperatures are referred to as warm or hot.

For most temperature measurements the Celsius scale is used. The freezing point of water in the Celsius scale is 0°C and boiling point is 100°C . The Celsius scale has the same incremental scaling as the Kelvin scale, however, the 0°C on Celsius scale is equal to 273.15K .

A few countries, most notably The United States, use the Fahrenheit scale for common purposes. On this scale the freezing point of water is 32°F and the boiling point is 212°F .

Several methods have been developed for measuring temperature. Most of these methods depend upon measuring some physical property of a working material that varies with temperature.

One of the most common devices for measuring temperature is the glass thermometer. Other important temperatures measuring transducers are the bimetallic strips, resistance temperature detector, thermocouples, thermistor, pyrometers etc.

Prerequisite knowledge for Complete understanding and learning of Topic:

Temperature, Power, Resistance

Detailed content of the Lecture:

TEMPERATURE MEASUREMENT

Temperature is one of the most measured physical parameters in science and technology; typically for process thermal monitoring and control. There are many ways to measure temperature, using various principles.

Four of the most common are:

☑ Mechanical (liquid-in-glass thermometers, bimetallic strips, etc.)

☑ Thermo-junctive (thermocouples)

☑ Thermoresistive (RTDs and thermistors)

☑ Radiative (infrared and optical pyrometers)

Mechanical Temperature Measuring Devices

A change in temperature causes some kind of mechanical motion, typically due to the fact that most materials expand with a rise in temperature. Mechanical thermometers can be constructed that use liquids, solids, or even gases as the temperature-sensitive material.

The mechanical motion is read on a physical scale to infer the temperature.

Bimetallic strip thermometer

☐ Two dissimilar metals are bonded together into what is called a bimetallic strip, as sketched to the right.

☐ Suppose metal A has a smaller coefficient of thermal expansion than does metal B. As temperature increases, metal B expands more than does metal A, causing the bimetallic strip to curl upwards as sketched.

☐ One common application of bimetallic strips is in home thermostats, where a bimetallic strip is used as the arm of a switch between electrical contacts. As the room temperature changes, the bimetallic strip bends as discussed above. When the bimetallic strip bends far enough, it makes contact with electrical leads that turn the heat or air conditioning on or off.

☐ Another application is in circuit breakers. High temperature indicates over-current, which shuts off the circuit.

☐ Another common application is for use as oven, wood burner, or gas grill thermometers. These thermometers consist of a bimetallic strip wound up in a spiral, attached to a dial that is calibrated into a temperature scale.

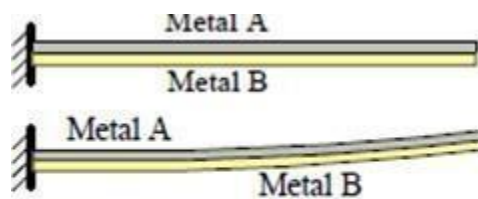

Fig 5.25 Bimetallic Strip

Pressure thermometer

☐ A pressure thermometer, while still considered mechanical, operates by the expansion of a gas instead of a liquid or solid. There are also pressure thermometers that use a liquid instead of a gas

☐ Specific gas constant R is a constant. The bulb and tube are of constant volume, so V is a constant. Also, the mass m of gas in the sealed bulb and tube must be constant (conservation of mass).

☐ A pressure thermometer therefore measures temperature indirectly by measuring pressure.

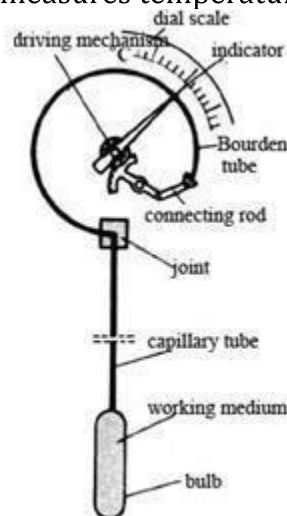

Fig 5.26 Pressure Thermometer

THERMOCOUPLES (Thermo-junctive temperature measuring devices)

Thomas Johan Seebeck discovered in 1821 that thermal energy can produce electric current. When two conductors made from dissimilar metals are connected forming two common junctions and the two junctions are exposed to two different temperatures, a net thermal emf is produced, the actual value being dependent on the materials used and the temperature difference between hot and cold junctions. The thermoelectric emf generated, in fact is due to the combination of two effects: Peltier effect and Thomson effect. A typical thermocouple junction is shown in fig. The emf generated can be approximately expressed by the relationship:

Where, T_1 and T_2 are hot and cold junction temperatures in K. C_1 and C_2 are constants depending upon the materials. For Copper/ Constantan thermocouple, $C_1=62.1$ and $C_2=0.045$. Thermocouples are extensively used for measurement of temperature in industrial situations. The major reasons behind their popularity are:

(i) They are rugged and readings are consistent

(ii) They can measure over a wide range of temperature

(iii) Their characteristics are almost linear with an accuracy of about 0.05%. However, the major shortcoming of thermocouples is low sensitivity compared to other temperature measuring devices (e.g. RTD, Thermistor).

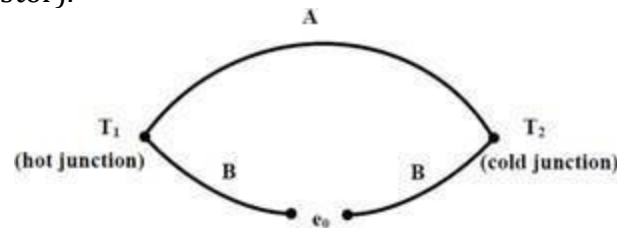

Fig 5.27 Thermocouple

Laws of Thermocouple

The Peltier and Thompson effects explain the basic principles of thermoelectric emf generation. But they are not sufficient for providing a suitable measuring technique at actual measuring situations. For this purpose, we have three laws of thermoelectric circuits that provide us useful practical tips for measurement of temperature. These laws are known as law of homogeneous circuit, law of intermediate metals and law of intermediate temperatures. These laws can be explained using figure

The first law can be explained using figure (a). It says that the net thermo-emf generated is dependent on the materials and the temperatures of two junctions only, not on any intermediate temperature.

According to the second law, if a third material is introduced at any point (thus forming two additional junctions)

it will not have any effect, if these two additional junctions remain at the same temperatures (figure b). This law makes it possible to insert a measuring device without altering the thermo-emf.

THERMORESISTIVE TEMPERATURE MEASURING DEVICES

Principle of operation

☐ A change in temperature causes the electrical resistance of a material to change.

☐ The resistance change is measured to infer the temperature change.

☐ There are two types of thermoresistive measuring devices: resistance temperature detectors and thermistors, both of which are described here.

THERMORESISTIVE TEMPERATURE MEASURING DEVICES

Principle of operation

☐ A change in temperature causes the electrical resistance of a material to change.

☐ The resistance change is measured to infer the temperature change.

☐ There are two types of thermoresistive measuring devices: resistance temperature detectors and thermistors, both of which are described here.

Resistance temperature detectors

A resistance temperature detector (abbreviated RTD) is basically either a long, small diameter metal wire 109

(usually platinum) wound in a coil or an etched grid on a substrate, much like a strain gauge.

The resistance of an RTD increases with increasing temperature, just as the resistance of a strain gage increases with increasing strain.

If the temperature changes are large, or if precision is not critical, the RTD resistance can be

measured directly to obtain the temperature. If the temperature changes are small, and/or high precision is needed, an electrical circuit is built to measure a change in resistance of the RTD, which is then used to calculate a change in temperature. One simple circuit is the quarter bridge Wheatstone bridge circuit, here called a two-wire RTD bridge circuit

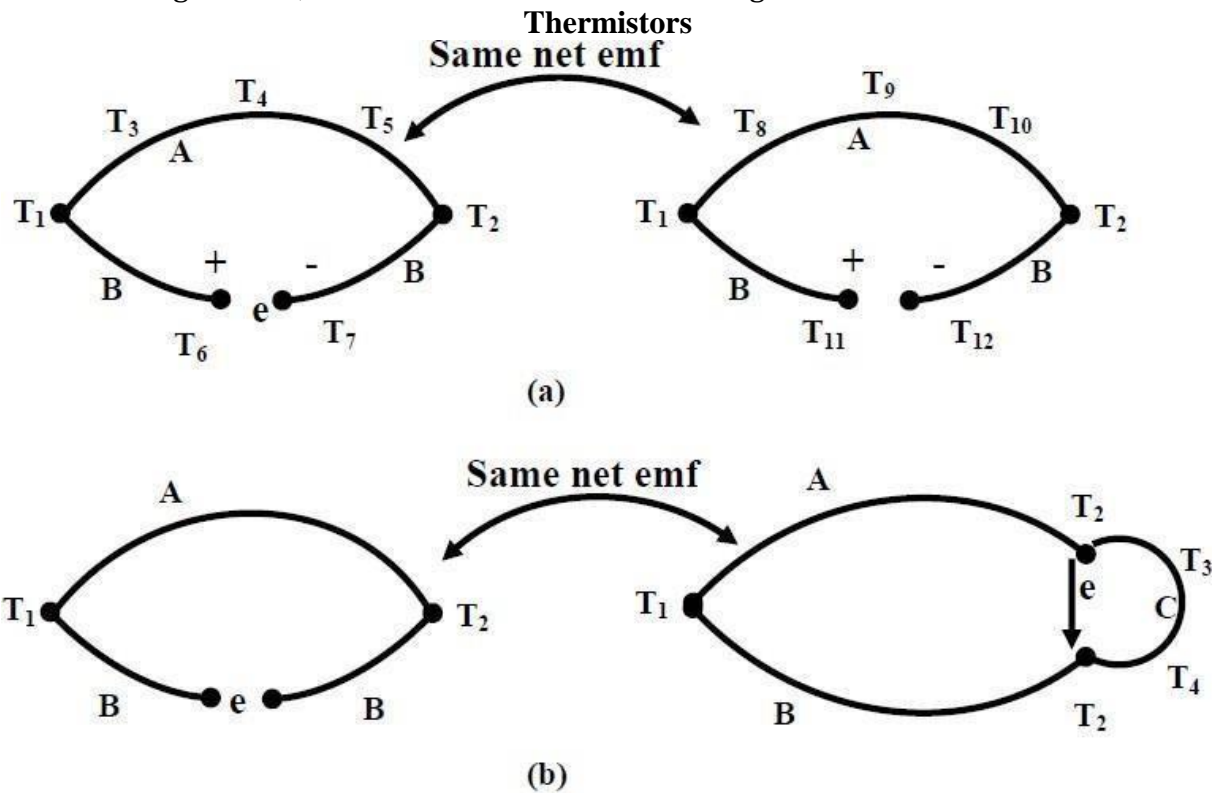

THERMORESISTIVE TEMPERATURE MEASURING DEVICES

Principle of operation

- ☒ A change in temperature causes the electrical resistance of a material to change.
- ☒ The resistance change is measured to infer the temperature change.
- ☒ There are two types of thermoresistive measuring devices: resistance temperature detectors and thermistors, both of which are described here.

Resistance temperature detectors

A resistance temperature detector (abbreviated RTD) is basically either a long, small diameter metal wire 109

(usually platinum) wound in a coil or an etched grid on a substrate, much like a strain gauge.

The resistance of an RTD increases with increasing temperature, just as the resistance of a strain gage increases with increasing strain.

If the temperature changes are large, or if precision is not critical, the RTD resistance can be measured directly to obtain the temperature. If the temperature changes are small, and/or high precision is needed, an electrical circuit is built to measure a change in resistance of the RTD, which is then used to calculate a change in temperature. One simple circuit is the quarter bridge Wheatstone bridge circuit, here called a two-wire RTD bridge circuit

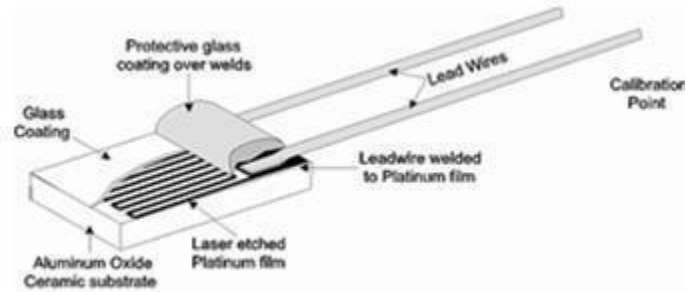
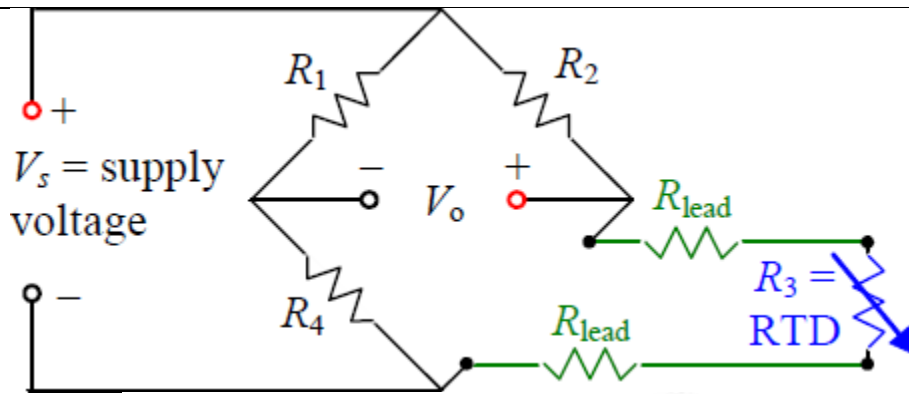
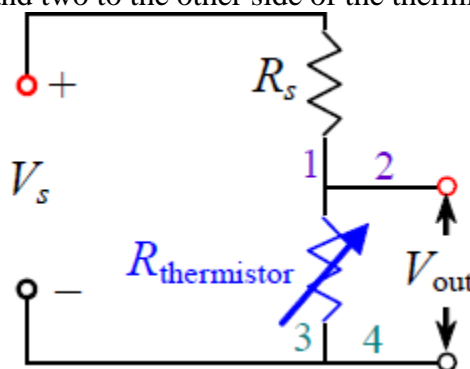

Fig 5.28 RTD

Thermistors

A thermistor is similar to an RTD, but a semiconductor material is used instead of a metal. A thermistor is a solid state device. Resistance thermometry may be performed using thermistors. Thermistors are many times more sensitive than RTD's and hence are useful over limited ranges of temperature. They are small pieces of ceramic material made by sintering mixtures of metallic oxides of Manganese, Nickel, Cobalt, Copper and Iron etc. 3 or 4 lead wires for convenience in wiring – two wires are connected to one side and two to the other side of the thermistor (labeled 1, 2 and 3, 4 above).



Video Content / Details of website for further learning (if any):

<https://www.youtube.com/watch?v=bmBeD5c7n6Q>

Important Books/Journals for further learning including the page nos.:

Web Reference

Course Faculty

Verified by HOD



MUTHAYAMMAL ENGINEERING COLLEGE

(An Autonomous Institution)

(Approved by AICTE, New Delhi, Accredited by NAAC & Affiliated to Anna University)

Rasipuram - 637 408, Namakkal Dist., Tamil Nadu



LECTURE HANDOUTS

L - 45

MECH

Year/Sem : III / VI

Course Name : Metrology and Measurements

Unit : V

Topic of Lecture: Reliability and Calibration – Readability and Reliability

Introduction :

Reliability is defined (Portney and Watkins, 2000) as: 'the extent to which a measurement is consistent and free from error'. 'Consistency' means that the outcome measure will produce the same results on two or more occasions in a cohort whose status has not changed. 'Free from error' means that when a reliable outcome measure detects differences in patients over two more occasions, this is a result of a change in physical performance rather than measurement error.

Prerequisite knowledge for Complete understanding and learning of Topic:

Standard, units, accuracy, precision

Detailed content of the Lecture:

Calibration

Is the comparison of measurement values delivered by a device under test with those of a calibration standard of known accuracy. Such a standard could be another measurement device of known accuracy, a device generating the quantity to be measured such as a voltage, a sound tone, or a physical artifact, such as a meter ruler.

The outcome of the comparison can result in one of the following:

- no significant error being noted on the device under test
- a significant error being noted but no adjustment made
- an adjustment made to correct the error to an acceptable level

Strictly speaking, the term "calibration" means just the act of comparison and does not include any subsequent adjustment.

The need for calibration Measurement

Is vital in science, industry and commerce. Measurement is also performed extensively in our daily life. The following are some examples:

- Measurements for health care, such as measuring body temperature with a clinical thermometer, checking blood pressure and many other tests;
- Checking the time of day; • Buying cloth for dresses;
- Purchase of vegetables and other groceries;
- Billing of power consumption through an energy meter.

Accuracy and reliability of all such measurements would be doubtful if the instruments used were not calibrated. Calibration ensures that a measuring instrument displays an accurate and reliable value of the quantity being measured. Thus, calibration is an essential activity in any measurement process.

Reliability

In [statistics](#) and psychometrics is the overall consistency of a measure. A measure is said to have a high reliability if it produces similar results under consistent conditions. "It is the characteristic of a set of test scores that relates to the amount of random error from the measurement process that might be embedded in the scores. Scores that are highly reliable are accurate, reproducible, and consistent from one testing occasion to another.

That is, if the testing process were repeated with a group of test takers, essentially the same results would be obtained. Various kinds of reliability coefficients, with values ranging between 0.00 (much error) and 1.00 (no error), are usually used to indicate the amount of error in the scores." ^[2] For example, measurements of people's height and weight are often extremely reliable.

Reliability Of Measurement

Whenever measurements are made, it is with the objective of generating data. The data is then analysed and compared with requirements so that an appropriate decision can be taken, such as to accept, rework or reject the product.

However, unless the measurement data is reliable, decisions based on such data cannot be reliable either. Consequently, these actions contribute enormously to the cost of quality a manufacturer has to bear.

Characteristics of data reliability

For measurement data to be reliable, measurement should be: • Accurate • Precise • Reproducible
Accuracy: The closeness of the agreement between the result of a measurement and a true value of the measurand.

For example, when the accuracy of a micrometer with a range of 0-25 mm and a least count of 1 μ is stated as $\pm 4 \mu$, it means that if this micrometer gives a reading of 20.255 mm, the actual or true value of the measurand can be $20.255 \text{ mm} \pm 4 \mu$, i.e. between 20.251 and 20.259 mm. Precision:

The closeness of the agreement between the results of successive measurements of the same measurand carried out under the same conditions of measurement. Precision is also called repeatability.

For example, if the above micrometer is used to measure the diameter of a steel pin a number of times at a certain point and the values of 20.253, 20.252, 20.250, 20.251 mm are obtained, then the precision or the repeatability of the measurement can be stated as 0.003 mm (20.253 – 20.250 mm).

For example, if the above steel pin is measured for its diameter at three different locations (at the shop floor, at the laboratory and at the customer's premises) and if the values obtained are 20.255, 20.251 and 20.260 mm, then the reproducibility of the measurement can be stated as 0.009 mm (20.260 – 20.251 mm).

When making any measurement, it is normal practice to repeat the measurement in order to ensure that the data generated is repeatable. It is also important to make sure that the data generated is reasonably accurate by taking care to use measuring instruments that are calibrated.

Then, when the same measurement is made by a customer, who may either be internal or external, the data should be close to the figures generated by the manufacturer, that is to say the data should be reproducible. It is only then that the data that has been generated is considered reliable.

Readability

Is the ease with which a reader can understand a written text. In natural language, the readability of text depends on its content (the complexity of its vocabulary and syntax) and its presentation (such as typographic aspects like font size, line height, and line length). Researchers have used various factors to measure readability, such as

- Speed of perception
- Perceptibility at a distance
- Perceptibility in peripheral vision
- Visibility
- Reflex blink technique
- Rate of work (reading speed)
- Eye movements
- Fatigue in reading

Readability is more than simply legibility—which is a measure of how easily a reader can distinguish individual letters or characters from each other.

Video Content / Details of website for further learning (if any):

<https://www.youtube.com/watch?v=JVcyKqrYSAc>

Important Books/Journals for further learning including the page nos.:

Web Reference

Course Faculty

Verified by HOD