



MUTHAYAMMAL ENGINEERING COLLEGE

(An Autonomous Institution)

(Approved by AICTE, New Delhi, Accredited by NAAC & Affiliated to Anna University)
Rasipuram - 637 408, Namakkal Dist., Tamil Nadu



LECTURE HANDOUTS

L - 1

Robotics and
Automation

II / III

Course Name with Code : 19RAC02 Fluid Mechanics and Machinery

Course Faculty : Dr.T.Yuvaraj

Unit : I

Topic of Lecture: Units and dimensions

Introduction : (Maximum 5 sentences)

- Definitive or determinate quantity adopted as a standard of measurement and exchange.
- A dimension is a measure of a physical variable (without numerical values), while a unit is a way to assign a number or measurement to that dimension. For example, length is a dimension, but it is measured in units of feet (ft) or meters (m).

Prerequisite knowledge for Complete understanding and learning of Topic:

(Max. Four important topics)

- Basic units
- Dimensions

Detailed content of the Lecture:

- A measured or counted quantity has a numerical *value*. It is useful in most engineering calculations -- and essential in many -- to write both the value and the unit of each quantity appearing in an equation
- There are seven base units in the SI system:
 - the kilogram (kg), for mass.
 - the second (s), for time.
 - the kelvin (K), for temperature.
 - the ampere (A), for electric current.
 - the mole (mol), for the amount of a substance.
 - the candela (cd), for luminous intensity.
 - the meter (m), for distance.

SYSTEM OF UNITS

1. Base units, or units for the dimensions of mass, length, time, temperature, electrical current, and light intensity.
2. Multiple units, which are defined as multiples or fractions of base units such as minutes, hours, and milliseconds, all of which are defined in terms of the base unit of a second.
3. Derived units, obtained in one of two ways:
 By multiplying and dividing base or multiple units (cm², ft/min, kg · m/s², etc.). Derived units of this type are referred to as compound units.

<u>Quantity</u>	<u>Unit</u>	<u>Symbol</u>
Length	Meter (SI)	m
	Centimeter (CGS)	cm
Mass	Kilogram (SI)	kg
	Gram (CGS)	g
Moles	Gram-mole	mol or g-mole
Time	Second	s
Temperature	Kelvin	°K(or K)
Electric Current	Ampere	amp (or A)
Light Intensity	Candela	cd

- A dimension is a property that can be measured, such as length, time, mass, or temperature, or calculated by multiplying or dividing other dimensions, such as length/time (velocity), length³ (volume), or mass/length³ (density). Measurable units (as opposed to countable units) are specific values of dimensions that have been defined by convention, custom, or law, such as grams for mass, seconds for time, centimeters or feet for length, and so on
- The world as we know it has three dimensions of space—length, width and depth—and one dimension of time. But there's the mind-bending possibility that many more dimensions exist out there. According to string theory, one of the leading physics models of the last half century, the universe operates with 10 dimensions

Video Content / Details of website for further learning (if any):

<http://www.businessdictionary.com/definition/unit.html>

Important Books/Journals for further learning including the page nos.:

Bansal, R.K., "Fluid Mechanics and Hydraulics Machines", (5th edition), Laxmi publications (P) Ltd, New Delhi, 1995, Page No - 559



MUTHAYAMMAL ENGINEERING COLLEGE

(An Autonomous Institution)

(Approved by AICTE, New Delhi, Accredited by NAAC & Affiliated to Anna University)
Rasipuram - 637 408, Namakkal Dist., Tamil Nadu



LECTURE HANDOUTS

L-2

Robotics and
Automation

II / III

Course Name with Code : 19RAC02 Fluid Mechanics and Machinery

Course Faculty : Dr.T.Yuvaraj

Unit : I

Topic of Lecture: Properties of fluids, density, specific weight

Introduction : (Maximum 5 sentences)

- Any characteristic of a system is called property. It may either be intensive (mass independent) or extensive (that depends on size of system). The state of a system is described by its properties.
- The number of properties required to fix the state of the system is given by state postulates.

Prerequisite knowledge for Complete understanding and learning of Topic:
(Max. Four important topics)

- Fluid
- Types of Fluid

Detailed content of the Lecture:

Define Mass Density:

- Mass Density or Density is defined as ratio of mass of the fluid to its volume (P)
- Density of water = 1 gm/cm³ 1000 kg / m.

$$P = \frac{\text{Mass of fluid}}{\text{Volume of fluid}}$$

$$\left(P = \frac{m}{V} \right)$$

Define Specific Weight (or) Weight Density:

- It is the ratio, between weight of a fluid to its volume.

$$w = \frac{\text{Weight of fluid}}{\text{Volume of fluid}} = \left(\frac{\text{Mass of fluid}}{\text{Volume of fluid}} \right) \times g = p \times g$$

$$\omega = p \times g$$

1. Calculate density, Specific weight, and weight of 1 lt of petrol if sp. Gr. = 0.7

Given,

$$\text{Volume (v)} = 1 \text{ lt} = \frac{1}{1000} = 1 \times 1000 \text{ cm}^3 = \frac{1000}{10^6} \text{ m}^3 = 0.001 \text{ m}^3$$

$$\text{Sp. Gr} = 0.7$$

Solution

$$\text{Density } p = 3 \times 1000 \text{ kg} / \text{m}^3 = 0.7 \times 1000 = 700 \text{ kg} / \text{m}^3$$

$$\text{Sp. Wt } w = p \times g = 700 \times 9.81 \text{ N} / \text{m}^3 = 6867 \text{ N} / \text{m}^3$$

$$\text{Weight (W)} : w = \frac{W}{V} \Rightarrow \frac{W}{0.001} = 6867 \Rightarrow W = 6867 \times 0.001 = 6.867 \text{ N}$$

2. Calculate the specific weight, density and specific gravity of one litre of a liquid which weighs 7 N.

Given,

$$\text{Volume (v)} = 1 \text{ lt} = \frac{1}{1000} = 1 \times 1000 \text{ cm}^3 = \frac{1000}{10^6} \text{ m}^3 = 0.001 \text{ m}^3$$

$$\text{Weight} = 7 \text{ N}$$

Solution:

$$\text{Specific weight (w), } w = \frac{\text{Weight of fluid}}{\text{Volume of fluid}} = \left(\frac{7}{1/1000 \text{ m}^3} \right) = 7000 \text{ m}^3$$

$$\text{Density, } \rho, = \frac{W}{g} = \left(\frac{7000}{9.81} \right) = 713.5 \text{ kg} / \text{m}^3$$

$$\text{Specific gravity, (w), } w = \frac{\text{Density of Liquid}}{\text{Density of water}} = \left(\frac{713.5}{1000} \right) = 0.7135 \text{ m}^3$$

Pressure (p) : It is the normal force exerted by a fluid per unit area. More details will be available in the subsequent section (Lecture 02). In SI system the unit and dimension of pressure can be written as, N/m² and -1 -2 ML T⁻², respectively.

Video Content / Details of website for further learning (if any):

https://www.youtube.com/watch?v=xLsMJ0V_6p0

Important Books/Journals for further learning including the page nos.:

Bansal, R.K., "Fluid Mechanics and Hydraulics Machines", (5th edition), Laxmi publications (P) Ltd, New Delhi, 1995, Page No -1,2



MUTHAYAMMAL ENGINEERING COLLEGE

(An Autonomous Institution)

(Approved by AICTE, New Delhi, Accredited by NAAC & Affiliated to Anna University)
Rasipuram - 637 408, Namakkal Dist., Tamil Nadu



LECTURE HANDOUTS

L-3

Robotics and
Automation

II / III

Course Name with Code : 19RAC02 Fluid Mechanics and Machinery

Course Faculty : Dr.T.Yuvaraj

Unit : I

Topic of Lecture: Specific volume, specific gravity, temperature

Introduction : (Maximum 5 sentences)

- Specific volume is a measurement of a material related to its volume and mass. It relates to solids, liquids, and gasses, and it quantifies the amount of space a certain mass of material occupies.

**Prerequisite knowledge for Complete understanding and learning of Topic:
(Max. Four important topics)**

- Fluid Properties
- Types of Flow

Detailed content of the Lecture:

- **Specific volumes** are measured for different materials at standard temperature and pressure, which is defined as 0 degrees Celsius and 1 atm (or atmosphere). So you can refer to a table of specific volumes and figure out the specific volumes for air, water, or methane, for example. Because materials expand when temperatures go up and contract when pressure increases, the value will change if your material is at a higher temperature or under pressure.
- To calculate specific volume you need to know the volume (V) and the mass (m). Specific volume equals volume divided by mass. Typically, volume is measured in cubic meters (m^3), and mass is measured in kilograms. Specific volume is then calculated as volume divided by mass.
- **Specific gravity.** The ratio of the mass of a solid or liquid to the mass of an equal volume of distilled water at 4°C (39°F) or of a gas to an equal volume of air or hydrogen under prescribed conditions of temperature and pressure.
- Specific gravity is an important property of fluids being related to density and viscosity.

Knowing the specific gravity will allow determination of a fluid's characteristics compared to a standard, usually water, at a specified temperature. It has the SI unit kg m^{-3} or Kg/m^{-3} and is an absolute quantity. The specific gravity of an object is the ratio between the density of an object to a reference liquid. Usually, our reference liquid is water, which has a density of 1 g/mL or 1 g/cm^3 .

1. Calculate the sp wt, density and sp gravity of 1 liter of liquid which weighs 7 N.

Solution:

$$\text{Given } V = 1 \text{ litre} = \frac{1}{1000} \text{ m}^3, \quad W = 7 \text{ N} \quad \left(\begin{array}{l} 1 \text{lt} = \frac{1}{1000} \text{m}^3 \\ 1000 \text{lt} = 1 \text{m}^3 \end{array} \right)$$

$$1. \text{ Sp. Weight (w)} = \frac{\text{weight}}{\text{volume}} = \frac{7 \text{ N}}{\left(\frac{1}{1000}\right) \text{m}^3} = 7000 \text{ N / m}^3$$

$$2. \text{ Density (p)} = \frac{w}{g} = \frac{7000 \text{ N}}{9.81 \text{ m/s}^2} \text{ kg / m}^3 = 713.5 \text{ Kg / m}^3$$

$$3. \text{ Sp. Gravity} = \frac{\text{Density of liquid}}{\text{Density of water}} = \frac{713.5}{1000} \text{ (Density of water} = 1000 \text{ kg / m}^3 \text{), } g = 9.81 \text{ m / s}^2 \\ = 0.7135$$

- **Temperature** is a physical property of matter that quantitatively expresses hot and cold. It is the manifestation of thermal energy, present in all matter, which is the source of the occurrence of heat, a flow of energy, when a body is in contact with another that is colder.
- Temperature is measured with a thermometer. Thermometers are calibrated in various temperature scales that historically have used various reference points and thermometric substances for definition. The most common scales are the Celsius scale (formerly called centigrade), denoted °C, the Fahrenheit scale (denoted °F), and the Kelvin scale (denoted K), the latter of which is predominantly used for scientific purposes by conventions of the International System of Units (SI).

Video Content / Details of website for further learning (if any):

https://www.youtube.com/watch?v=xLsMJ0V_6p0

Important Books/Journals for further learning including the page nos.:

Bansal, R.K., "Fluid Mechanics and Hydraulics Machines", (5th edition), Laxmi publications (P) Ltd, New Delhi, 1995, Page No -1,2



MUTHAYAMMAL ENGINEERING COLLEGE

(An Autonomous Institution)

(Approved by AICTE, New Delhi, Accredited by NAAC & Affiliated to Anna University)
Rasipuram - 637 408, Namakkal Dist., Tamil Nadu



LECTURE HANDOUTS

L-4

Robotics and
Automation

II / III

Course Name with Code : 19RAC02 Fluid Mechanics and Machinery

Course Faculty : Dr.T.Yuvaraj

Unit : I

Topic of Lecture: viscosity, compressibility

Introduction : (Maximum 5 sentences)

- A quantity expressing the magnitude of internal friction in a fluid, as measured by the force per unit area resisting uniform flow.
- Compressibility is the capacity of something to be flattened or reduced in size by pressure.

**Prerequisite knowledge for Complete understanding and learning of Topic:
(Max. Four important topics)**

- Internal friction
- Shear stress
- Density

Detailed content of the Lecture:

- Viscosity is defined as the property of fluid which offers resistance to the movement of one layer of fluid over another adjacent layer of fluid.
- When two layers move one over the other at different velocities, say U and V+ du, the viscosity together with relative velocity causes shear stress acting between the fluid layer. The top layer causes a shear stress on the adjacent lower layer while the lower layer causes a shear stress on the adjacent top layer.

Shear stress

$$\tau \propto \frac{du}{dy}$$

- This shear stress is proportional to the rate of change of velocity constant of proportionality.

$$\tau = \mu \frac{du}{dy}$$

(or)

$\mu \Rightarrow$ Coefficient of dynamic viscosity (or) only viscosity

1. Dynamic Viscosity
2. Kinematic Viscosity

Newton's Law of Viscosity (Dynamic viscosity):

- It states that the shear stress (τ) on a fluid element layer is directly proportional to the rate of shear strain. The constant of proportionality is called the co-efficient of viscosity

$$\tau = \mu \frac{du}{dy}$$

Kinematic Viscosity:

- It is defined as the ratio between the dynamic viscosity and density of fluid.

$$\text{Represented as } \nu \text{ (nu). } \nu = \frac{\text{Viscosity}}{\text{Density}} = \frac{\mu}{\rho}$$

SI and MKS unit: m^2 / sec .

CGS: cm^2 / S . (Kinematic also known STROKE)

$$1 \text{ Stoke} = \frac{Cm^2}{S} = \left(\frac{1}{100}\right)^2 \frac{m^2}{S} = 10^{-4} m^2 / s.$$

Centistokes means $= \frac{1}{100} \text{ stoke}$

Find the kinematics viscosity of an oil having density 981 kg/m. The shear stress at a point in oil is 0.2452 N/m² and velocity gradient at that point is 0.2 /sec.

Mass density $\rho = 981 \text{ kg/m}^3$, Shear stress $\tau = 0.2452 \text{ N} / m^2$

Velocity gradient $\frac{du}{dy} = 0.2$

$$\tau = \mu \frac{du}{dy} \Rightarrow 0.2452 = \mu \times 0.2 \Rightarrow \mu = \frac{0.2452}{0.2} = 1.226 \text{Ns}.$$

$$\nu = \frac{\mu}{\rho} = \frac{1.226}{981} = 0.125 \times 10^{-2} m^2 / s. = 0.125 \times 10^{-2} \times 10^4 cm^2 / S \text{ (} cm^2 / s = \text{stoke)}$$

$$\nu = 0.125 \times 10^2 cm^2 / s = 12.5 cm^2 / s = 12.5 \text{stoke}.$$

Determine the sp gravity of a fluid having viscosity 0.05 poise and Kinematic viscosity 0.035 stokes.

$$\text{Specific gravity of liquid} = \frac{\text{Density of liquid}}{\text{Density of water}} = \frac{1428.5}{1000} = 1.428 = 1.43$$

$$\mu = 0.05 \text{poise} = \frac{0.05}{10} \text{Ns} / m^2$$

$$0.035 \times 10^{-4} = \frac{0.05}{10} \times \frac{1}{\rho} \Rightarrow \rho = 1428.5 \text{kg} / m^3$$

$$\nu = \frac{\mu}{\rho}$$

Video Content / Details of website for further learning (if any):

<https://www.youtube.com/watch?v=eAMbdstQNJA>

Important Books/Journals for further learning including the page nos.:

Bansal, R.K., "Fluid Mechanics and Hydraulics Machines", (5th edition), Laxmi publications (P) Ltd, New Delhi, 1995, Page No – 3 -5.



MUTHAYAMMAL ENGINEERING COLLEGE

(An Autonomous Institution)

(Approved by AICTE, New Delhi, Accredited by NAAC & Affiliated to Anna University)
Rasipuram - 637 408, Namakkal Dist., Tamil Nadu



LECTURE HANDOUTS

L-5

Robotics and
Automation

II / III

Course Name with Code : 19RAC02 Fluid Mechanics and Machinery

Course Faculty : Dr.T.Yuvaraj

Unit : I

Topic of Lecture: vapour pressure, capillary and surface tension

Introduction : (Maximum 5 sentences)

- Vapour pressure is the pressure of a vapour in contact with its liquid or solid form.
- The tendency of a liquid in a capillary tube or absorbent material to rise or fall as a result of surface tension.

Prerequisite knowledge for Complete understanding and learning of Topic: (Max. Four important topics)

- Tensile Force
- Rise and Fall of Liquid

Detailed content of the Lecture:

Vapor pressure

Vapor pressure is the pressure caused by the evaporation of liquids. Three common factors that influence vapor pressure are surface area, intermolecular forces and temperature. The vapor pressure of a molecule differs at different temperatures.

Surface Tension.

Surface tension is defined as the tensile force acting on the surface of a liquid in contact with a gas or on the surface between two immiscible liquids such that the contact surface behaves like a membrane under tension. In MKS unit, kgf/m, SI \Rightarrow N / m

Capillarity:

Capillarity is defined as a phenomenon of rise or fall of a liquid surface in a small tube relative to adjacent general level of liquid when the tube is held vertically in the liquid. The rise of liquid surface is known as capillary rise while the fall of the liquid surface is known as capillary depression.

Expression for capillary Rise or fall $h = \frac{4\sigma \cos\theta}{\rho \times g \times d}$

Where,

h = height of depression in tube.

d = diameter of the

σ = surface tension

ρ = density of the liquid.

θ = Angle of contact between liquid and gas.

Capillary rise in the glass tube is not to exceed 0.2 mm of water. Determine its minimum size, given that surface tension of water in contact with air = 0.0725 N/m

Capillary rise $\Rightarrow h = 0.2 \text{ mm} = 0.2 \times 10^{-3}$

Surface tension $\sigma = 0.0725 \text{ N/m}$

Dia of tube = d . Angel θ for water = 0

Density ρ for water = 1000 kg/m^3

$$h = \frac{4\sigma}{\rho \times g \times d} \Rightarrow 0.2 \times 10^{-3} = \frac{4 \times 0.0725}{1000 \times 9.81 \times d}$$

$$d = \frac{4 \times 0.0725}{1000 \times 9.81 \times 0.2 \times 10^{-3}} = 0.148 \text{ m} = 14.8 \text{ cm}$$

Minimum ϕ of the tube = 14.8 cm.

Find out the minimum size of glass tube that can be used to measure water level o if the capillary rise in the tube is to be restricted to 2mm. Consider surface tension of water in contact with air as 0.073575 N/m.

$h = 2.0 \text{ mm} = 2.0 \times 10^{-3} \text{ m}$, dia = d density of water = 1000 kg/m^3

$\sigma = 0.073575 \text{ N/m}$ angle $\theta = 0$

$$h = \frac{4\sigma}{\rho \times g \times d} \Rightarrow 2.0 \times 10^{-3} = \frac{4 \times 0.073575}{1000 \times 9.81 \times d}, \quad d = 0.015 \text{ m} = 1.5 \text{ cm.}$$

Video Content / Details of website for further learning (if any):

<https://www.youtube.com/watch?v=PP9mn-X9i2Q>

Important Books/Journals for further learning including the page nos.:

Bansal, R.K., "Fluid Mechanics and Hydraulics Machines", (5th edition), Laxmi publications (P) Ltd, New Delhi, 1995, Page No -23



MUTHAYAMMAL ENGINEERING COLLEGE

(An Autonomous Institution)

(Approved by AICTE, New Delhi, Accredited by NAAC & Affiliated to Anna University)
Rasipuram - 637 408, Namakkal Dist., Tamil Nadu



LECTURE HANDOUTS

L-6

Robotics and
Automation

II / III

Course Name with Code : 19RAC02 Fluid Mechanics and Machinery

Course Faculty : Dr.T.Yuvaraj

Unit : I

Topic of Lecture: Application of control volume to continuity equation

Introduction : (Maximum 5 sentences)

- The continuity equation reflects the fact that mass is conserved in any non-nuclear continuum mechanics analysis.
- The equation is developed by adding up the rate at which mass is flowing in and out of a control volume, and setting the net in-flow equal to the rate of change of mass within it.

Prerequisite knowledge for Complete understanding and learning of Topic: (Max. Four important topics)

- conservation of mass
- Density
- Fluid Properties

Detailed content of the Lecture:

There are three basic types of control volumes. They are fixed non-deforming control volumes, moving control volumes, and deforming control volumes.

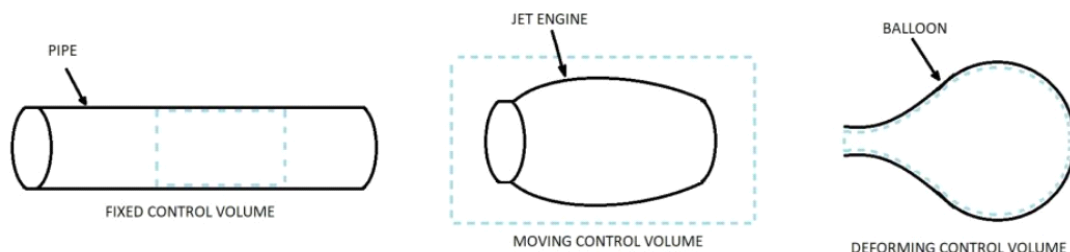

CONTINUITY EQUATION:

The equation based on the principle of conservation of mass is called continuity equation. Thus for a fluid flowing through the pipe at all the cross-section, the quantity of fluid per second is constant. Consider two cross-sections of a pipe as shown in figure.

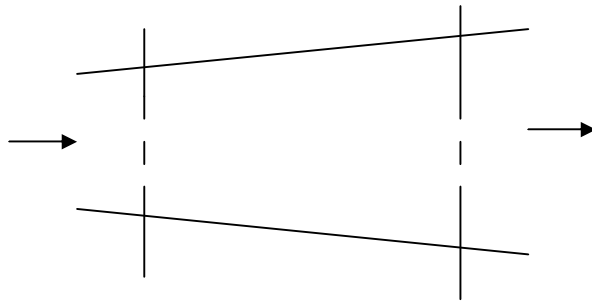

Fig: 1.1 Continuity Equation

Let V_1 = Average velocity at cross-section at 1-1

ρ_1 = Density at section 1-1

A_1 = Area of pipe at section 1-1

And V_2, ρ_2, A_2 are corresponding values at section 2-2

Then rate of flow at section 1-1 = $V_1 \rho_1 A_1$

Rate of flow at section 2-2 = $V_2 \rho_2 A_2$

According to law of conservation of mass

Rate of flow at section 1-1 = Rate of flow at section 2-2

$$\rho_1 A_1 V_1 = \rho_2 A_2 V_2 \dots\dots\dots(1)$$

The above equation is applicable to the compressible as well as incompressible fluids is called Continuity Equation. If the fluid is incompressible, then $\rho_1 = \rho_2$ and continuity equation (1) reduces to $A_1 V_1 = A_2 V_2$

The diameters of a pipe at the sections 1 and 2 are 10cm and 15cm respectively. Find the discharge through the pipe if the velocity of water flowing through the pipe at section 1 is 5m/s. Determine the velocity at section 2.

Video Content / Details of website for further learning (if any):

<https://www.youtube.com/watch?v=ydgJvnm24ks>

Important Books/Journals for further learning including the page nos.:

Bansal, R.K., "Fluid Mechanics and Hydraulics Machines", (5th edition), Laxmi publications (P) Ltd, New Delhi, 1995, Page No -165



MUTHAYAMMAL ENGINEERING COLLEGE

(An Autonomous Institution)

(Approved by AICTE, New Delhi, Accredited by NAAC & Affiliated to Anna University)
Rasipuram - 637 408, Namakkal Dist., Tamil Nadu



LECTURE HANDOUTS

L-7

Robotics and
Automation

II / III

Course Name with Code : 19RAC02 Fluid Mechanics and Machinery

Course Faculty : Dr.T.Yuvaraj

Unit : I

Topic of Lecture: Application of control volume to continuity equation

Introduction : (Maximum 5 sentences)

- The continuity equation reflects the fact that mass is conserved in any non-nuclear continuum mechanics analysis.
- The equation is developed by adding up the rate at which mass is flowing in and out of a control volume, and setting the net in-flow equal to the rate of change of mass within it.

Prerequisite knowledge for Complete understanding and learning of Topic: (Max. Four important topics)

- conservation of mass
- Density
- Fluid Properties

Detailed content of the Lecture:

1. The diameters of a pipe at the sections 1 and 2 are 10 cm and 15 cm respectively. Find the discharge through the pipe if the velocity of water flowing through the pipe section 1 is 5 m/s. determine also the velocity at section 2.

Solution

At section 1. $D_1 = 10 \text{ cm} = 0.1 \text{ m}.$

$$A_1 = (\pi / 4) \times D_1^2 = (\pi / 4) \times (0.1)^2 = 0.007854 \text{ m}^2.$$

$$V_1 = 5 \text{ m/s}.$$

At section 2. $D_2 = 15 \text{ cm} = 0.15 \text{ m}.$

$$A_2 = (\pi / 4) \times (0.15)^2 = 0.01767 \text{ m}^2.$$

Discharge through pipe is given by equation

$$Q = A_1 \times V_1$$

$$= 0.007544 \times 5 = 0.03927 \text{ m}^3/\text{s}.$$

$$V_2 = (A_1 V_1 / A_2)$$

$$= (0.007854 / 0.01767) \times 5 = 2.22 \text{ m/s.}$$

2. Water flows through a pipe AB 1.2m diameter at 3 m/s and then passes through a pipe BC 1.5 m diameter at C, the pipe branches. Branch CD is 0.8m in diameter and carries one third of the flow in AB. The flow velocity in branch CE is 2.5 m/s. find the volume rate of flow in AB, the velocity in BC, the velocity in CD and the diameter of CE.

Solution

Diameter of Pipe AB,	$D_{AB} = 1.2 \text{ m.}$
Velocity of flow through AB	$V_{AB} = 3.0 \text{ m/s.}$
Dia. of Pipe BC,	$D_{BC} = 1.5\text{m.}$
Dia. of Branched pipe CD,	$D_{CD} = 0.8\text{m.}$
Velocity of flow in pipe CE,	$V_{CE} = 2.5 \text{ m/s.}$
Let the rate of flow in pipe	$AB = Q \text{ m}^3/\text{s.}$
Velocity of flow in pipe	$BC = V_{BC} \text{ m}^3/\text{s.}$
Velocity of flow in pipe	$CD = V_{CD} \text{ m}^3/\text{s.}$

Diameter of pipe	$CE = D_{CE}$
Then flow rate through	$CD = Q / 3$
And flow rate through	$CE = Q - Q/3 = 2Q/3$

(i). Now the flow rate through AB = $Q = V_{AB} \times \text{Area of AB}$

$$= 3 \times (\pi / 4) \times (D_{AB})^2 = 3 \times (\pi / 4) \times (1.2)^2$$

$$= 3.393 \text{ m}^3/\text{s.}$$

(ii). Applying the continuity equation to pipe AB and pipe BC,

$$V_{AB} \times \text{Area of pipe AB} = V_{BC} \times \text{Area of Pipe BC}$$

$$3 \times (\pi / 4) \times (D_{AB})^2 = V_{BC} \times (\pi / 4) \times (D_{BC})^2$$

$$V_{BC} = (3 \times 1.2^2) / 1.5^2 = 1.92 \text{ m/s.}$$

(iii). The flow rate through pipe

$$CD = Q_1 = Q/3 = 3.393 / 3 = 1.131 \text{ m}^3/\text{s.}$$

$$Q_1 = V_{CD} \times \text{Area of pipe } C_D \times (\pi / 4) \times (D_{CD})^2$$

$$1.131 = V_{CD} \times (\pi / 4) \times (0.8)^2$$

$$V_{CD} = 1.131 / 0.5026 = 2.25 \text{ m/s}$$

Video Content / Details of website for further learning (if any):

<https://www.youtube.com/watch?v=ycgJvnm24ks>

Important Books/Journals for further learning including the page nos.:

Bansal, R.K., "Fluid Mechanics and Hydraulics Machines", (5th edition), Laxmi publications (P) Ltd, New Delhi, 1995, Page No -167



MUTHAYAMMAL ENGINEERING COLLEGE

(An Autonomous Institution)

(Approved by AICTE, New Delhi, Accredited by NAAC & Affiliated to Anna University)
Rasipuram - 637 408, Namakkal Dist., Tamil Nadu



LECTURE HANDOUTS

L-8

Robotics and Automation

II / III

Course Name with Code : 19RAC02 Fluid Mechanics and Machinery

Course Faculty : Dr.T.Yuvaraj

Unit : I

Topic of Lecture: Energy equation

Introduction : (Maximum 5 sentences)

- The energy equation is an extension of the energy principle which states that energy cannot be created or destroyed but can only be converted to other forms

Prerequisite knowledge for Complete understanding and learning of Topic:
(Max. Four important topics)

- Energy principle
- Euler's Equation

Detailed content of the Lecture:

- This is equation of motion in which the forces due to gravity and pressure are taken into consideration. This is derived by considering the motion of a fluid element along a stream-line as:
- Consider a stream-line in which flow is taking place in S-direction as shown in figure. Consider a cylindrical element of cross-section dA and length ds . The forces acting on the cylindrical element are:
 1. Pressure force pdA in the direction of flow.
 2. Pressure force $\left(p + \frac{\partial p}{\partial s} ds \right) dA$ opposite to the direction of flow.
 3. Weight of element $\rho g dA ds$.
- Let θ is the angle between the direction of flow and the line of action of the weight of element. The resultant force on the fluid element in the direction of S must be equal to the mass of fluid element \times acceleration in the S direction.
- $pdA - \left(p + \frac{\partial p}{\partial s} ds \right) dA - \rho g dA ds \cos \theta = \rho dA ds \times a_s$ -----(1)

Where a_s is the acceleration in the direction of S.

Now $a_s = \frac{dv}{dt}$, where v is a function of s and t .

$$= \frac{\partial v}{\partial s} \frac{ds}{dt} + \frac{\partial v}{\partial t} = \frac{v \partial v}{\partial s} + \frac{\partial v}{\partial t} \quad \left\{ \frac{ds}{dt} = v \right\}$$

$$a_s = \frac{v \partial v}{\partial s}$$

Substituting the value of a_s in equation (1) and simplifying the equation, we get

$$-\frac{\partial p}{\partial s} ds dA - \rho g dA ds \cos \theta = \rho dA ds \times \frac{v \partial v}{\partial s}$$

Dividing by $\rho ds dA$, $-\frac{\partial p}{\rho \partial s} - g \cos \theta = \frac{v \partial v}{\partial s}$

$$\frac{\partial p}{\rho \partial s} + g \cos \theta + \frac{v \partial v}{\partial s} = 0, \text{ we know that } \cos \theta = \frac{dz}{ds}$$

$$\frac{1}{\rho} \frac{\partial p}{\partial s} + g \frac{dz}{ds} + \frac{v \partial v}{\partial s} = 0 \quad \text{or} \quad \frac{\partial p}{\rho} + g dz + v dv = 0$$

$$\frac{\partial p}{\rho} + g dz + v dv = 0 \text{ -----(2)}$$

The above equation is known as Euler's equation of motion.

Bernoulli's equation is obtained by integrating the above Euler's equation of motion.

$$\int \frac{\partial p}{\rho} + \int g dz + \int v dv = \text{const}$$

If the flow is incompressible, ρ is a constant and

$$\frac{p}{\rho} + gz + \frac{v^2}{2} = \text{const}$$

$$\frac{p}{\rho g} + z + \frac{v^2}{2g} = \text{const}$$

$$\frac{p}{\rho g} + \frac{v^2}{2g} + z = \text{const} \text{ -----(3)}$$

The above equation is known as Bernoulli's equation.

$\frac{p}{\rho g}$ = pressure energy per unit weight of fluid or pressure Head

$\frac{v^2}{2g}$ = kinetic energy per unit weight or kinetic Head

z = potential energy per unit weight or potential Head

ASSUMPTIONS:

The following are the assumptions made in the derivation of Bernoulli's equation:

- (i) The fluid is ideal, i.e. viscosity is zero
- (ii) The flow is steady
- (iii) The flow is incompressible
- (iv) The flow is irrotational

Video Content / Details of website for further learning (if any):

<https://www.youtube.com/watch?v=k4zIxfUeNbE>

Important Books/Journals for further learning including the page nos.:

Bansal, R.K., "Fluid Mechanics and Hydraulics Machines", (5th edition), Laxmi publications (P) Ltd, New Delhi, 1995, Page No -261



MUTHAYAMMAL ENGINEERING COLLEGE

(An Autonomous Institution)

(Approved by AICTE, New Delhi, Accredited by NAAC & Affiliated to Anna University)
Rasipuram - 637 408, Namakkal Dist., Tamil Nadu



LECTURE HANDOUTS

L-9

Robotics and
Automation

II / III

Course Name with Code : 19RAC02 Fluid Mechanics and Machinery

Course Faculty : Dr.T.Yuvaraj

Unit : I

Topic of Lecture: Momentum equation and moment of momentum equation

Introduction : (Maximum 5 sentences)

- It's a term that describes a relationship between the mass and velocity of an object, and we can see this when it is written in equation form, $p = mv$, where p is momentum, m is mass in kg and v is velocity in m/s.
- Because momentum is a vector quantity, this means it has both magnitude and direction.

Prerequisite knowledge for Complete understanding and learning of Topic: (Max. Four important topics)

- Velocity
- Momentum

Detailed content of the Lecture:

- The momentum equation is a statement of Newton's Second Law and relates the sum of the forces acting on an element of fluid to its acceleration or rate of change of momentum. You will probably recognise the equation $F = ma$ which is used in the analysis of solid mechanics to relate applied force to acceleration.
- Application of the Momentum Equation. The momentum equation is used to determine the resultant force exerted on the boundaries of a flow passage by a stream of flowing fluid as the flow changes its direction or the magnitude of velocity or both. (3) Fluid flow through stationary and moving plates or vanes.
- For example, a bowling ball (large mass) moving very slowly (low velocity) can have the same momentum as a baseball (small mass) that is thrown fast (high velocity). A bullet is another example where the momentum is very-very high, due to the extraordinary velocity.
- The unit of momentum is the product of the units of mass and velocity. In SI units, if the mass is in kilograms and the velocity is in meters per second then the momentum is

in kilogram meters per second (kg·m/s).

1. The water is flowing through a pipe having diameters 20 cm and 10 cm at sections 1 and 2 respectively. The rate of flow through pipe is 35 lit/sec. the section 1 is 6m above datum. If the pressure at section 2 is 4m above the datum. If the pressure at section 1 is 39.24 N/cm², find the intensity of pressure at section 2.

Solution

At section 1, $D_1 = 20 \text{ cm} = 0.2\text{m}$

$$A_1 = \frac{\Pi}{4}(0.2)^2 = 0.314\text{m}^2.$$

$$P_1 = 39.24 \text{ N/cm}^2 = 39.24 \times 10^4 \text{ N/m}^2.$$

$$Z_1 = 6.0\text{m}$$

At section 2, $D_2 = 0.10\text{m}$

$$A_2 = \frac{\Pi}{4}(0.1)^2 = 0.0785\text{m}^2.$$

$$P_2 = ?$$

$$Z_2 = 4.0\text{m}$$

Rate of flow $Q = 35 \text{ lit/sec} = 35/1000 = 0.035\text{m}^3/\text{s}$

$$Q = A_1V_1 = A_2V_2$$

$$V_1 = Q / A_1 = 0.035 / 0.314 = 1.114 \text{ m/s}$$

$$V_2 = Q / A_2 = 0.035 / 0.0785 = 4.456 \text{ m/s.}$$

Applying Bernoulli's Equations at sections at 1 and 2, we get

$$\frac{p_1}{\rho g} + \frac{v_1^2}{2g} + z_1 = \frac{p_2}{\rho g} + \frac{v_2^2}{2g} + z_2$$

$$(39.24 \times 10^4 / 1000 \times 9.81) + ((1.114)^2 / 2 \times 9.81) + 6.0$$

$$= (p_2 / 1000 \times 9.81) + ((4.456)^2 / 2 \times 9.81) + 4.0$$

$$40 + 0.063 + 6.0 = (p_2 / 9810) + 1.012 + 4.0$$

$$46.063 = (p_2 / 9810) + 5.012$$

$$(p_2 / 9810) = 46.063 - 5.012 = 41.051$$

$$p_2 = (41.051 \times 9810 / 10^4) = 40.27 \text{ N/cm}^2$$

Video Content / Details of website for further learning (if any):

<https://www.youtube.com/watch?v=l4xjqsldi7U>

Important Books/Journals for further learning including the page nos.:

Bansal, R.K., "Fluid Mechanics and Hydraulics Machines", (5th edition), Laxmi publications (P) Ltd, New Delhi, 1995, Page No -288



MUTHAYAMMAL ENGINEERING COLLEGE

(An Autonomous Institution)

(Approved by AICTE, New Delhi, Accredited by NAAC & Affiliated to Anna University)
Rasipuram - 637 408, Namakkal Dist., Tamil Nadu



LECTURE HANDOUTS

L-10

Robotics and
Automation

II / III

Course Name with Code : 19RAC02 Fluid Mechanics and Machinery

Course Faculty : Dr.T.Yuvaraj

Unit : II

Topic of Lecture: Laminar flow through circular conduits and circular annuli

Introduction : (Maximum 5 sentences)

- The assumptions of the equation are that the fluid is incompressible and Newtonian; the flow is laminar through a pipe of constant circular cross-section that is substantially longer than its diameter; and there is no acceleration of fluid in the pipe

Prerequisite knowledge for Complete understanding and learning of Topic: (Max. Four important topics)

- Laminar flow
- Compressible fluids
- Path flow

Detailed content of the Lecture:

- For the flow of viscous fluid through circular pipe, the velocity distribution across a section, the ratio of maximum velocity to average velocity, the shear stress distribution and drop of pressure for a given length is to be determined. The flow through circular pipe will be viscous or laminar, if the Reynolds's number is less than 2000. The expression for Reynolds's number is given by

$$R_e = \frac{\rho v d}{\mu}$$

Where,

- ρ = Density of fluid flowing through pipe,

V = Average velocity of fluid,
D = Diameter of pipe and,
 μ = Viscosity of fluid

- Consider a horizontal pipe of radius R. The viscous fluid is flowing from left to right in the pipe as shown in figure. Consider a fluid element of radius r, sliding in a cylindrical fluid element of radius (r+dr). Let the length of fluid element be Δx . If 'p' is the intensity of pressure on the

acting on the fluid element are:

1. The pressure force, $p \times \pi r^2$ on face AB

2. The pressure force $\left(p + \frac{\partial p}{\partial x} \Delta x\right) \cdot \pi r^2$ on face CD

3. The shear force, $\tau \times 2\pi r \Delta x$ on the surface of fluid element. As there is no acceleration, hence the summation of all forces in the direction of flow must be zero.

$$p \pi r^2 - \left(p + \frac{\partial p}{\partial x} \Delta x\right) \cdot \pi r^2 - \tau \times 2\pi r \Delta x = 0$$

$$-\frac{\partial p}{\partial x} \Delta x \pi r^2 - \tau \times 2\pi r \Delta x = 0$$

$$-\frac{\partial p}{\partial x} r - 2\tau = 0$$

$$\tau = -\frac{\partial p}{\partial x} \frac{r}{2} \text{ ----- (1)}$$

The shear stress τ across a section varies with 'r' as $\frac{\partial p}{\partial x}$ across a section is constant. Hence shear stress across a section is linear as shown in figure.

Velocity Distribution:

To obtain the velocity distribution across a section, the value of shear stress $\tau = \mu \frac{\partial u}{\partial y}$ is substituted in equation (1)

But in the relation $\tau = \mu \frac{\partial u}{\partial y}$, y is measured from the pipe wall. Hence

$$y = R - r \quad \text{and} \quad dy = -dr$$

$$\tau = \mu \frac{\partial u}{-\partial r} = -\mu \frac{du}{dr}$$

substituting this value in equation (1)

$$-\mu \frac{du}{dr} = -\frac{\partial p}{\partial x} \frac{r}{2}$$

$$\frac{du}{dr} = \frac{1}{2\mu} \frac{\partial p}{\partial x} r$$

Integrating the equation w.r.t 'r' we get

$$u = \frac{1}{4\mu} \frac{\partial p}{\partial x} r^2 + C \text{ ----- (2)}$$

Where, C is the constant of integration and its value is obtained from the boundary condition that at $r=R, u=0$

$$0 = \frac{1}{4\mu} \frac{\partial p}{\partial x} R^2 + C$$

$$C = -\frac{1}{4\mu} \frac{\partial p}{\partial x} R^2$$

Substituting this value of C in equation (2), we get

$$u = \frac{1}{4\mu} \frac{\partial p}{\partial x} r^2 - \frac{1}{4\mu} \frac{\partial p}{\partial x} R^2$$

$$u = \frac{1}{4\mu} \frac{\partial p}{\partial x} [R^2 - r^2] \text{ ----- (3)}$$

In equation (3) values of μ , $\frac{\partial p}{\partial x}$ and r are constant, which means the velocity u, varies with the square

of r . Thus the equation (3) is an equation of parabola. This shows that the velocity distribution across the section of a pipe is parabolic. This velocity distribution is shown in fig.

Ratio of Maximum velocity to average velocity:

The velocity is maximum, when $r = 0$ in equation (3). Thus maximum velocity, U_{max} is obtained as

$$U_{max} = -\frac{1}{4\mu} \frac{\partial p}{\partial x} R^2 \text{ -----(4)}$$

The average velocity, \bar{u} , is obtained by dividing the discharge of the fluid across the section by the area of the pipe (πR^2). The discharge (Q) across the section is obtained by considering the through a ring element of radius r and thickness dr as shown in fig(b). The fluid flowing per second through the elementary ring

$$\begin{aligned} dQ &= \text{velocity at a radius } r \times \text{area of ring element} \\ &= u \times 2\pi r dr \\ &= -\frac{1}{4\mu} \frac{\partial p}{\partial x} [R^2 - r^2] \times 2\pi r dr \end{aligned}$$

$$\begin{aligned} Q &= \int_0^R dQ = \int_0^R -\frac{1}{4\mu} \frac{\partial p}{\partial x} [R^2 - r^2] \times 2\pi r dr \\ &= \frac{1}{4\mu} \left(-\frac{\partial p}{\partial x} \right) \times 2\pi \int_0^R (R^2 - r^2) r dr \\ &= \frac{1}{4\mu} \left(-\frac{\partial p}{\partial x} \right) \times 2\pi \left[\frac{R^4}{4} \right] = \frac{\pi}{8\mu} \left(-\frac{\partial p}{\partial x} \right) \times 2\pi R^4 \end{aligned}$$

$$\text{Average velocity, } \bar{u} = \frac{Q}{\text{Area}} = \frac{\frac{\pi}{8\mu} \left(-\frac{\partial p}{\partial x} \right) R^4}{\pi R^2}$$

$$\bar{u} = \frac{1}{8\mu} \left(-\frac{\partial p}{\partial x} \right) R^2 \text{ ----- (5)}$$

Dividing equation (4) by equation (5)

$$\frac{U_{max}}{\bar{u}} = \frac{\frac{1}{4\mu} \frac{\partial p}{\partial x} R^2}{\frac{1}{8\mu} \left(-\frac{\partial p}{\partial x} \right) R^2} = 2.0$$

Ratio of maximum velocity to average velocity = 2.0

Video Content / Details of website for further learning (if any):

https://www.youtube.com/watch?v=3ZdEr_UeTXM

Important Books/Journals for further learning including the page nos.:

Bansal, R.K., "Fluid Mechanics and Hydraulics Machines", (5th edition), Laxmi publications (P) Ltd, New Delhi, 1995, Page No -164



MUTHAYAMMAL ENGINEERING COLLEGE

(An Autonomous Institution)

(Approved by AICTE, New Delhi, Accredited by NAAC & Affiliated to Anna University)
Rasipuram - 637 408, Namakkal Dist., Tamil Nadu



LECTURE HANDOUTS

L-11

Robotics and
Automation

II / III

Course Name with Code : 19RAC02 Fluid Mechanics and Machinery

Course Faculty : Dr.T.Yuvaraj

Unit : II

Topic of Lecture: Boundary layer concepts

Introduction : (Maximum 5 sentences)

- Boundary layer, in fluid mechanics, thin layer of a flowing gas or liquid in contact with a surface such as that of an airplane wing or of the inside of a pipe.
- The flow in such boundary layers is generally laminar at the leading or upstream portion and turbulent in the trailing or downstream portion.

**Prerequisite knowledge for Complete understanding and learning of Topic:
(Max. Four important topics)**

- Boundary layer
- Laminar flow
- Turbulent flow

Detailed content of the Lecture:

Boundary layer:

When a real fluid flow passed a solid boundary, fluid layer is adhered to the solid boundary. Due to adhesion fluid undergoes retardation thereby developing a small region in the immediate vicinity of the boundary. This region is known as boundary layer.

Boundary layer growth:

At subsequent points downstream of the leading edge, the boundary layer region increases because the retarded fluid is further retarded. This is referred as growth of boundary layer.

Classification of boundary layer:

- (i) Laminar boundary layer
- (ii) Transition zone
- (iii) Turbulent boundary layer.

Laminar boundary layer:

Near the leading edge of the surface of the plate the thickness of boundary layer is small and

velocity profile is parabolic.

Transition zone:

After laminar zone, the laminar boundary layer becomes unstable and the fluid motion transformed to turbulent boundary layer. This short length over which the changes taking place is called as transition zone.

Turbulent boundary:

Further downstream of transition zone, the boundary layer is turbulent and continuous to grow in thickness. This layer of boundary is called turbulent boundary layer.

Laminar sub Layer:

In the turbulent boundary layer zone, adjacent to the solid surface of the plate the velocity variation is influenced by viscous effects. Due to very small thickness, the velocity distribution is almost linear. This region is known as laminar sub layer.

Boundary layer Thickness:

It is defined as the distance from the solid boundary measured in y-direction to the point, where the velocity of fluid is approximately equal to 0.99 times the free stream velocity (U) of the fluid. It is denoted by d.

Types of boundary layer thickness:

Displacement thickness (d^*),

Momentum thickness (θ),

Energy thickness (d^{**}).

Displacement thickness:

The displacement thickness (d) is defined as the distance by which the boundary should be displaced to compensate for the reduction in flow rate on account of boundary layer formation.

$$d^* = \int [1 - (u/U)] dy$$

Momentum thickness:

The momentum thickness (θ) is defined as the distance by which the boundary should be displaced to compensate for the reduction in momentum of the flowing fluid on account of boundary layer formation.

$$\theta = \int [(u/U) - (u/U)^2] dy$$

Energy thickness:

The energy thickness (d^{**}) is defined as the distance by which the boundary should be displaced to compensate for the reduction in kinetic energy of the flowing fluid on account of boundary layer formation.

$$d^{**} = \int [(u/U) - (u/U)^3] dy$$

Video Content / Details of website for further learning (if any):

<https://www.youtube.com/watch?v=qOrhmKzwcFA>

Important Books/Journals for further learning including the page nos.:

Bansal, R.K., "Fluid Mechanics and Hydraulics Machines", (5th edition), Laxmi publications (P) Ltd, New Delhi, 1995, Page No -611



MUTHAYAMMAL ENGINEERING COLLEGE

(An Autonomous Institution)

(Approved by AICTE, New Delhi, Accredited by NAAC & Affiliated to Anna University)
Rasipuram - 637 408, Namakkal Dist., Tamil Nadu



LECTURE HANDOUTS

L-12

Robotics and
Automation

II / III

Course Name with Code : 19RAC02 Fluid Mechanics and Machinery

Course Faculty : Dr.T.Yuvaraj

Unit : II

Topic of Lecture: Boundary layer Thickness

Introduction : (Maximum 5 sentences)

- It is defined as the distance from the solid boundary measured in y-direction to the point, where the velocity of fluid is approximately equal to 0.99 times the free stream velocity (U) of the fluid. It is denoted by d.

**Prerequisite knowledge for Complete understanding and learning of Topic:
(Max. Four important topics)**

- Boundary layer
- Thickness

Detailed content of the Lecture:

Boundary layer Thickness:

- When a viscous fluid flows along a fixed impermeable wall, or past the rigid surface of an immersed body, an essential condition is that the velocity at any point on the wall or other fixed surface is zero.
- The extent to which this condition modifies the general character of the flow depends upon the value of the viscosity.
- If the body is of streamlined shape and if the viscosity is small without being negligible, the modifying effect appears to be confined within narrow regions adjacent to the solid surfaces; these are called boundary layers.
- Within such layers the fluid velocity changes rapidly from zero to its main-stream value, and this may imply a steep gradient of shearing stress; as a consequence, not all the viscous terms in the equation of motion will be negligible, even though the viscosity, which they contain as a factor, is itself very small.

that the Reynolds number should be large, though not so large as to imply a breakdown of the laminar flow.

Types of boundary layer thickness:

Displacement thickness (d^*),

Momentum thickness (θ),

Energy thickness (d^{**}).

Displacement thickness:

The displacement thickness (d) is defined as the distance by which the boundary should be displaced to compensate for the reduction in flow rate on account of boundary layer formation.

$$d^* = \int [1 - (u/U)] dy$$

Momentum thickness:

The momentum thickness (θ) is defined as the distance by which the boundary should be displaced to compensate for the reduction in momentum of the flowing fluid on account of boundary layer formation.

$$\theta = \int [(u/U) - (u/U)^2] dy$$

Energy thickness:

The energy thickness (d^{**}) is defined as the distance by which the boundary should be displaced to compensate for the reduction in kinetic energy of the flowing fluid on account of boundary layer formation.

$$d^{**} = \int [(u/U) - (u/U)^3] dy$$

Video Content / Details of website for further learning (if any):

https://www.youtube.com/watch?v=b6hT_JbG9co

Important Books/Journals for further learning including the page nos.:

Bansal, R.K., "Fluid Mechanics and Hydraulics Machines", (5th edition), Laxmi publications (P) Ltd, New Delhi, 1995, Page No -613



MUTHAYAMMAL ENGINEERING COLLEGE

(An Autonomous Institution)

(Approved by AICTE, New Delhi, Accredited by NAAC & Affiliated to Anna University)
Rasipuram - 637 408, Namakkal Dist., Tamil Nadu



LECTURE HANDOUTS

L-13

Robotics and
Automation

II / III

Course Name with Code : 19RAC02 Fluid Mechanics and Machinery

Course Faculty : Dr.T.Yuvaraj

Unit : II

Topic of Lecture: Hydraulic and energy gradient

Introduction : (Maximum 5 sentences)

- This concept of hydraulic gradient line and total energy line is very useful in the study of flow of fluids through pipes. They are defined as
 - Hydraulic Gradient Line
 - Total Energy Line

**Prerequisite knowledge for Complete understanding and learning of Topic:
(Max. Four important topics)**

- Pressure head
- Fluid flow types
- Friction in a Pipe

Detailed content of the Lecture:

Hydraulic gradient and total energy line:

Hydraulic Gradient Line:

- It is defined as the line which gives the sum of pressure head (p/w) and datum head (z) of a flowing fluid in a pipe with respect to some reference line or it is the line which is obtained by joining the top of all vertical ordinates, showing the pressure head (p/w) of a flowing fluid in a pipe from the centre of the pipe. It is briefly written as H.G.L (Hydraulic Gradient Line).

Total Energy Line:

- It is defined as the line which gives the sum of pressure head, datum head and kinetic head of a flowing fluid in a pipe with respect to some reference line. It is also defined as the line which is obtained by joining the tops of all vertical ordinates showing the sum of pressure head and kinetic head from the centre of the pipe. It is briefly written as T E L

1. Water is flowing through a pipe of 5 cm diameter under a pressure of 29.43 N/cm² (gauge) and with mean velocity of 2.0 m/s. find the total head or total energy per unit weight of the water at cross – section, which is 5 cm above the datum line.

Solution

Diameter of the pipe 5 cm = 0.5 m.

Pressure $\rho = 29.43 \text{ N/cm}^2 = 29.23 \text{ N/m}^2$

Velocity, $v = 2.0 \text{ m/s}$.

Datum head $z = 5 \text{ m}$

Total head = Pressure head + Velocity head + Datum head

Pressure head = $(p / \rho g) = (29.43 \times 10^4 / (2 \times 9.81)) = 30 \text{ m}$

Kinetic head = $(v^2 / 2g) = (2 \times 2 / (2 \times 9.81)) = 0.204 \text{ m}$

Total head = $(p / (\rho g)) + (v^2 / 2g) + z$
 = $30 + 0.204 + 5 = 35.204 \text{ m}$

2. Water is flowing through two different pipes, to which an inverted differential manometer having an oil of sp. Gr 0.8 is connected the pressure head in the pipe A is 2 m of water, find the pressure in the pipe B for the manometer readings.

Solution

Pr heat at $A = \frac{P_A}{\rho g} = 2 \text{ m}$ of water.

$$P_A = p \times g \times 2 = 1000 \times 9.81 \times 2$$

$$= 19620 \text{ N/m}^2$$

$$\text{Pr below X – X in left limb} = P_A - \rho_1 g h_1$$

$$= 19620 - 1000 \times 9.81 \times 0.3$$

$$= 16677 \text{ N/m}^2$$

$$\text{Pr below X – X in right limb} = P_B - 1000 \times 9.81 \times 0.1 - 800 \times 9.81 \times 0.12 = P_B - 1922.76$$

Equating two pressure, we get,

$$P_B = 16677 + 1922.76 = 18599.76 \text{ N/m}^2 = 1.8599 \text{ N/cm}^2$$

Video Content / Details of website for further learning (if any):

<https://www.youtube.com/watch?v=0iLrTctDk7Y>

Important Books/Journals for further learning including the page nos.:

Bansal, R.K., "Fluid Mechanics and Hydraulics Machines", (5th edition), Laxmi publications (P) Ltd, New Delhi, 1995, Page No -491



MUTHAYAMMAL ENGINEERING COLLEGE

(An Autonomous Institution)

(Approved by AICTE, New Delhi, Accredited by NAAC & Affiliated to Anna University)
Rasipuram - 637 408, Namakkal Dist., Tamil Nadu



LECTURE HANDOUTS

L-14

Robotics and
Automation

II / III

Course Name with Code : 19RAC02 Fluid Mechanics and Machinery

Course Faculty : Dr.T.Yuvaraj

Unit : II

Topic of Lecture: Darcy – Weisbach equation.

Introduction : (Maximum 5 sentences)

- There are many types of losses of head for flowing liquids such as friction, inlet and outlet losses.
- The major loss is that due to frictional resistance of the pipe, which depends on the inside roughness of the pipe.
- The common formula for calculating the loss of head due to friction is Darcy's one.

Prerequisite knowledge for Complete understanding and learning of Topic: (Max. Four important topics)

- Friction
- Loss of Head
- Coefficient of Friction

Detailed content of the Lecture:

Darcy's formula for friction loss of head:

For a flowing liquid, water in general, through a pipe, the horizontal forces on water between two sections (1) and (2) are:

$$P_1 A = P_2 A + F_R$$

P₁ = Pressure intensity at (1).

A = Cross sectional area of pipe.

P₂ = Pressure intensity at (2).

F_R = Frictional Resistance at (2).

$$F_R / \gamma A = (P_1 / \gamma) - (P_2 / \gamma) = h_f$$

Where h_f = Loss of pressure head due to friction

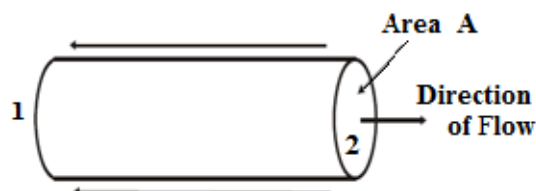

It is found experimentally that:

$$F_R = \text{Factor} \times \text{Wetted Area} \times \text{Velocity}^2$$

$$F_R = (\gamma f / 2g) \times (\pi d L) \times v^2$$

Where, f = Friction coefficient.

d = Diameter of pipe.

L = Length of pipe.

$$hf = (\gamma f / 2g) \times (\pi d L) \times v^2 / \gamma (\pi d^2 / 4)$$

$$h_f = \frac{4f}{2g} \times \frac{LV^2}{d} = \frac{4f.L.V^2}{d \times 2g}$$

$$h_f = \frac{f.L.V^2}{d \times 2g}$$

It may be substituted for $[v = Q / (\pi d^2 / 4)]$ in the last equation to get the head loss for a known discharge. Thus,

$$h_f = \frac{32f.L.Q^2}{H^2 d \times g^5}$$

- **Expression for loss of head due to Friction in pipes (Darcy weisbach's Equation):**

$$h_f = \frac{4f}{2g} \times \frac{LV^2}{d} = \frac{4f.L.V^2}{d \times 2g}$$

- The above equation is known as Darcy- weisbach's equation. This is commonly used for finding loss of head due to friction in pipes.

$$h_f = \frac{f.L.V^2}{d \times 2g}$$

- Where

hf = Loss of head due to friction.

f = Coefficient of friction in pipe.

D = Diameter of pipe.

L = Length of the pipe

V = Mean velocity of flow.

Chevy's formula

$$V = C \sqrt{mi}$$

- **Coefficient of friction in viscous flow:**

Coefficient of friction between pipe and fluid in viscous flow **$f = 16/ Re$**

Where, $f = 16/ Re$ = Reynolds number

1. A pipe 1 m diameter and 15 km long transmits water of velocity of 1 m/sec. The friction coefficient of pipe is 0.005. Calculate the head loss due to friction?

Solution

$$h_f = \frac{f.L.V^2}{d \times 2g}$$
$$= 4 \times 0.005 \times 15000 \times 1^2 / 2 \times 9.81 \times 1$$
$$= 15.29 \text{ m}$$

Video Content / Details of website for further learning (if any):

https://www.youtube.com/watch?v=_mnpr3AsatY

Important Books/Journals for further learning including the page nos.:

Bansal, R.K., "Fluid Mechanics and Hydraulics Machines", (5th edition), Laxmi publications (P) Ltd, New Delhi, 1995, Page No -436



MUTHAYAMMAL ENGINEERING COLLEGE

(An Autonomous Institution)

(Approved by AICTE, New Delhi, Accredited by NAAC & Affiliated to Anna University)
Rasipuram - 637 408, Namakkal Dist., Tamil Nadu



LECTURE HANDOUTS

L-15,16

Robotics and
Automation

II / III

Course Name with Code : 19RAC02 Fluid Mechanics and Machinery

Course Faculty : Dr.T.Yuvaraj

Unit : II

Topic of Lecture: Friction factor, Moody Diagram

Introduction : (Maximum 5 sentences)

- Friction factor (μ) is defined as the ratio between the force required to move a section of pipe and the vertical contact force applied by the pipe on the seabed

**Prerequisite knowledge for Complete understanding and learning of Topic:
(Max. Four important topics)**

- Relative roughness
- Types of Forces

Detailed content of the Lecture:

- Friction factor, in general, was found to be a function of the Reynolds number and pipe relative roughness. Relative roughness is defined here as the ratio of the absolute roughness ϵ of the pipe inside wall to the pipe inside diameter:

$$(2.34)k=\epsilon d$$

where:

k = pipe relative roughness, –,

ϵ = pipe absolute roughness, in,

d = pipe diameter, in.

- Typical absolute roughness values are $\epsilon = 0.0006$ in for new and $\epsilon = 0.009$ in for used well tubing.
- There are several formulae describing friction factors for different flow conditions. Most of them are included in the Moody diagram [18], which is a graphical presentation of Darcy–Weisbach-type f values.
- Use of this chart, given in Fig. is generally accepted in the petroleum industry.

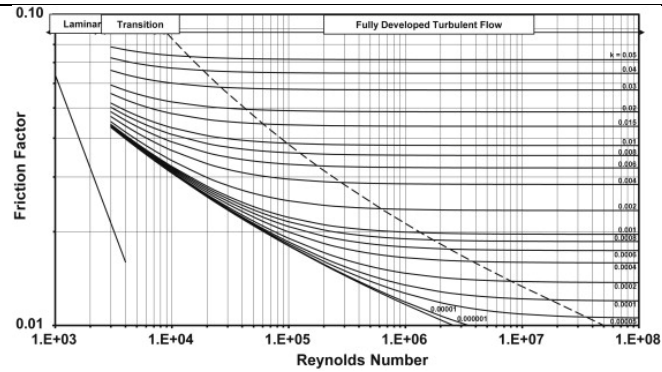

Moody Diagram

- 1) For laminar flow, $f = 16 / Re$
- 2) For transitional flow, pipes' flow lies outside this region.
- 3) For smooth turbulent (a limiting line of turbulent flow), all values of relative roughness (ks/d) tend toward this line as R decreases. Blasius equation: $f = 0.079 / Re^{0.25}$
- 4) For transitional turbulent, it is the region where (f) varies with both (ks/d) & (Re). Most pipes lie in this region.
- 5) For rough turbulent, (f) is constant for given (ks/d) and is independent of (Re).

Moody Diagram

- The Moody diagram represents the complete friction factor map for laminar and all turbulent regions of pipe flows.
- It is commonly used in estimating friction factor in pipe flow. If the Moody diagram is not available, we must use a trial and error solution to calculate the friction factor.
- To use the Moody diagram for determining the friction factor f we first calculate the relative roughness (e/D) and the Reynolds number R for the flow.
- Next, for this value of R on the horizontal axis, draw a vertical line that intersects with the appropriate relative roughness (e/D) curve. From this point of intersection on the (e/D) curve, we go horizontally to the left and read the value of the friction factor f on the vertical axis on the left.

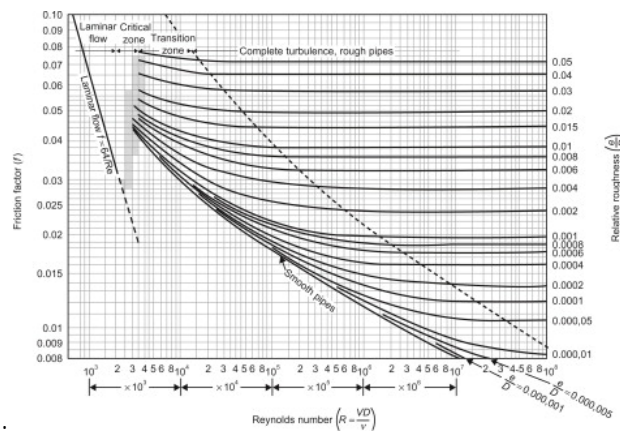

1. Water flows in a steel pipe ($d = 40 \text{ mm}$, $k = 0.045 \times 10^{-3} \text{ m}$, $\mu = 0.001 \text{ k/ms}$) with a rate of 1 lit/s. Determine the friction coefficient and the head loss due to friction per meter length of the pipe using: 1- Moody chart? 2- Smooth pipe formula?

Solution

$$\begin{aligned}v &= Q / A \\&= (0.001) / ((\pi / 4) \times (0.04)^2) \\&= 0.796 \text{ m/s} \\Re &= \rho v d / \mu \\&= (1000 \times 0.796 \times 0.04) / 0.001 \\&= 31840 > 4000\end{aligned}$$

Therefore flow is Turbulent flow.

1. **Moody chart:**

$$\begin{aligned}k/d &= 0.045 \times 10^{-3} / 0.04 \\&= 0.0011 \text{ \& } Re = 31840 \\&\text{from the chart, } f = 0.0065 \\hf &= 4 f L v^2 / 2 g d \\&= 4 \times 0.0065 \times 1 \times (0.796)^2 / 2 \times 9.81 \times 0.04 \\&= 0.0209 \text{ m / m of pipe}\end{aligned}$$

2. **Smooth pipe (Blasius equation):**

$$\begin{aligned}f &= 0.079 / Re^{0.25} \\&= 0.079 / (31840) \\&= 0.0059 \\hf &= 4 f L v^2 / 2 g d \\&= 4 \times 0.0059 \times 1 \times (0.796)^2 / 2 \times 9.81 \times 0.04 \\&= 0.02 \text{ m / m of pipe}\end{aligned}$$

Video Content / Details of website for further learning (if any):

<https://www.youtube.com/watch?v=eZDQzYhIgrM>

Important Books/Journals for further learning including the page nos.:

Bansal, R.K., "Fluid Mechanics and Hydraulics Machines", (5th edition), Laxmi publications (P) Ltd, New Delhi, 1995, Page No -436



MUTHAYAMMAL ENGINEERING COLLEGE

(An Autonomous Institution)

(Approved by AICTE, New Delhi, Accredited by NAAC & Affiliated to Anna University)
Rasipuram - 637 408, Namakkal Dist., Tamil Nadu



LECTURE HANDOUTS

L-17

Robotics and
Automation

II / III

Course Name with Code : 19RAC02 Fluid Mechanics and Machinery

Course Faculty : Dr.T.Yuvaraj

Unit : II

Topic of Lecture: Commercial Pipes – Minor Losses

Introduction : (Maximum 5 sentences)

- Losses due to the local disturbances of the flow in the conduits such as changes in cross section, projecting gaskets, elbows, valves and similar items are called minor losses.

**Prerequisite knowledge for Complete understanding and learning of Topic:
(Max. Four important topics)**

- Expansion
- Contraction
- Bend
- Obstruction

Detailed content of the Lecture:

- Minor losses in a pipe:

The loss of energy or head due to change of velocity of the flowing fluid in magnitude or direction is called minor losses.

- Sudden expansion in pipe.
- Sudden contraction in pipe.
- Bend in pipe.
- Due to obstruction in pipe .
- pipe fittings and obstruction in the pipe

- **Loss of head due to sudden enlargement of the pipe:**

$$h_e = (V_1 - V_2)^2 / 2g$$

Where, h_e = Loss of head due to sudden enlargement of pipe .

V_1 = Velocity of flow at section 1-1

V_2 = Velocity of flow at section 2-2

- **Loss of head due to sudden contraction:**

$$h_c = 0.5 V^2 / 2g$$

Where, h_c = Loss of head due to sudden contraction .

V = Velocity at outlet of pipe.

- **Loss of head at the entrance of the pipe:**

$$h_i = 0.5 V^2 / 2g$$

Where, h_i = Loss of head at entrance of pipe .

V = Velocity of liquid at inlet and outlet of the pipe.

- **Drop of pressure for a given length of a pipe:**

$$P_1 - P_2 / \rho g = 32 \mu \bar{U} L / \rho g D^2$$

Where, $P_1 - P_2$ is drop of pressure.

- **Loss of head at exit of the pipe:**

$$h_o = V^2 / 2g$$

h_o = Loss of head at exit of the pipe.

V = Velocity of liquid at inlet and outlet of the pipe

- **Loss of head due to an obstruction in pipe:**

$$\text{Loss of head due to an obstruction} = V^2 / 2g (A / C_c (A - a) - 1)^2$$

Where, A = area of pipe

a = Max area of obstruction

V = Velocity of liquid in pipe

$A - a$ = Area of flow of liquid at section 1-1

- **Secondary Losses of Head in Pipes**

$$h_s = K (v^2 / 2g)$$

Obstruction	K
Tank Exit	0.5
Tank Entry	1.0
Smooth Bend	0.3
Standard T	1.8
Strainer	2.0
Angle Valve, wide open	5.0
Gate Valve:	0.2
3/4 open	1.2
1/2 open	5.6
1/4 open	24.0
Sudden Enlargement	0.1

1. A pipe transmits water from a tank A to point C that is lower than water level in the tank by 4 m. The pipe is 100 mm diameter and 15 m long. The highest point on the pipe B is 1.5 m above water level in the tank and 5 m long from the tank. The friction factor ($4f$) is 0.08, with sharp inlet and outlet to the pipe. Determine the velocity of water leaving the pipe at C?

Solution

Applying Bernoulli's equation between A and C,

Head loss due to entry (tank exit, from table) = $0.5 (v_C^2/2g)$

Head loss due to exit into air without contraction = 0

$$Z_A + 0 + 0 = Z_C + 0 + (v_C^2/2g) + 0.5 (v_C^2/2g) + 0 + (4fLV_C^2 / 2.g.d)$$

$$4 = (v_C^2/2g) \times \{1 + 0.5 + (4 \times 0.08 \times 15) / 0.1\}$$

$$v_C = 1.26 \text{ m/s}$$

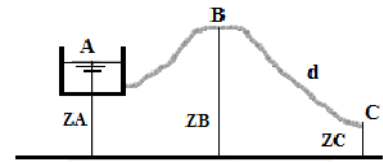

Video Content / Details of website for further learning (if any):

<https://www.youtube.com/watch?v=jQ1CUKiWRpk>

Important Books/Journals for further learning including the page nos.:

Bansal, R.K., "Fluid Mechanics and Hydraulics Machines", (5th edition), Laxmi publications (P) Ltd, New Delhi, 1995, Page No -471



MUTHAYAMMAL ENGINEERING COLLEGE

(An Autonomous Institution)

(Approved by AICTE, New Delhi, Accredited by NAAC & Affiliated to Anna University)
Rasipuram - 637 408, Namakkal Dist., Tamil Nadu



LECTURE HANDOUTS

L-18

Robotics and
Automation

II / III

Course Name with Code : 19RAC02 Fluid Mechanics and Machinery

Course Faculty : Dr.T.Yuvaraj

Unit : II

Topic of Lecture: Flow through pipes in series and in parallel

Introduction : (Maximum 5 sentences)

- Pipes in series are pipes with different diameters and lengths connected together forming a pipe line.
- Pipes in parallel are pipes with different diameters and same lengths, where each pipe is connected separately to increase the discharge

Prerequisite knowledge for Complete understanding and learning of Topic: (Max. Four important topics)

- Parallel Connections
- Series Connections

Detailed content of the Lecture:

- Consider pipes in series discharging water from a tank with higher water level to another with lower water level, as shown in the figure.
- Neglecting secondary losses, it is obvious that the total head loss H_L between the two tanks is the sum of the friction losses through the pipe line.
- Consider pipes in parallel discharging water from a tank with higher water level to another with lower water level, as shown in the figure.

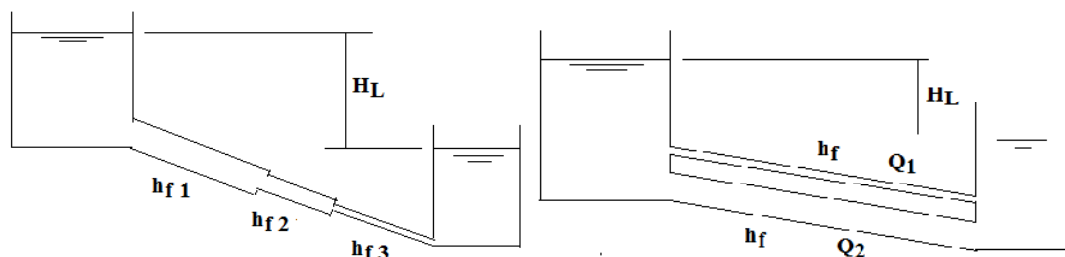

Neglecting secondary losses

- **Flow through pipes in series or Flow through compound pipes:**

$$H = \frac{4fL_1 V_1^2}{d_1 \times 2g} + \frac{4fL_2 V_2^2}{d_2 \times 2g} + \frac{4fL_3 V_3^2}{d_3 \times 2g}$$

$$= \frac{4f}{2g} \left[\frac{L_1 V_1^2}{d_1} + \frac{L_2 V_2^2}{d_2} + \frac{L_3 V_3^2}{d_3} \right]$$

- **Flow through parallel pipes:**

Loss of head for branch pipe 1 = Loss of head for branch pipe 2

$$\text{or} \quad \frac{4f_1 L_1 V_1^2}{d_1 \times 2g} = \frac{4f_2 L_2 V_2^2}{d_2 \times 2g}$$

$$\text{If } f_1 = f_2, \text{ then} \quad \frac{L_1 V_1^2}{d_1 \times 2g} = \frac{L_2 V_2^2}{d_2 \times 2g}$$

Example

A pipe, 40 m long, is connected to a water tank at one end and flows freely in atmosphere at the other end. The diameter of pipe is 15 cm for first 25 m from the tank, and then the diameter is suddenly enlarged to 30 cm. Height of water in the tank is 8 m above the centre of pipe. Darcy's coefficient is 0.01.

Determine the discharge neglecting minor losses?

Solution

Loss due to friction, $h_{Lf} = h_{f1} + h_{f2}$

$$h_f = \frac{32 f L Q^2}{\pi^2 g d^5} \quad f = 0.01$$

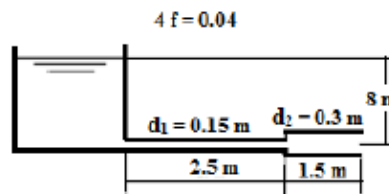

$$\text{Total losses,} \quad h_T = Q^2 \left(\frac{32 f L_1}{\pi^2 g d_1^5} + \frac{32 f L_2}{\pi^2 g d_2^5} \right)$$

$$8 = Q^2 \left(\frac{(32 \times 0.01) \times (25)}{\pi^2 g (0.15)^5} + \frac{(32 \times 0.01) (15)}{\pi^2 g (0.3)^5} \right)$$

$$\therefore Q = 0.087 \text{ m}^3/\text{sec}$$

Video Content / Details of website for further learning (if any):

https://www.youtube.com/watch?v=O-V6_yQ81iM

Important Books/Journals for further learning including the page nos.:

Bansal, R.K., "Fluid Mechanics and Hydraulics Machines", (5th edition), Laxmi publications (P) Ltd, New Delhi, 1995, Page No -502



MUTHAYAMMAL ENGINEERING COLLEGE

(An Autonomous Institution)

(Approved by AICTE, New Delhi, Accredited by NAAC & Affiliated to Anna University)
Rasipuram - 637 408, Namakkal Dist., Tamil Nadu



LECTURE HANDOUTS

L-19

Robotics and
Automation

II / III

Course Name with Code : 19RAC02 Fluid Mechanics and Machinery

Course Faculty : Dr.T.Yuvaraj

Unit : III

Topic of Lecture: Need for dimensional analysis

Introduction : (Maximum 5 sentences)

- Dimensional Analysis is a very basic aspect of measurement and has many applications in real life physics.
- We use dimensional analysis for three prominent reasons, they are: Consistency of a dimensional equation. Derive relation between physical quantities in physical phenomena.

**Prerequisite knowledge for Complete understanding and learning of Topic:
(Max. Four important topics)**

- Units
- Dimensions

Detailed content of the Lecture:

Dimensional analysis.

Dimensional analysis is defined as a mathematical technique used in research work for design and conducting model tests.

Fundamental dimensions

The fundamental units quantities such as length (L), mass (M), and time (T) are fixed dimensions known as fundamental dimensions.

Units.

Unit is defined as a yardstick to measure physical quantities like distance, area, volume, mass etc.

Dimensions for velocity.

Velocity is the distance (L) travelled per unit time (T) Velocity = Distance/ Time = $[L/T]$ =

LT-1

Dimensional Homogeneity:

Dimensional homogeneity means the dimensions of each terms in an equation on both sides equal. Thus if the dimensions of each term on both sides of an equation are the same the equation is known as dimensionally homogeneous equation. The powers of fundamental dimensions (i.e., L, M, T) on both sides of the equation will be identical for a dimensionally homogeneous equation.

Let us consider the equation $v = \sqrt{2gh}$

$$\text{Dimension of L.H.S} = V = \frac{L}{T} = LT^{-1}$$

$$\begin{aligned}\text{Dimension of R.H.S} &= \sqrt{2gH} = \sqrt{\frac{L}{T^2} \times L} = \sqrt{\frac{L^2}{T^2}} \\ &= \frac{L}{T} = LT^{-1}\end{aligned}$$

$$\text{Dimension of L.H.S} = \text{Dimension of R.H.S} = LT^{-1}$$

Equation $v = \sqrt{2gh}$ is dimensionally homogeneous

Dimensional Analysis and Applications.

The dimensional equations have got following three uses:

- To check the correctness of a physical equation.
- To derive the relation between different physical quantities involved in a physical phenomenon.
- To convert the physical quantity from one system to another.
- To check the correctness of a physical relation.
- To obtain relationship among various physical quantities involved.
- To find dimensions of constant in a physical relation

Video Content / Details of website for further learning (if any):

<https://www.youtube.com/watch?v=uRpLHUtPa60>

Important Books/Journals for further learning including the page nos.:

Bansal, R.K., "Fluid Mechanics and Hydraulics Machines", (5th edition), Laxmi publications (P) Ltd, New Delhi, 1995, Page No -559



MUTHAYAMMAL ENGINEERING COLLEGE

(An Autonomous Institution)

(Approved by AICTE, New Delhi, Accredited by NAAC & Affiliated to Anna University)
Rasipuram - 637 408, Namakkal Dist., Tamil Nadu



LECTURE HANDOUTS

L-20, 21

Robotics and
Automation

II / III

Course Name with Code : 19RAC02 Fluid Mechanics and Machinery

Course Faculty : Dr.T.Yuvaraj

Unit : III

Topic of Lecture: Methods of Dimensional Analysis

Introduction : (Maximum 5 sentences)

- If the number of variables involved in a physical phenomenon is known, then the relation among the variables can be determined by the following two methods.
 - 1.Rayleigh's method, and
 2. Buckingham's π theorem

**Prerequisite knowledge for Complete understanding and learning of Topic:
(Max. Four important topics)**

- Independent Variable
- Dependent Variable
- Dimensionless Numbers

Detailed content of the Lecture:

METHODS OF DIMENSIONAL ANALYSIS:

1.Rayleigh's method:

This method is used for determining the expression for a variable which depends upon maximum three or four variables only. If the number of independent variables becomes more than four then it is very difficult to find the expression for the dependent variable.

Let X is a variable, which depends on X_1 , X_2 and X_3 variables. Then according to Rayleigh's method, X is function of X_1 , X_2 and X_3 and mathematically it is written as

$$X = f [X_1, X_2, X_3]$$

This can also be written as $X = K X_1^a. X_2^b. X_3^c$

Where K is constant and a, b and c are arbitrary powers.

The values of a, b and c are obtained by comparing the powers of the fundamental dimension on both sides. Thus the expression is obtained for dependent variable

2. Buckingham's π theorem:

If there are n variables (independent and dependent variables) in a physical phenomenon and if these variables contain m fundamental dimensions (M, L, T), then the variables are arranged into $(n-m)$ dimensionless numbers. Each term is called π term.

Let $X_1, X_2, X_3, \dots, X_n$ are the variables involved in a physical problem. Let X_1 be the dependent variable and X_2, X_3, \dots, X_n are the independent variables on which X_1 depends. Then X_1 is a function of X_2, X_3, \dots, X_n and mathematically it is expressed as

$$X_1 = f(X_2, X_3, \dots, X_n) \text{ -----(1)}$$

The above equation can also be written as

$$f_1(X_1, X_2, X_3, \dots, X_n) = 0 \text{ -----(2)}$$

The above (2) is a dimensionally homogeneous equation. It contains n variables. If there are m fundamental dimensions then according to Buckingham's π theorem, equation (2) can be written on terms of dimensionless groups or π - terms is equal to $(n-m)$. Hence equation (2) becomes as

$$f_1(\pi_1, \pi_2, \pi_3, \dots, \pi_{n-m}) = 0. \text{ -----(3)}$$

Each π - term is dimensionless and is independent of the system. Division or multiplication by a constant does not change the character of the π - term. Each π - term contains $m+1$ variables, where m is the number of fundamental dimensions and is also called repeating variables. Let in the above case X_2, X_3 , and X_n are repeating variables if the fundamental dimension m (M, L, T) = 3. Then each π - term is written as

$$\pi_1 = X_2^{a_1} \cdot X_3^{b_1} \cdot X_4^{c_1} \cdot X_1$$

$$\pi_2 = X_2^{a_2} \cdot X_3^{b_2} \cdot X_4^{c_2} \cdot X_5$$

$$\pi_{n-m} = X_2^{a_{n-m}} \cdot X_3^{b_{n-m}} \cdot X_4^{c_{n-m}} \cdot X_n \text{ -----(4)}$$

Each equation is solved by the principle of dimensional homogeneity and values of a_1, b_1, c_1 etc. are obtained. These values are substituted in equation (4) and values of $\pi_1, \pi_2, \pi_3, \dots, \pi_{n-m}$ are obtained. These values of π 's are substituted in equation (3). The final equation for the phenomenon is obtained by expressing any one of the π - terms as a function of others as

$$\pi_1 = \Phi[\pi_2, \pi_3, \dots, \pi_{n-m}]$$

$$\pi_2 = \Phi[\pi_1, \pi_3, \dots, \pi_{n-m}] \text{ -----(5)}$$

Method of selecting Repeating variables:

The number of repeating variables are equal to the number of fundamental dimensions of the problem. The choice of repeating variables is governed by the following considerations.

1. As far as possible, the dependent variable should not be selected as repeating variable.
2. The repeating variables should be chosen in such a way that one variable contains geometric property, other variable contains flow property and third variable contains fluid property.

Variables with geometric property are (i) Length, l (ii) d (iii) Height H etc.

Variables with flow property are (i) Velocity, V (ii) Acceleration etc.

Variables with fluid property are (i) μ (ii) ρ (iii) w etc.

3. The repeating variables selected should not form a dimensionless group.
4. The repeating variables together must have the same number of fundamental dimensions.
5. No two repeating variables should have the same dimensions.

In most of fluid mechanics problems, the choice of repeating variables may be (i) d, v, ρ (ii) l, v, ρ or (iii) l, v, μ or (iv) d, v, μ .

For predicting the performance of the hydraulic structures (such as dams, spill ways etc.) or hydraulic machines (such as turbines, pumps etc.), before actually constructing or manufacturing, models of the structures or machines are made and tests are performed on them to obtain the desired information.

The resisting force of (R) of a supersonic flight can be considered as dependent upon the length of aircraft ‘ l ’, velocity ‘ V ’, air viscosity ‘ μ ’, air density ‘ ρ ’, and bulk modulus of air ‘ k ’. Express the functional relationship between these variables and the resisting force

Solution:

$$\text{Step 1. } R = f(l, V, \mu, \rho, k)$$

$$\Phi(R, l, V, \mu, \rho, k) = 0$$

$$\text{Number of variables, } n = 6$$

$$\text{Number of primary variable, } m = 3$$

$$\text{Number of } \pi \text{ terms} = n - m = 6 - 3 = 3$$

$$f(\pi_1, \pi_2, \pi_3) = 0$$

Step 2. Assume l, V and ρ to be the repeating variables. $\pi_1 = l^x, V^y, \rho^z, R$

$$M^0 L^0 T^0 = [L]^x [LT^{-1}]^y [ML^{-3}]^z [MLT^{-2}]$$

$$z_1 + 1 = 0; \quad x_1 + y_1 - 3z_1 + 1 = 0 \quad -y_1 - 2 = 0, \quad z_1 = -1$$

$$x_1 - 2 + 3 + 1 = 0 \quad y_1 = -2.$$

$$x_2 = -2.$$

$$\pi_1 = l^{-2} V^{-2} \rho^{-1}$$

$$R = \frac{R}{l^2 V^2 \rho}$$

$$\text{Step 3: } \pi_2 = l^x V^y \rho^z \mu$$

$$M^0 L^0 T^0 = [L]^x [LT^{-1}]^y [ML^{-3}]^z [ML^{-1}T^{-1}]$$

$$z_1 + 1 = 0; \quad x_2 + y_2 - 3z_2 - 1 = 0 \quad -$$

$$y_2 - 1 = 0 \quad z_1 = -1 \quad x_2 - 1 + 3 - 1 = 0 \quad y_2 = -1.$$

$$x_2 = -1.$$

$$\pi_2 = l^{-1} V^{-1} \rho^{-1}$$

$$\mu = \frac{\mu}{l V \rho}$$

Step 4. $\pi_2 = l^x V^y \rho z K$

$$M^0 L^0 T^0 = [L]^x [LT^{-1}]^y [ML^{-3}]^z [ML^{-1}T^{-2}]$$

$$Z_3 + 1 = 0; \quad x_3 + y_3 - 3z_3 - 1 = 0 \quad -y_3 - 2 = 0$$

$$Z_3 = -1 \quad x_3 - 2 + 3 - 1 = 0 \quad y_2 = -2.$$

$$x_3 = 0.$$

$$\pi_2 = l^0 V^{-2} \rho^{-1} K = \frac{K}{\rho V^2}$$

Step 5.

$$\Phi(\pi_1, \pi_2, \pi_3) = 0 \quad \Phi\left(\frac{R}{l^2 V^2 \rho}, \frac{\mu}{lV\rho}, \frac{K}{\rho V^2}\right) = 0$$

$$R = l^2 V^2 \rho \Phi\left(\frac{\mu}{lV\rho}, \frac{K}{\rho V^2}\right) = 0$$

Video Content / Details of website for further learning (if any):

<https://www.youtube.com/watch?v=6iqme-HilyM>

Important Books/Journals for further learning including the page nos.:

Bansal, R.K., "Fluid Mechanics and Hydraulics Machines", (5th edition), Laxmi publications (P) Ltd, New Delhi, 1995, Page No -565



MUTHAYAMMAL ENGINEERING COLLEGE

(An Autonomous Institution)

(Approved by AICTE, New Delhi, Accredited by NAAC & Affiliated to Anna University)
Rasipuram - 637 408, Namakkal Dist., Tamil Nadu



LECTURE HANDOUTS

L-22

Robotics and
Automation

II / III

Course Name with Code : 19RAC02 Fluid Mechanics and Machinery

Course Faculty : Dr.T.Yuvaraj

Unit : III

Topic of Lecture: Similitude

Introduction : (Maximum 5 sentences)

- Similitude is a concept applicable to the testing of engineering models. A model is said to have similitude with the real application if the two share geometric similarity, kinematic similarity and dynamic similarity. Similarity and similitude are interchangeable in this context.
- The term dynamic similitude is often used as a catch-all because it implies that geometric and kinematic similitude have already been met.
- Similitude's main application is in hydraulic and aerospace engineering to test fluid flow conditions with scaled models. It is also the primary theory behind many textbook formulas in fluid mechanics.
- The concept of similitude is strongly tied to dimensional analysis.

Prerequisite knowledge for Complete understanding and learning of Topic: (Max. Four important topics)

- Similarity
- Kinematic properties
- Dynamic Properties

Detailed content of the Lecture:

SMILITUDE –TYPES OF SIMILARITIES:

Similitude is defined as the similarity between the model and its prototype in every respect, which means that the model and prototype are completely similar. Three types of similarities must exist between the model and prototype. They are

1. Geometric Similarity
2. Kinematic Similarity
3. Dynamic Similarity

Geometric Similarity:

The geometric similarity is said to exist between the model and the prototype if the ratio of all corresponding linear dimension in the model and prototype are equal.

L_m = Length of model , b_m = Breadth of model

D_m = Diameter of model A_m = area of model

V_m = Volume of model

and L_p, B_p, D_p, A_p, V_p = Corresponding values of the prototype.

For geometric similarity between model and prototype, we must have the relation,

$$\frac{L_p}{L_m} = \frac{b_p}{b_m} = \frac{D_p}{D_m} = L_r$$

L_r is called the scale ratio.

For area's ratio and volume's ratio the relation should be as given below.

$$\frac{A_p}{A_m} = \frac{L_p \times b_p}{L_m \times b_m} = L_r \times L_r = L_r^2$$

$$\frac{V_p}{V_m} = \left(\frac{L_p}{L_m}\right)^3 = \left(\frac{b_p}{b_m}\right)^3 = \left(\frac{D_p}{D_m}\right)^3$$

Kinematic Similarity :

Kinematic similarity means the similarity of motion between model and prototype. Thus kinematic similarity is said to exist between the model and the prototype if the ratios of the velocity and acceleration at the corresponding points in the model and at the corresponding points in the prototype are the same. Since the velocity and acceleration are vector quantities, hence not only the ratio of magnitude of velocity and acceleration at the corresponding points in the model and prototype should be same, but the directions of velocity and accelerations at the corresponding points in the model and prototype also should be parallel.

V_{p1} = velocity of fluid at point 1 in prototype,

V_{p2} = velocity of fluid at point 2 in prototype,

a_{p1} = Acceleration of fluid at point 1 in prototype,

a_{p2} = Acceleration of fluid at point 2 in prototype,

$V_{m1}, V_{m2}, a_{m1}, a_{m2}$ = Corresponding values at the corresponding points of fluid velocity and acceleration in the model.

For kinematic similarity, we have

$$\frac{V_{p1}}{V_{m1}} = \frac{V_{p2}}{V_{m2}} = V_r$$

where V_r is the velocity ratio.

For acceleration, we have $\frac{a_{p1}}{a_{m1}} = \frac{a_{p2}}{a_{m2}} = a_r$

where a_r is the acceleration ratio.

Also the directions of the velocities in the model and prototype should be same.

Dynamic Similarity:

Dynamic similarity means the similarity of forces between the model and prototype. Thus dynamic similarity is said to exist between the model and prototype if the ratios of the corresponding forces acting at the corresponding points are equal. Also the directions of the corresponding forces at the corresponding points should be same.

$(F_i)_p$ = Inertia force at a point in prototype,

$(F_v)_p$ = Viscous force at the point in prototype,

$(F_g)_p$ = Gravity force at the point in prototype,

$(F_i)_m, (F_v)_m, (F_g)_m$ = Corresponding values of forces at the corresponding point in model.

Then for dynamic similarity, we have

$$\frac{(F_i)_p}{(F_i)_m} = \frac{(F_v)_p}{(F_v)_m} = \frac{(F_g)_p}{(F_g)_m} = F_r$$

where F_r is the force ratio.

Also the directions of the corresponding forces at the corresponding points in the model and prototype should be same.

Video Content / Details of website for further learning (if any):

<https://www.youtube.com/watch?v=leosmNkmugs>

Important Books/Journals for further learning including the page nos.:

Bansal, R.K., "Fluid Mechanics and Hydraulics Machines", (5th edition), Laxmi publications (P) Ltd, New Delhi, 1995, Page No -579



MUTHAYAMMAL ENGINEERING COLLEGE

(An Autonomous Institution)

(Approved by AICTE, New Delhi, Accredited by NAAC & Affiliated to Anna University)
Rasipuram - 637 408, Namakkal Dist., Tamil Nadu



LECTURE HANDOUTS

L-23,24

Robotics and
Automation

II / III

Course Name with Code : 19RAC02 Fluid Mechanics and Machinery

Course Faculty : Dr.T.Yuvaraj

Unit : III

Topic of Lecture: Discussion on dimensionless parameters

Introduction : (Maximum 5 sentences)

- Dimensionless parameters are calculated as the ratio of the dimensional coordinate to a characteristic value. The reaction-diffusion PDE for glucose become dimensionless when substituted
- Dimensionless numbers or non-dimensional numbers are those which are useful to determine the flow characteristics of a fluid. Inertia force always exists if there is any mass in motion. Dividing this inertia force with other forces like viscous force, gravity force, surface tension, elastic force, or pressure force, gives us the dimensionless numbers.

**Prerequisite knowledge for Complete understanding and learning of Topic:
(Max. Four important topics)**

- Inertia Force
- Viscous Force
- Pressure Force

Detailed content of the Lecture:

DIMENSIONLESS NUMBERS:

Dimensionless numbers are those numbers which are obtained by dividing the inertia force by viscous force or pressure force or surface tension force or elastic force. As this is a ratio of one force to the other force, it will be a dimensionless number. These dimensionless numbers are also called non-dimensional parameters. The following are the important dimensionless numbers:

1. Reynold's number
2. Froud's number
3. Euler's number
4. Weber's number

1. Reynold's number: It is defined as the ratio of inertia force of a flowing fluid and the viscous force of the fluid. The expression for Reynold's number is obtained as

$$R_e = \frac{V \times d}{\nu} \quad \text{or} \quad \frac{\rho V d}{\mu}$$

2. Froud's Number (F_e): The Froud's Number is defined as the square root of the ratio of inertia force of a flowing fluid to the gravitational force. Mathematically, it is expressed as

$$F_e = \sqrt{\frac{F_i}{F_g}}$$

$$= \sqrt{\frac{\rho A V^2}{\rho A L g}} = \sqrt{\frac{V^2}{L g}} = \frac{V}{\sqrt{L g}}$$

3. Euler's number (E_u): It is defined as the square root of the ratio of inertia force of a flowing fluid to the surface tension force. Mathematically, it is expressed as

$$\text{Euler's number} \quad E_u = \sqrt{\frac{F_i}{F_p}}$$

4. Weber's number (W_e): It is defined as the square root of the ratio of inertia force of a flowing fluid to the surface tension force. Mathematically, it is expressed as

$$\text{Weber's number} \quad W_e = \sqrt{\frac{F_i}{F_g}}$$

5. Mach number (M): Mach number is defined as the square root of the ratio of inertia force of a flowing fluid to the elastic force. Mathematically, it is expressed as

$$\text{Mach number} \quad M = \sqrt{\frac{\text{Inertia force}}{\text{Elastic force}}} = \sqrt{\frac{F_i}{F_e}}$$

$$M = \frac{V}{C}$$

1. **A 7.2 m height and 15m long spill way discharges 94 m³/s discharge under a head of 2.0m. If a 1:9 scale model of this spillway is to be constructed, determine model dimensions, head over spillway model and the model discharge. If model experience a force of 7500N (764.53Kgf), determine force on the prototype.**

Given:

For prototype: height $h_p = 7.2\text{m}$

Length, $L_p = 15\text{m}$

Discharge $Q_p = 94 \text{ m}^3/\text{s}$

Head, $H_p = 2.0\text{m}$

Size of model = $1/9$ of the size of prototype

Linear scale ratio, $L_r = 9$

Force experienced by model $F_p = 7500\text{N}$

Find : (i) Model dimensions i.e., height and length of model (h_m and L_m)

(ii). Head over model i.e., H_m

(iii). Discharge through model i.e., Q_m

(iv). Force on prototype (i.e., F_p)

(i). Model dimensions (h_m and L_m)

$$h_p / h_m = L_p / L_m = L_r = 9$$

$$h_m = h_p / 9 = 7.2 / 9 = 0.8 \text{ m}$$

$$L_m = L_p / 9 = 15 / 9 = 1.67$$

(ii). Head over model (H_m)

$$h_p / H_m = L_r$$

$$H_m = H_p / 9 = 2 / 9 = 0.222 \text{ m.}$$

(iii) Discharge through model (Q_m)

Using equation we get, $Q_p / Q_m = L_r^{2.5}$

$$Q_m = (Q_p / L_r^{2.5})$$

$$= 0.387 \text{ m}^3/\text{s}$$

(iv). Force on the prototype (F_p)

Using $F_r = F_p / F_m = L^3$

$$= F_p = F_m \times L^3$$

$$= 7500 \times 9^3$$

$$= 5467500\text{N.}$$

Video Content / Details of website for further learning (if any):

<https://www.youtube.com/watch?v=6M-5yggk59U>

Important Books/Journals for further learning including the page nos.:

Bansal, R.K., "Fluid Mechanics and Hydraulics Machines", (5th edition), Laxmi publications (P) Ltd, New Delhi, 1995, Page No -581



MUTHAYAMMAL ENGINEERING COLLEGE

(An Autonomous Institution)

(Approved by AICTE, New Delhi, Accredited by NAAC & Affiliated to Anna University)
Rasipuram - 637 408, Namakkal Dist., Tamil Nadu



LECTURE HANDOUTS

L-25, 26

Robotics and
Automation

II / III

Course Name with Code : 19RAC02 Fluid Mechanics and Machinery

Course Faculty : Dr.T.Yuvaraj

Unit : III

Topic of Lecture: Applications of dimensionless parameters

Introduction : (Maximum 5 sentences)

- Dimensionless numbers are those numbers which are obtained by dividing the inertia force by viscous force or pressure force or surface tension force or elastic force.
- As this is a ratio of one force to the other force, it will be a dimensionless number

Prerequisite knowledge for Complete understanding and learning of Topic: (Max. Four important topics)

- Reynold's Number
- Euler's Number

Detailed content of the Lecture:

- 1.Reynold's model law
2. Froude's model law
3. Euler's model law
4. Weber's model law
5. Mach's model law

3.9.1 Reynold's model law: Reynold's model law is the law in which models are based on Reynold's number. Model based on Reynold's number includes:

$$= \rho_r A_r V_r = \rho_r L_r^2 V_r$$

Froude Model law: Froude Model law is the law in which the models are based on Froude number which means for dynamic similarity between the model and prototype, the Froude number for

both of them should be equal. Froude Model law is applicable when the gravity force is only predominant force which controls the flow in addition to the force of inertia.

$$V_n \dots \sqrt{\dots}$$

Weber's Model law: Weber's Model law is the law in which models are based on Weber's number which is the ratio of the square root of inertia force to surface tension force. Hence where surface tension effects predominant in addition to inertia force, the dynamic similarity between the model and prototype is obtained by equating the Weber number of the model and its prototype. Hence according to this law:

$$(W_e)_{\text{model}} = (W_e)_{\text{prototype}} \quad \text{where } W_e \text{ is Weber number} = \frac{V}{\sqrt{\sigma/\rho L}}$$

Mach Model law: Mach Model law is the law in which models are based on Mach number which is the ratio of the square root of inertia force to elastic force of a fluid. Hence where force due to elastic compression predominant in addition to inertia force, the dynamic similarity between the model and prototype is obtained by equating the Weber number of the model and its prototype.

1. A Ship is 300m long moves in seawater, whose density is 1030 kg/m³, A 1:100 model of this to be tested in a wind tunnel. The velocity of air in the wind tunnel around the model is 30m/s and the resistance of the model is 60N. Determine the velocity of ship in seawater and also the resistance of the ship in sea water. The density of air is given as 1.24 kg/m³. Take the Kinematic viscosity of seawater and air as 0.012 stokes and 0.018 stokes respectively.

For prototype,

Length	$L_p = 300\text{m}$
Fluid	= Sea water
Density of water	= 1030 kg/m ³
Kineamtic viscosity	$v_p = 0.018 \text{ stokes} = 0.018 \times 10^{-4} \text{ m}^2/\text{s}$
Let velocity of ship	= V_p
Resitance	= F_p

For Model

Length	$L_m = (1/100) \times 300$ = 3m
Velocity	$V_m = 30\text{m/s}$
Resistance	$F_m = 60\text{N}$
Density of air	$\rho_m = 1.24 \text{ kg/m}^3$
Kinematic viscosity of air	$v_m = 0.018 \text{ stokes}$ = $0.018 \times 10^{-4} \text{ m}^2/\text{s}$

For dynamic similarity between the prototype and its model, the Reynolds's number for both of them should be equal.

$$\begin{aligned} (V_p \times L_p / \nu_p) &= (V_m \times L_m / \nu_m) \text{ or } (\nu_p / \nu_m) \times (L_m / L_p) \times V_m \\ &= (0.012 \times 10^{-4} / 0.018 \times 10^{-4}) \times (3 / 300) \times 30 \\ &= 0.2 \text{ m/s.} \end{aligned}$$

Resistance = Mass X Acceleration

$$= \rho L^3 \times (V/t) = \rho L^2 \times (V/1) \times (L/t) = \rho L^2 V^2$$

Then $F_p / F_m = (\rho L^2 V^2)_p / (\rho L^2 V^2)_m = (\rho_p / \rho_m) \times (L_p / L_m)^2 \times (V_p / V_m)$

$$(\rho_p / \rho_m) = 1030 / 1.24$$

$$F_p / F_m = (1030 / 1.24) \times (300 / 3)^2 \times (0.2 / 30) = 369.17$$

$$F_p = 369.17 \times F_m$$

$$= 369.17 \times 60$$

$$= 22150.2 \text{ N.}$$

Video Content / Details of website for further learning (if any):

<https://www.youtube.com/watch?v=ckHvy731GsQ>

Important Books/Journals for further learning including the page nos.:

Bansal, R.K., "Fluid Mechanics and Hydraulics Machines", (5th edition), Laxmi publications (P) Ltd, New Delhi, 1995, Page No -581



MUTHAYAMMAL ENGINEERING COLLEGE

(An Autonomous Institution)

(Approved by AICTE, New Delhi, Accredited by NAAC & Affiliated to Anna University)
Rasipuram - 637 408, Namakkal Dist., Tamil Nadu



LECTURE HANDOUTS

L-27

Robotics and
Automation

II / III

Course Name with Code : 19RAC02 Fluid Mechanics and Machinery

Course Faculty : Dr.T.Yuvaraj

Unit : III

Topic of Lecture: Model Analysis

Introduction : (Maximum 5 sentences)

- Model is nothing but small-scale repetition of the actual structure or machine.

**Prerequisite knowledge for Complete understanding and learning of Topic:
(Max. Four important topics)**

- Model
- Actual Structure

Detailed content of the Lecture:

Model

Advantages of model analysis

The advantages of model analysis are:

1. The performance of hydraulic structure or machine can be easily predicted in advance from its model.
 2. The merits of alternative design can be predicted with the help of model testing and the most economical and safe design may be finally adopted.
- The model is the small scale replica of the actual structure or machine. The actual structure or machine is called prototype.
 - It is not necessary that the models should be smaller than the prototypes (though in most of cases it is), they may be larger than the prototype. The study of models of actual machines is called model analysis.
 - Model analysis is actually an experimental method of finding solutions of complex flow problems. The followings are the advantages of the dimensional and model analysis.

in advance, from its model.

- With the help of dimensional analysis, a relationship between the variables influencing a flow problem in terms of dimensionless parameters is obtained. This relationship helps in conducting tests on the model.
- The merits of alternative designs can be predicted with the help of model testing. The most economical and safe design may be, finally, adopted.
- The tests performed on the models can be utilized for obtaining, in advance, useful information about the performance of the prototypes only if a complete similarity exists between the model and the prototype.

Video Content / Details of website for further learning (if any):

https://www.youtube.com/watch?v=p6K0F4fFP_4

Important Books/Journals for further learning including the page nos.:

Bansal, R.K., "Fluid Mechanics and Hydraulics Machines", (5th edition), Laxmi publications (P) Ltd, New Delhi, 1995, Page No -578



MUTHAYAMMAL ENGINEERING COLLEGE

(An Autonomous Institution)

(Approved by AICTE, New Delhi, Accredited by NAAC & Affiliated to Anna University)
Rasipuram - 637 408, Namakkal Dist., Tamil Nadu



LECTURE HANDOUTS

L-28

Robotics and
Automation

II/III

Course Name with Code : 19RAC02 Fluid Mechanics and Machinery

Course Faculty : Dr. T.Yuvaraj

Unit : IV

Topic of Lecture: Impact of jets

Introduction : (Maximum 5 sentences)

- A jet is a stream of fluid that is projected into a surrounding medium, usually from some kind of a nozzle, aperture or orifice
- Jets can travel long distances without dissipating.

Prerequisite knowledge for Complete understanding and learning of Topic:

- Basic Physics and Mathematics

Detailed content of the Lecture:

Jet fluid has higher momentum compared to the surrounding fluid medium. In the case that the surrounding medium is assumed to be made up of the same fluid as the jet, and this fluid has a viscosity, the surrounding fluid is carried along with the jet in a process called entrainment.

Force Exerted By Fluid Jet On Stationary Flat Plate

The following cases of the impact of jet, i.e. the force exerted by the jet on a plate will be considered:

1. Force exerted by the jet on a stationary plate

- a) Plate is vertical to the jet
- b) Plate is inclined to the jet
- c) Plate is curve

2. Force exerted by the jet on a moving plate

- a) Plate is vertical to the jet

Fluid Dynamics 2016

Prof P.C.Swain Page 7

- b) Plate is inclined to the jet
- c) Plate is curved

Force exerted by the jet on a stationary vertical plate

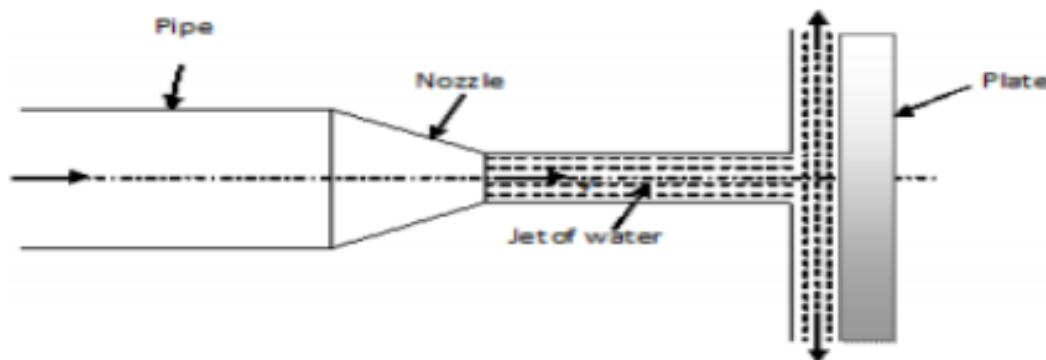

V = velocity of jet, d = diameter of the jet, a = area of x - section of the jet

The force exerted by the jet on the plate in the direction of jet.

F_x = Rate of change of momentum in the direction of force

Rate of change of momentum in the direction of force = initial momentum - final momentum / time

= mass x initial velocity - mass x final velocity / time

= mass/time (initial velocity - final velocity)

= mass/ sec x (velocity of jet before striking mass/ sec x (velocity of jet before striking - final velocity of jet after striking)

Force of Jet Impinging On An Inclined Fixed Plate:

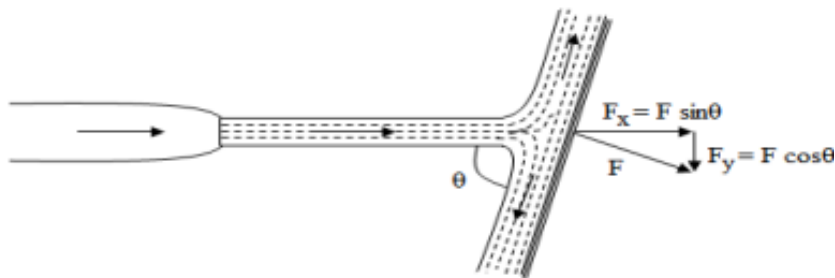

Let, θ = Angle at which the plate is inclined with the jet Force exerted by the jet on the plane

$$= \frac{waV^2}{g} \text{ KN}$$

Force exerted by the jet in a direction normal to the plate $F = \frac{waV^2 \sin \theta}{g}$

and the force exerted by the jet in the direction of flow,

$$F_x = F \sin \theta = \frac{waV^2 \sin \theta}{g} \times \sin \theta = \frac{waV^2 \sin^2 \theta}{g}$$

Similarly. force exerted by the jet in a direction normal to flow,

$$F_y = F \cos \theta = \frac{waV^2 \sin \theta}{g} \times \cos \theta$$

$$\therefore F_y = \frac{waV^2 \sin 2\theta}{2g}$$

Force Of Jet Impinging On A Moving Plate:

Consider a jet of water impinging normally on a plate. As a result of the impact of the jet, let the plate move in the direction of the jet as shown in fig-3.

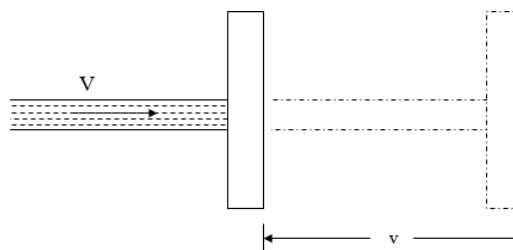

Fig-3 : Jet impinging on a moving plate

Let, v = Velocity of the plate, as a result of the impact of jet A little conversation will show

that the relative velocity of the jet with respect to the plate equal to $(V-v)$ m/s. For analysis purposes, it will be assumed that the plate is fixed and the jet is moving with a velocity of $(V-v)$ m/s. Therefore force exerted by the jet,

$$F = \text{Mass of water flowing per second} \times \text{Change of velocity}$$

$$\Rightarrow F = \frac{wa(V-v)}{g} \times [(V-v) - 0]$$

$$\Rightarrow F = \frac{wa(V-v)^2}{g} \text{ KN}$$

Web link : <https://www.slideshare.net/himanshuvastha/mechanical-engineeringfluid-mechanicsimpact-of-jets>

Important Books/Journals for further learning including the page nos.:

Bansal, R.K., "Fluid Mechanics and Hydraulics Machines", (5th edition), Laxmi publications (P) Ltd, New Delhi, 2015. , Page No - 861

LECTURE HANDOUTS

L-29

Robotics and
Automation

II/III

Course Name with Code : 19RAC02 Fluid Mechanics and Machinery

Course Faculty : Dr. T.Yuvaraj

Unit : IV

Topic of Lecture: Euler's equation - Theory of roto-dynamic machines

Introduction : (Maximum 5 sentences)

- The term 'rotodynamic machine' is used to describe machines which cause a change of total head of the fluid flowing through them by virtue of the dynamic effect they have upon the fluid.

Prerequisite knowledge for Complete understanding and learning of Topic:

- Vacuum
- Pressure, Velocity

Detailed content of the Lecture:

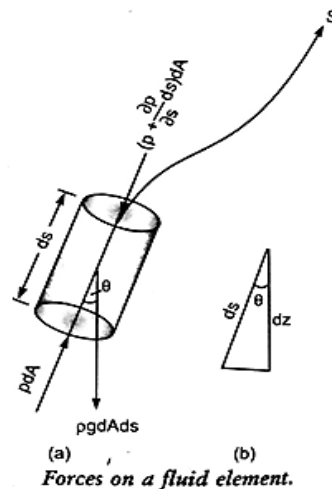

This is equation of motion in which the forces due to gravity and pressure are taken into consideration. This is derived by considering the motion of a fluid element along a stream line as

1. Pressure force pdA in the direction of low
2. Pressure force $\{p + \frac{\partial p}{\partial s} ds\} dA$ opposite to the direction of flow
3. Weight of element $gdAds$

Let θ is the angle between the direction of flow and the line of action of the weight of element.

The resultant force on the fluid element in the direction of s must be equal to the mass of fluid element \times acceleration in the direction s .

$$\begin{aligned} & p dA - \left\{ p + \frac{\partial p}{\partial s} ds \right\} dA - \rho g dA ds \cos \theta \\ & = \rho dA ds \times a_s \text{----- 1} \end{aligned}$$

Where a_s is the acceleration in the direction of s

$$\begin{aligned} a_s &= \frac{dv}{dt} \text{ where } v \text{ is a function of } s \text{ and } t. \\ &= \frac{\partial v}{\partial s} \frac{ds}{dt} + \frac{\partial v}{\partial t} \\ &= v \frac{\partial v}{\partial s} + \frac{\partial v}{\partial t} \quad \left\{ v = \frac{ds}{dt} \right\} \end{aligned}$$

If the flow is steady, $\frac{dv}{dt} = 0$

$$a_s = v \frac{\partial v}{\partial s}$$

Substituting the value of a_s in equation 1 and simplifying the equation, we get

$$\frac{-\partial p}{\partial s} ds - \rho g dA ds \cos \theta = \rho dA ds \times \frac{\partial v}{\partial s}$$

Dividing by $\rho dA ds$, $\frac{-\partial p}{\rho \partial s} - g \cos \theta = v \frac{\partial v}{\partial s}$

$$\frac{\partial p}{\rho \partial s} + g \cos \theta + v \frac{\partial v}{\partial s} = 0$$

From fig $\cos \theta = \frac{dz}{ds}$

$$\frac{1}{\rho} \frac{dp}{ds} + g \frac{dz}{ds} + v \frac{dv}{ds} = 0$$

$$\frac{dp}{\rho} + g dz + v dv = 0$$

This equation is known as Euler's equation of motion

Rotodynamic Machines

- The important element of a rotodynamic machine, in general, is a rotor consisting of a number of vanes or blades. There always exists a relative motion between the rotor vanes and the fluid. The fluid has a component of velocity and hence of momentum in a direction tangential to the rotor. While flowing through the rotor, tangential velocity and hence the momentum changes.
- The rate at which this tangential momentum changes corresponds to a tangential force on the rotor. In a turbine, the tangential momentum of the fluid is reduced and therefore work is done by the fluid to the moving rotor. But in case of pumps and compressors there

is an increase in the tangential momentum of the fluid and therefore work is absorbed by the fluid from the moving rotor.

Web link : https://nptel.ac.in/content/storage2/nptel_data3/html/mhrd/ict/text/112105206/lec1.pdf

Important Books/Journals for further learning including the page nos.:

Bansal, R.K., "Fluid Mechanics and Hydraulics Machines", (5th edition), Laxmi publications (P) Ltd, New Delhi, 2015. , Page No -261



MUTHAYAMMAL ENGINEERING COLLEGE

(An Autonomous Institution)

(Approved by AICTE, New Delhi, Accredited by NAAC & Affiliated to Anna University)
Rasipuram - 637 408, Namakkal Dist., Tamil Nadu



LECTURE HANDOUTS

L-30

Robotics and
Automation

II/III

Course Name with Code : 19RAC02 Fluid Mechanics and Machinery

Course Faculty : Dr. T.Yuvaraj

Unit : IV

Topic of Lecture: Various Efficiencies, Velocity Components At Entry And Exit Of Rotor

Introduction : (Maximum 5 sentences)

- The term efficiency may be defined as the ratio of work done to the energy supplied.

Prerequisite knowledge for Complete understanding and learning of Topic:

- Runner Power
- Water Power

Detailed content of the Lecture:

The following efficiencies are

- Hydraulic efficiency
- Mechanical efficiency
- Volumetric efficiency
- Overall efficiency

Hydraulic efficiency:

It is defined as the ratio of the power given by water to the runner of a turbine to the power supplied by the water at the inlet of the turbine.

$$\eta_h = \text{Power delivered to runner (runner power)} / \text{Power supplied at inlet (water power)}$$

Mechanical efficiency:

The ratio of the power available at the shaft of the turbine to the power delivered to the runner is defined as mechanical efficiency.

$$\eta_m = \text{Power available at the shaft (shaft power)} / \text{Power delivered to runner (runner power)}$$

Volumetric efficiency:

The ratio of the volume of the water actually striking the runner to the volume of water supplied to the turbine is defined as volumetric efficiency.

Overall efficiency:

It is defined as the ratio of the power available at the shaft of the turbine to the power supplied by the water at the inlet of the turbine.

$$\eta_o = \text{Power available at the shaft (shaft power)} / \text{Power supplied at inlet (water power)}$$

In turbomachinery, a velocity triangle or a velocity diagram is a triangle representing the various components of velocities of the working fluid in a turbomachine. Velocity triangles may be drawn for both the inlet and outlet sections of any turbomachine. The vector nature of velocity is utilized in the

triangles, and the most basic form of a velocity triangle consists of the tangential velocity, the absolute velocity and the relative velocity of the fluid making up three sides of the triangle.

Velocities involved[edit]

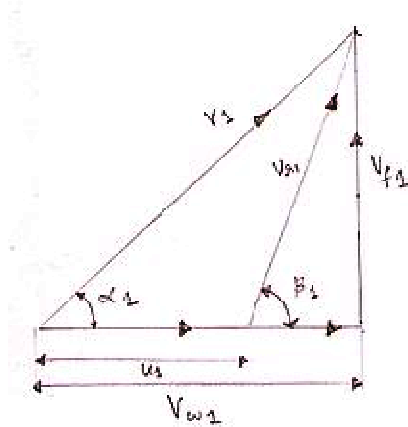

An example of a velocity triangle drawn for the inlet of a turbomachine. The "1" subscript denotes the high pressure side (inlet in case of turbines and outlet in case of pumps/compressors).

A general velocity triangle consists of the following vectors:[1][2]

V : Absolute velocity of the fluid.

U : Blade Linear velocity.

Vr: Relative velocity of the fluid after contact with rotor.

Vw: Tangential component of V (absolute velocity), called Whirl velocity.

Vf: Flow velocity (axial component in case of axial machines, radial component in case of radial machines).

The following angles are encountered during the analysis:

α : Angle made by V with the plane of the machine (usually the nozzle angle or the guide blade angle).

β : Angle of the rotor blade. Absolute angle

Web link : <https://www.slideshare.net/hitesh128/velocity-triangles-in-turbomachinery>

Important Books/Journals for further learning including the page nos.:

Bansal, R.K., "Fluid Mechanics and Hydraulics Machines", (5th edition), Laxmi publications (P) Ltd, New Delhi, 2015. , Page No -968



MUTHAYAMMAL ENGINEERING COLLEGE

(An Autonomous Institution)

(Approved by AICTE, New Delhi, Accredited by NAAC & Affiliated to Anna University)
Rasipuram - 637 408, Namakkal Dist., Tamil Nadu



LECTURE HANDOUTS

L-31

Robotics and Automation

II/III

Course Name with Code : 19RAC02 Fluid Mechanics and Machinery

Course Faculty : Dr. T.Yuvaraj

Unit : IV

Topic of Lecture: Velocity Triangle Of Centrifugal Pump

Introduction : (Maximum 5 sentences)

- As the impeller rotates, the fluid is drawn into the blade passage at the impeller eye, the centre of the impeller.
- The inlet pipe is axial and therefore fluid enters the impeller with very little whirl or tangential component of velocity and flows outwards in the direction of the blades.
- The fluid receives energy from the impeller while flowing through it and is discharged with increased pressure and velocity into the casing

Prerequisite knowledge for Complete understanding and learning of Topic:

- Relative velocity
- Velocity of Whirl

Detailed content of the Lecture:

. To convert the kinetic energy of fluid at the impeller outlet gradually into pressure energy, diffuser blades mounted on a diffuser ring are used.

The stationary blade passages so formed have an increasing cross-sectional area which reduces the flow velocity and hence increases the static pressure of the fluid. Finally, the fluid moves from the diffuser blades into the volute casing which is a passage of gradually increasing cross-section and also serves to reduce the velocity of fluid and to convert some of the velocity head into static head. Sometimes pumps have only volute casing without any diffuser.

Figure 34.1 shows an impeller of a centrifugal pump with the velocity triangles drawn at inlet and outlet. The blades are curved between the inlet and outlet radius. A particle of fluid moves along the broken curve shown in Figure

Let α_1 be the angle made by the blade at inlet, with the tangent to the inlet radius, while α_2 is the blade angle with the tangent at outlet. V_1 and V_2 are the absolute velocities of fluid at inlet and outlet respectively, while V_{r1} and V_{r2} are the relative velocities (with respect to blade velocity) at inlet and outlet respectively. Therefore,

$$\text{Work done on the fluid per unit weight} = (V_{w2}U_2 - V_{w1}U_1) / g$$

A centrifugal pump rarely has any sort of guide vanes at inlet. The fluid therefore approaches the impeller without appreciable whirl and so the inlet angle of the blades is designed to produce a right-angled velocity triangle at inlet (as shown in Fig. 34.1). At conditions other than those for which the impeller was designed, the direction of relative velocity V_r does not coincide with that of a blade. Consequently, the fluid changes direction abruptly on entering the impeller. In addition, the eddies give rise to some back flow into the inlet pipe, thus causing fluid to have some whirl before entering

the impeller. However, considering the operation under design conditions, the inlet whirl velocity V_{w1} and accordingly the inlet angular momentum of the fluid entering the impeller is set to zero. Therefore, Eq. (34.1) can be written as

$$\text{Work done on the fluid per unit weight} = \frac{V_{w2} U_2}{g}$$

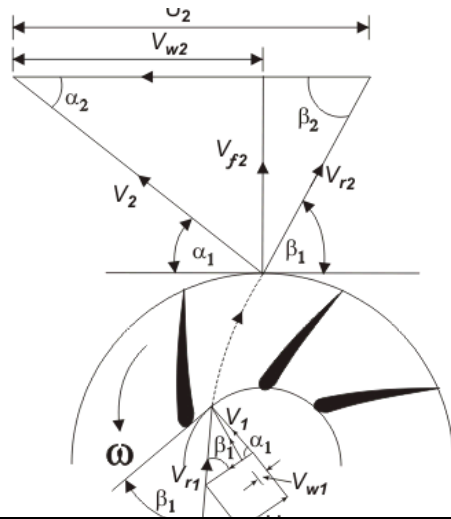

Web link : nptel.ac.in/content/storage2/courses/112104117/ui/Course_home-lec34.htm

Important Books/Journals for further learning including the page nos.:

Bansal, R.K., "Fluid Mechanics and Hydraulics Machines", (5th edition), Laxmi publications (P) Ltd, New Delhi, 2015. , Page No -597

LECTURE HANDOUTS

L-32

Robotics and
Automation

II/III

Course Name with Code : 19RAC02 Fluid Mechanics and Machinery

Course Faculty : Dr. T.Yuvaraj

Unit : IV

Topic of Lecture: Working Principle Of A Centrifugal Pump

Introduction : (Maximum 5 sentences)

- A **centrifugal pump** is a rotodynamic pump that uses a rotating impeller to increase the pressure of a fluid.
- Centrifugal pumps are commonly used to move liquids through a piping system.

Prerequisite knowledge for Complete understanding and learning of Topic:

- Suction,
- Delivery, Centrifugal Force

Detailed content of the Lecture:

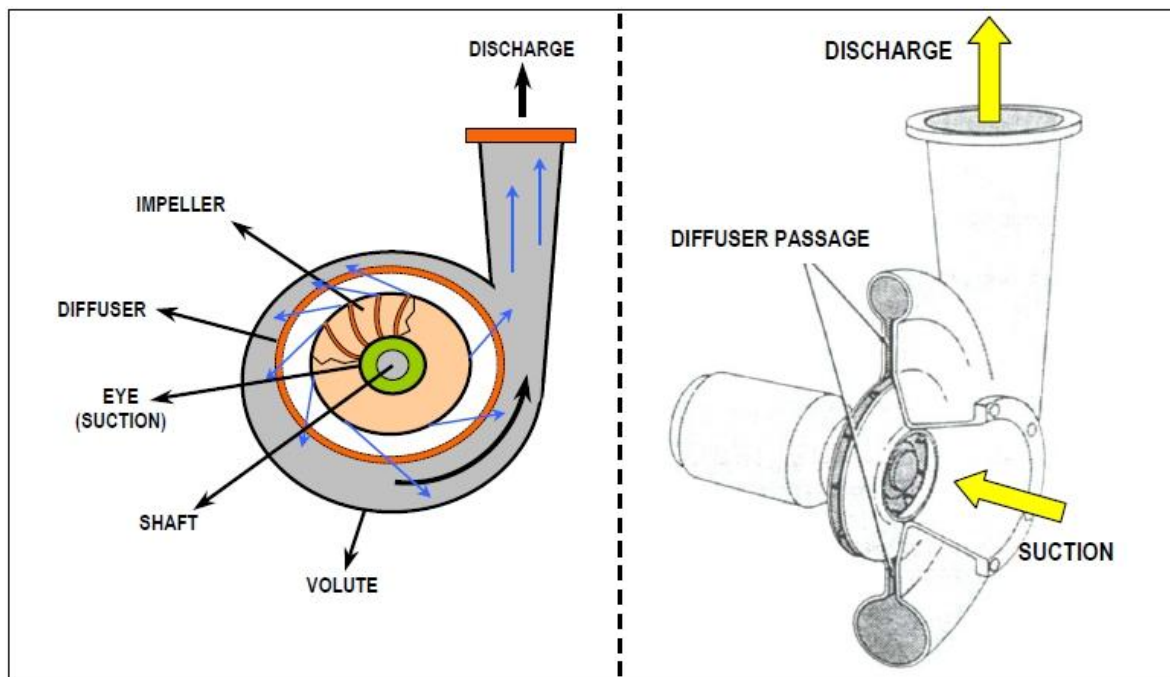

A centrifugal pump is built up of two main parts:

1. THE ROTOR (or Rotating Element).
 2. THE CASING (or Housing or Body).
- 5.2.1. The Rotor

One of the greatest advantages of a centrifugal pump is that it has very few moving parts which minimises mechanical problems and energy losses due to friction. Other than the

bearings, (and of course the driver), the only moving part in a centrifugal pump is the Rotor.

The Rotor (Rotating Element), is made up of the following main components:

1. THE IMPELLER(S) -Often called the 'Wheel(s)'. (In the centre of an impeller, is the 'EYE' which receives the inlet flow of liquid into the 'Vanes' of the impeller).
2. THE SHAFT -The impeller(s) is/are mounted on the shaft and enclosed by a casing.

5.2.2.The Impellers

These consist of wheel shaped elements containing 'Curved Vanes' at the centre of which is the liquid inlet called the 'EYE' of the impeller.The wheel(s) is/are mounted on the shaft, (together called 'the Rotating Element' which is rotated at high speed. The liquid is thrown off the outer edge of the vanes, and more liquid flows into the eye to take its place. The speed of rotation of the wheel imparts kinetic energy to the liquid in the form of velocity which will be converted to pressure (potential) energy.

There are various types of impeller depending on the duty to be performed by the pump.

1. The Open Impeller : This type consists of vanes attached to a central hub with no side wall or 'shroud'. It is used for pumping highly contaminated slurry type liquids.
2. Semi-Open Impeller : This type has the vanes attached to a wall or shroud on one side. It is used mainly for lightly contaminated and abrasive liquids and slurries.
3. Closed Impeller : This impeller has the vanes enclosed on both sides by a shroud and is the most efficient impeller, used for clean or very slightly contaminated liquids. Impellers can also be classified according to the vane curvature - i.e. 'Backward' curve used for high flow rate.

Web link : https://www.yesyen.com/centrifugal_pump_working_principle.php

Important Books/Journals for further learning including the page nos.:

Bansal, R.K., "Fluid Mechanics and Hydraulics Machines", (5th edition), Laxmi publications (P) Ltd, New Delhi, 2015. , Page No -945

LECTURE HANDOUTS

L-33

Robotics and
Automation

II/III

Course Name with Code : 19RAC02 Fluid Mechanics and Machinery

Course Faculty : Dr. T.Yuvaraj

Unit : IV

Topic of Lecture: Work done by a Impeller

Introduction : (Maximum 5 sentences)

- The working principle of centrifugal pump is done by the Impeller on the water.

Prerequisite knowledge for Complete understanding and learning of Topic:

- Absolute velocity
- Relative velocity
- Velocity of flow

Detailed content of the Lecture:

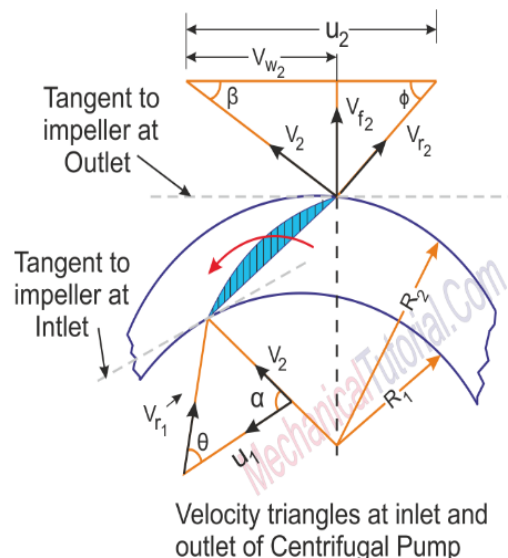

Let,

D1:Diameter of impeller at inlet= $2 \times R1$

D2:Diameter of impeller at outlet= $2 \times R2$

N:Speed of impeller in rpm

$u1$:Tangential blade velocity at inlet= $wR1=(2\pi N/60)R1$

$u2$:Tangential blade velocity at outlet= $wR2=(2\pi N/60)R2$

V:Absolute velocity

Vr:Relative velocity

Vf:Velocity of flow

Vw;Velocity of whirl

α_1 : Angle made by absolute velocity V_1 at inlet

θ : Inlet angle of vane

ϕ : Outlet angle of vane

β : Discharge angle of absolute velocity at outlet

Angular momentum = mass \times tangential velocity \times Radius

Angular momentum entering the impeller per sec = $m \cdot V_{w1} \cdot R_1$

Angular momentum leaving the impeller per sec = $m \cdot V_{w2} \cdot R_2$

Torque transmitted = rate of change of angular

momentum = $m \cdot V_{w2} \cdot R_2 - m \cdot V_{w1} \cdot R_1 = w g (V_{w2} \cdot R_2 - V_{w1} \cdot R_1)$

Since the work done in unit time is given by the product of torque and angular velocity

W.D per sec = Torque \times W

= $w g (V_{w2} \cdot R_2 - V_{w1} \cdot R_1)$

But $R_2 w = u_2$ and $R_1 w = u_1$

W.D per sec = $w g (V_{w2} u_2 - V_{w1} u_1)$

Work done by impeller per N weight of liquid per sec,

W.D = $1 g (V_{w2} u_2 - V_{w1} u_1)$

But $V_{w1} = 0$ since entry is radial

W.D per N weight per sec = $V_{w2} \cdot u_2 g$

Web link : <https://www.quora.com/p/32211/derive-an-expression-for-work-done-by-the-impeller/>

Important Books/Journals for further learning including the page nos.:

Bansal, R.K., "Fluid Mechanics and Hydraulics Machines", (5th edition), Laxmi publications (P) Ltd, New Delhi, 2015. , Page No -947



MUTHAYAMMAL ENGINEERING COLLEGE

(An Autonomous Institution)

(Approved by AICTE, New Delhi, Accredited by NAAC & Affiliated to Anna University)
Rasipuram - 637 408, Namakkal Dist., Tamil Nadu



LECTURE HANDOUTS

L-34

Robotics and
Automation

II/III

Course Name with Code : 19RAC02 Fluid Mechanics and Machinery

Course Faculty : Dr. T.Yuvaraj

Unit : IV

Topic of Lecture: Performance Curves

Introduction : (Maximum 5 sentences)

- When selecting a centrifugal pump, one should match the performance of the pump to that needed by the system.
- To do that, an engineer would refer to a pumps composite curve.

Prerequisite knowledge for Complete understanding and learning of Topic:

- Discharge
- Total head, input and output power

Detailed content of the Lecture:

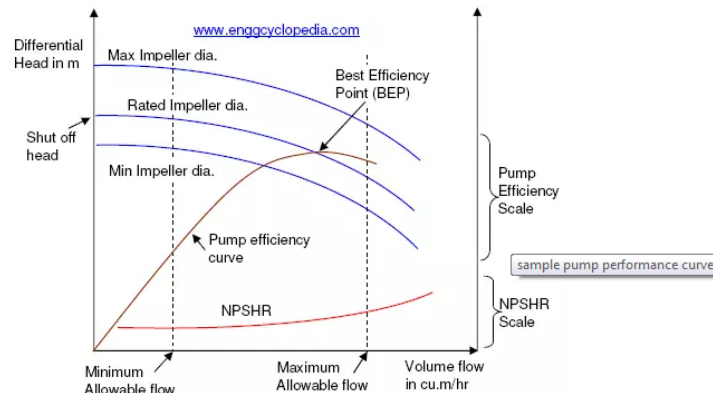

Pump performance curves are primarily used to predict the variation of the differential head across the pump, as the flow is changed. But in addition variation of efficiency, power, NPSH required etc, as the flow is changed, can also be represented on the pump performance curves by the manufacturer. It is important to be able to read and understand the pump curves for selection, testing, operation and maintenance of pumps. Typically a pump performance curve will carry information about the following points.

Variation of differential head Vs flow

This is the primary information reported in the pump performance curves and very important information regarding most of the pump calculations related to differential pressure across the pump. As shown in the sample performance curves, usually 3 curves of differential head Vs. volumetric flow

are reported.

Differential head Δh is related to differential pressure ΔP by the equation, $\Delta P = \rho g \Delta h$.

1. Curve of differential head for Rated Impeller Diameter represents the variation of differential head with volumetric flow for the impeller with rated diameter which will actually be provided with the pump.
2. Variation of differential head with volumetric flow for Maximum Impeller Diameter is plotted for the impeller with the maximum diameter that can be accommodated within the pump. This impeller can be used in case flow through the pump is increased or if more differential head is required in the future, with the same pump.
3. Variation of differential head with volumetric flow for Minimum Impeller Diameter is plotted for the impeller with minimum possible diameter. If the flow or differential head requirement is reduced in future, this impeller can be used with lower power consumption.

Although the 3 curves are plotted for a wide range of volumetric flow rates, the actual operation is to be limited within the Maximum and Minimum allowable flow rates as indicated in the sample pump performance curve. Values of the maximum and minimum flow limits are given by the pump manufacturer. The point on differential head axis (Y-axis) where each of these 3 curves terminates, represents the shut-off differential head for that particular impeller diameter. For normal intended operation, the shut-off differential head for rated impeller diameter is important. It should be noted that the pump curves for differential head Vs. volumetric flow rate are plotted for a particular liquid density. If in the future the process liquid or even just liquid density is changed, that effect has to be considered to finally determine the differential pressure. In such a case, revised volumetric flow should be calculated and located on the pump curve and corresponding differential head should be then determined from the curve for the appropriate impeller diameter. This differential head should then be used along with the changed liquid density to determine the differential pressure across the pump.

Pump Efficiency

As indicated in the sample pump performance curve above, the plot of pump efficiency against volumetric flow rate is also commonly reported on the pump performance curves. When the theoretical pumping power requirement is divided by this efficiency for the corresponding flow, the result is pump shaft power requirement. For more information on pump power calculations using efficiency, refer to EnggCyclopedia's solved sample problem. The calculated pump shaft power has to be provided by an electric motor. The efficiency curve typically has a maximum within the allowable operating range. This maximum is also known as the Best Efficiency Point (BEP) as indicated in the sample curves. The normal operation should be preferably done close to this best efficiency point for minimum power requirements. Sometimes a plot of Pump Shaft Power requirement is also done against the volumetric flow rate on the performance curves. This curve readily gives the value of power requirement for a particular flow rate.

Web link : <https://www.enggcyclopedia.com/2011/09/pump-performance-curves/>

Important Books/Journals for further learning including the page nos.:

Bansal, R.K., "Fluid Mechanics and Hydraulics Machines", (5th edition), Laxmi publications (P) Ltd, New Delhi, 2015. , Page No -978



MUTHAYAMMAL ENGINEERING COLLEGE

(An Autonomous Institution)

(Approved by AICTE, New Delhi, Accredited by NAAC & Affiliated to Anna University)
Rasipuram - 637 408, Namakkal Dist., Tamil Nadu



LECTURE HANDOUTS

L-35

Robotics and
Automation

II/III

Course Name with Code : 19RAC02 Fluid Mechanics and Machinery

Course Faculty : Dr. T.Yuvaraj

Unit : IV

Topic of Lecture: Reciprocating Pump-working Principle

Introduction : (Maximum 5 sentences)

- In a reciprocating pump, a volume of liquid is drawn into the cylinder through the suction valve on the intake stroke and is discharged under positive pressure through the outlet valves on the discharge stroke

Prerequisite knowledge for Complete understanding and learning of Topic:

- Forward motion
- Retract motion

Detailed content of the Lecture:

The discharge from a reciprocating pump is pulsating and changes only when the speed of the pump is changed. This is because the intake is always a constant volume. Often an air chamber is connected on the discharge side of the pump to provide a more even flow by evening out the pressure surges. Reciprocating pumps are often used for sludge and slurry.

One construction style of a reciprocating pump is the direct-acting steam pump. These consist of a steam cylinder end in line with a liquid cylinder end, with a straight rod connection between the steam piston and the pump piston or plunger. These pistons are double acting which means that each side pumps on every stroke.

Another construction style is the power pump which converts rotary motion to low speed reciprocating motion using a speed reducing gear. The power pump can be either single or double-acting. A single-acting design discharges liquid only on one side of the piston or plunger. Only one suction and one discharge stroke per revolution of the crankshaft can occur. The double-acting design takes suction and discharges on both sides of the piston resulting in two suctions and discharges per crankshaft revolution. Power pumps are generally very efficient and can develop high pressures. These pumps do however tend to be expensive.

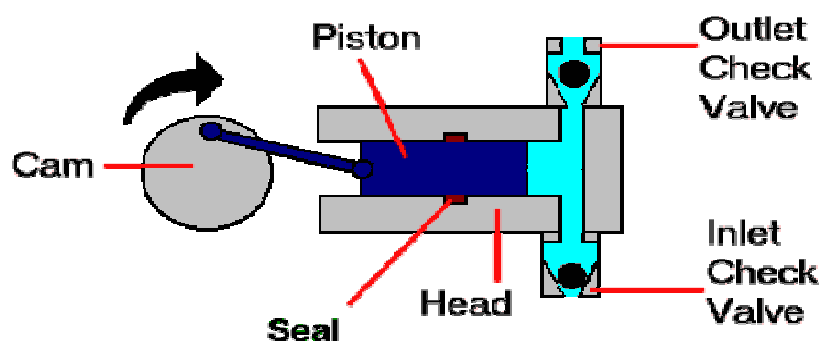

To 'Reciprocate' means to Move Backwards and Forwards'. A 'Reciprocating' pump therefore, is one with a forward and backward operating action. The most simple reciprocating pump is the 'Bicycle Pump', which everyone at some time or other will have used to re-inflate their bike tyres. The name 'Bicycle PUMP' is not really the correct term because it causes compression. It is essentially a hand operated compressor and consists of a metal or plastic tube called a 'Cylinder' inside of which a hand-operated rod or 'Piston' is pushed back and forth. On the piston end, a special leather or rubber cup - shaped attachment is fixed. When the piston is pushed forward, (this is called a 'Stroke'), the cup flexes against the cylinder walls giving a seal to prevent air passing to the other side. As the pump handle is pushed, air pressure builds up ahead of the cup and is forced discharged) into the tyre through the tyre valve which also prevents air escaping when the pump is disconnected or when the piston is pulled back. When the pump handle is pulled back, (called the 'Suction' stroke), the cup relaxes and the backward motion causes air to pass between it and the cylinder wall to replace the air pushed into the tyre. This reciprocating action is repeated until the tyre is at the required pressure

Web link : <https://www.theengineerspost.com/reciprocating-pump/>

Important Books/Journals for further learning including the page nos.:

Bansal, R.K., "Fluid Mechanics and Hydraulics Machines", (5th edition), Laxmi publications (P) Ltd, New Delhi, 2015. , Page No -993



MUTHAYAMMAL ENGINEERING COLLEGE

(An Autonomous Institution)

(Approved by AICTE, New Delhi, Accredited by NAAC & Affiliated to Anna University)
Rasipuram - 637 408, Namakkal Dist., Tamil Nadu



LECTURE HANDOUTS

L-36

Robotics and
Automation

II/III

Course Name with Code : 19RAC02 Fluid Mechanics and Machinery

Course Faculty : Dr. T.Yuvaraj

Unit : IV

Topic of Lecture: Rotary Pump Classification

Introduction : (Maximum 5 sentences)

- A positive displacement pump. For each revolution of the pump, a fixed volume of fluid is moved regardless of the resistance against which the pump is pushing.

Prerequisite knowledge for Complete understanding and learning of Topic:

- Pump Principle
- Suction, Meshing of Gears

Detailed content of the Lecture:

Rotary pumps are useful for pumping oil and other liquids of high viscosity. In the engine room, rotary pumps are used for handling lube oil and fuel oil and are suitable for handling liquids over a wide range of viscosities. Rotary pumps are designed with very small clearances between rotating parts and stationary parts to minimize leakage (slippage) from the discharge side back to the suction side. Rotary pumps are designed to operate at relatively low speeds to maintain these clearances. The operation at higher speeds causes erosion and excessive wear which result in increased clearances with a subsequent decrease in pumping capacity. Classification of the rotary pumps is generally based on the types of rotating element.

Gear pump – The simple gear pump has two spur gears that mesh together and revolve in opposite directions. One is the driving gear, and the other is the driven gear. Clearances between the gear teeth (outside diameter of the gear) and the casing and between the end face and the casing are only a few thousandths of an inch. As the gears turn, they unmesh and liquid flows into the pockets that are vacated by the meshing gear teeth. This creates the suction that draws the liquid into the pump. The liquid is then carried along in the pockets formed by the gear teeth and the casing. On the discharge side, the liquid is displaced by the meshing of the gears and forced out through the discharge side of the pump.

Rotary vane pumps – The rotary vane pump has a cylindrically-bored housing with a suction inlet on one side and a discharge outlet on the other side. A rotor (smaller in diameter than the cylinder) is driven about an axis that is placed above the center line of the cylinder to provide minimum clearance between the rotor and cylinder at the top and maximum clearance at the bottom. The rotor carries vanes (which move in and out as the rotor rotates) to maintain sealed spaces between the rotor and the cylinder wall. The vanes trap liquid on the suction side and carry it to the discharge side, where contraction of the space expels liquid through the discharge line. The vanes slide on slots in the rotor. Vane pumps are used for lube oil service and transfer,

tank stripping, bilge, and in general, for handling lighter viscous liquids.

Screw pump – There are several different types of screw pumps. The differences between the various types are the number of intermeshing screws and the screw pitch. Screw pumps are used aboard ship to pump fuel and lube oil and to supply pressure to the hydraulic system. In the double-screw pump, one rotor is driven by the drive shaft and the other by a set of timing gears. In the triple-screw pump, a central rotor meshes with two idler rotors. In the screw pump, liquid is trapped and forced through the pump by the action of rotating screws. As the rotor turns, the liquid flows in between the threads at the outer end of each pair of screws. The threads carry the liquid along within the housing to the center of the pump where it is discharged. Most screw pumps are now equipped with mechanical seals. If the mechanical seal fails, the stuffing box has the capability of accepting two rings of conventional packing for emergency use.

Web link : <https://www.wartsila.com/encyclopedia/term/rotary-pump>

Important Books/Journals for further learning including the page nos.:

Bansal, R.K., "Fluid Mechanics and Hydraulics Machines", (5th edition), Laxmi publications (P) Ltd, New Delhi, 2015. , Page No -989



MUTHAYAMMAL ENGINEERING COLLEGE

(An Autonomous Institution)

(Approved by AICTE, New Delhi, Accredited by NAAC & Affiliated to Anna University)
Rasipuram - 637 408, Namakkal Dist., Tamil Nadu



LECTURE HANDOUTS

L-37

Robotics and
Automation

II/III

Course Name with Code : 19RAC02 Fluid Mechanics and Machinery

Course Faculty : Dr. T.Yuvaraj

Unit : V

Topic of Lecture: Classification of Turbines, Heads and Velocities

Introduction : (Maximum 5 sentences)

Turbine:

- Turbine is defined as the hydraulic machine which converts Hydraulic Energy in to mechanical energy

Prerequisite knowledge for Complete understanding and learning of Topic:

- Basic Physics and Mathematics

Detailed content of the Lecture:

Classification of turbines:

1. According to the type of energy at inlet
a. impulse turbine **b.** reaction turbine
2. According to the direction of flow through runner
a. tangential flow turbine **b.** radial flow turbine **c.** Axial flow turbine **d.** Mixed flow turbine.
3. According to the head at the inlet of turbine
a. High speed turbine **b.** Medium speed turbine **c.** low head turbine
4. According to the specific speed of the turbine
a. Low specific speed turbine **b.** Medium specific speed turbine **c.** High specific speed turbine

Reaction turbine:

At the inlet of a turbine if the energy available is kinetic energy and pressure energy then the turbines is said to be a reaction turbine.

Example: Thomson, Francis, Propeller, Kaplan

Impulse turbine:

Turbine if the energy available at the inlet of the turbine is only kinetic energy then the turbine is impulse type.

Example: Pelton wheel.

Axial flow turbines:

The flows of water through the runner along the direction parallel to the axis of rotation of the turbine

Example: Kaplan turbine, Propeller turbine

Tangential flow turbine:

The loss of water along the tangent of the runner.

Example: Pelton turbine

Radial flow turbine:

The water flows in the radial direction through runner

Example: Thomson turbine

Inward radial flow reaction turbine:

If the water flows from outwards to inwards through the runner, the turbine is known as inward radial flow reaction turbine. Here the outer diameter of the runner is inlet diameter whereas the inner diameter of the runner is outlet diameter.

Outward radial flow reaction turbine:

If the water flows from inwards to outwards through the runner, the turbine is called as outward radial flow reaction turbine. Here the outer diameter of the runner is outlet diameter whereas the inner diameter of the runner is inlet diameter.

Gross head of a turbine:

The difference between head race level and tail race level is known as Gross Head.

Net head of a turbine:

It is also called effective head and is defined as the head available at the inlet of the turbine.

$$H = H_g - h_f$$

Web link : <https://www.slideshare.net/IshantGautam/classification-of-hydraulic-turbines>

Important Books/Journals for further learning including the page nos.:

Bansal, R.K., "Fluid Mechanics and Hydraulics Machines", (5th edition), Laxmi publications (P) Ltd, New Delhi, 2015. , Page No -853

LECTURE HANDOUTS

L-38

Robotics and
Automation

II/III

Course Name with Code : 19RAC02 Fluid Mechanics and Machinery

Course Faculty : Dr. T.Yuvaraj

Unit : V

Topic of Lecture: Velocity Triangle

Introduction : (Maximum 5 sentences)

- In turbomachinery, a velocity triangle or a velocity diagram is a triangle representing the various components of velocities of the working fluid in a turbomachine. Velocity triangles may be drawn for both the inlet and outlet sections of any turbomachine.

Prerequisite knowledge for Complete understanding and learning of Topic:

- Basic Physics and Mathematics

Detailed content of the Lecture:

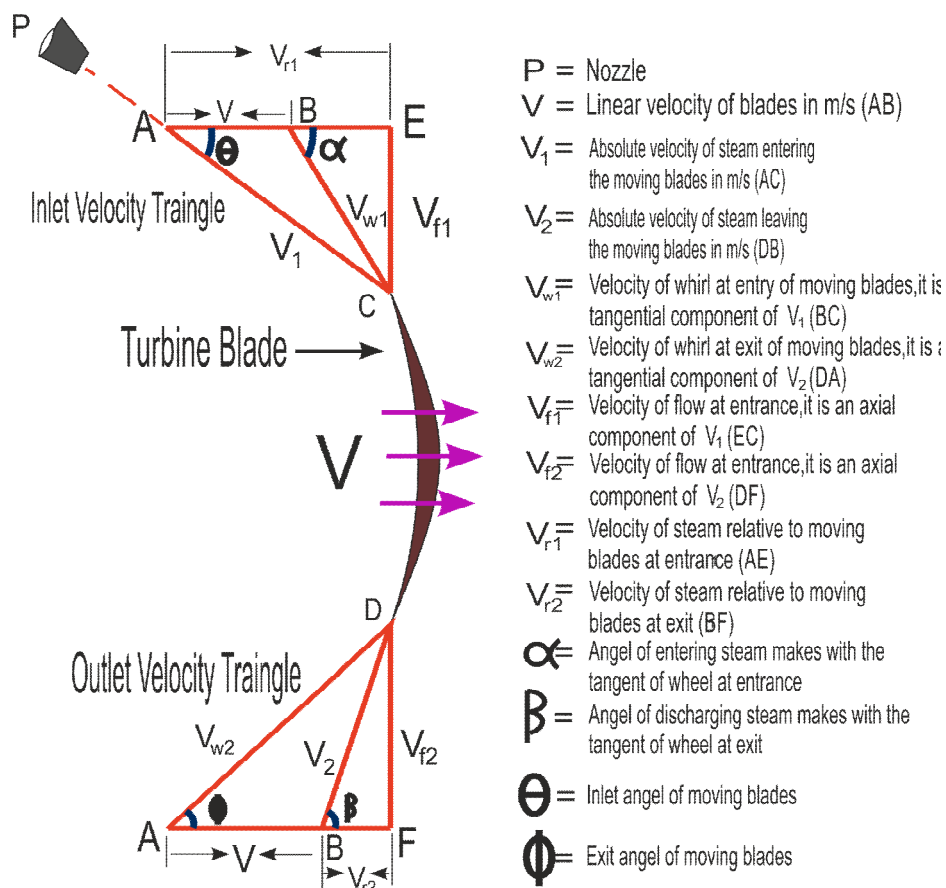

A general velocity triangle consists of the following vectors:[1][2]

V : Absolute velocity of the fluid.

U : Blade Linear velocity.

V_r : Relative velocity of the fluid after contact with rotor.

V_w : Tangential component of V (absolute velocity), called Whirl velocity.

V_f : Flow velocity (axial component in case of axial machines, radial component in case of radial machines).

The following angles are encountered during the analysis:

α : Angle made by V with the plane of the machine (usually the nozzle angle or the guide blade angle).

β : Angle of the rotor blade. Absolute angle

Web link : <https://www.slideshare.net/sohannishan/velocity-triangle-for-moving-blade-of-an-impulse-turbine>

Important Books/Journals for further learning including the page nos.:

Bansal, R.K., "Fluid Mechanics and Hydraulics Machines", (5th edition), Laxmi publications (P) Ltd, New Delhi, 2015. , Page No -857

LECTURE HANDOUTS

L-39

Robotics and
Automation

II/III

Course Name with Code : 19RAC02 Fluid Mechanics and Machinery

Course Faculty : Dr. T.Yuvaraj

Unit : V

Topic of Lecture: Axial, Radial and Mixed Flow turbines

Introduction : (Maximum 5 sentences)

- According to the direction of flow or flow path of liquid through the runner of the turbine, turbine is classified into Axial, radial, mixed and tangential flow turbine

Prerequisite knowledge for Complete understanding and learning of Topic:

- Basic Physics and Mathematics

Detailed content of the Lecture:

Axial flow turbine-liquid flows parallel to the rotational axis of the shaft of the turbine. An example includes Kaplan Turbine

Radial flow turbine-liquid flows perpendicular to the rotational axis of the shaft of the turbine. An example includes Francis turbine

Mixed flow turbine-liquid enters in a radial direction and exits in axial direction. An example includes Modern Francis turbine

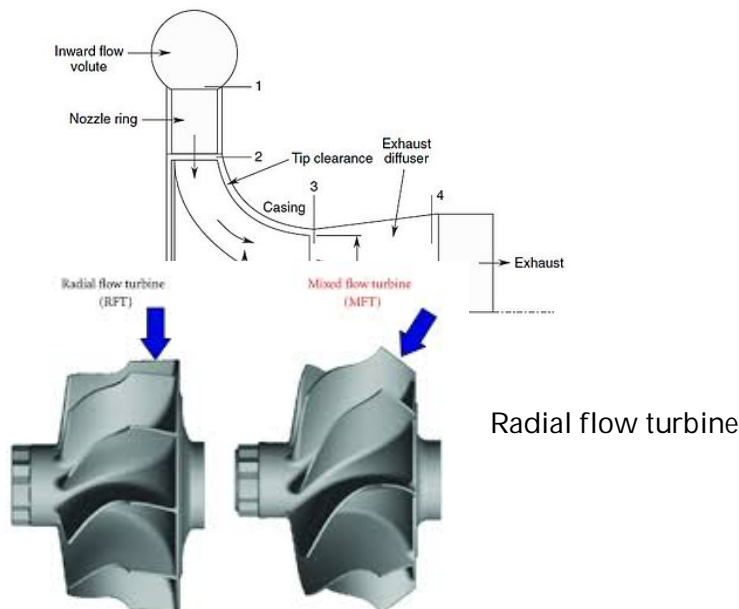



Mixed flow

turbine

Axial flow

Web link : https://nptel.ac.in/content/storage2/nptel_data3/html/mhrd/ict/text/101101058/lec35.pdf

Important Books/Journals for further learning including the page nos.:

Bansal, R.K., "Fluid Mechanics and Hydraulics Machines", (5th edition), Laxmi publications (P) Ltd, New Delhi, 2015. , Page No -905



LECTURE HANDOUTS

L-40

Robotics and
Automation

II/III

Course Name with Code : 19RAC02 Fluid Mechanics and Machinery

Course Faculty : Dr. T.Yuvaraj

Unit : V

Topic of Lecture: Pelton wheel

Introduction : (Maximum 5 sentences)

- Pelton Turbine is a Tangential flow impulse turbine in which the pressure energy of water is converted into kinetic energy to form high speed water jet and this jet strikes the wheel tangentially to make it rotate. It is also called as Pelton Wheel.

Prerequisite knowledge for Complete understanding and learning of Topic:

- Basic Physics and Mathematics

Detailed content of the Lecture:

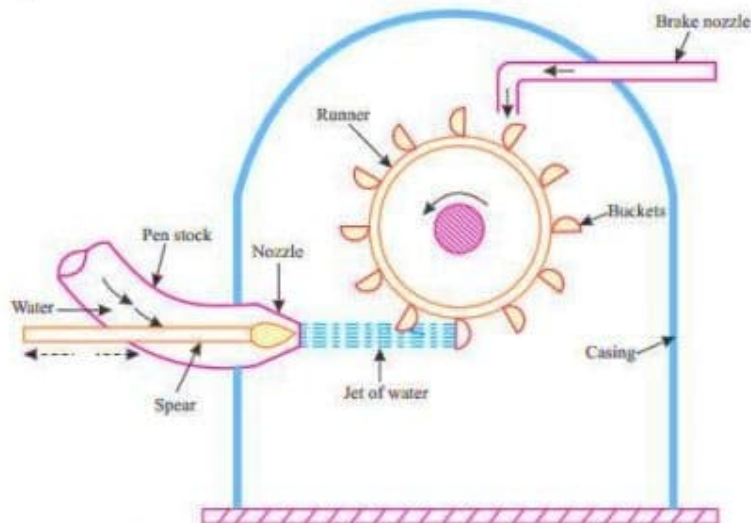

1. Nozzle and Flow Regulating Arrangement
2. Runner and Buckets
3. Casing
4. Braking Jet

Working of Pelton Turbine

The working of Pelton turbine is as follows:

- The water is transferred from the high head source through a long conduit called Penstock.
- Nozzle arrangement at the end of penstock helps the water to accelerate and it flows out as a high speed jet with high velocity and discharge at atmospheric pressure.
- The jet will hit the splitter of the buckets which will distribute the jet into two halves of bucket and the wheel starts revolving.
- The kinetic energy of the jet is reduced when it hits the bucket and also due to spherical shape of buckets the directed jet will change its direction and takes U-turn and falls into tail race.

Following are the aspects to be considered while designing the Pelton wheel turbine.

1. Velocity of jet
2. Velocity of wheel
3. Angle of deflection of jet
4. Mean diameter of the wheel
5. Jet ratio
6. Bucket dimensions
7. Number of jets
8. Number of buckets

1. Velocity of Jet

The velocity of the jet at inlet is given by

$$V_1 = C_v \sqrt{2gH}$$

Where C_v = co-efficient of velocity = 0.98 or 0.99.

H = Net head on turbine.

2. Velocity of Wheel

The velocity of wheel (u) is given by

$$u = \phi \sqrt{2gH}$$

Where, ϕ = speed ratio = 0.43 to 0.48

3. Angle of Deflection of Jet

The angle of deflection of jet after striking the buckets is taken as 165° if no deflection angle is given.

4. Mean Diameter of The Wheel

The mean diameter or the pitch diameter D of the pelton turbine is given by

$$u = \frac{\pi DN}{60} \text{ .or. } D = \frac{60u}{\pi N}$$

5. Jet Ratio

It is defined as the ratio of the pitch diameter (D) of the pelton turbine to the diameter of the jet (d). It is denoted by m and is given as

$$m = D/d$$

Jet ratio(m) is lies between 11 to 16 for maximum hydraulic efficiency. however, In most of the cases it is taken as 12.

6. Bucket Dimensions

Buckets dimensions are designed in such a way that its breadth should be 3 to 4 times of diameter of jet, length should be 2 to 3 times of diameter of jet and thickness should be 0.8 to 1.2 times the diameter of jet.

7. Number of Jets

It is obtained by dividing the total rate of flow through the turbine by the rate of flow of water through a single jet.

In general, Number of jets are limited to two in case of vertical runner and six in case of horizontal runner.

8. Number of Buckets

The number of buckets (z) on a runner is given by

$$Z = 15 + \frac{D}{2d} = 15 + 0.5m$$

Where, D = Pitch diameter

d = Diameter of Jet

m = jet ratio

Web link : <https://learnmechanical.com/pelton-wheel-turbine/>

Important Books/Journals for further learning including the page nos.:

Bansal, R.K., "Fluid Mechanics and Hydraulics Machines", (5th edition), Laxmi publications (P) Ltd, New Delhi, 2015. , Page No -856



MUTHAYAMMAL ENGINEERING COLLEGE

(An Autonomous Institution)

(Approved by AICTE, New Delhi, Accredited by NAAC & Affiliated to Anna University)
Rasipuram - 637 408, Namakkal Dist., Tamil Nadu



LECTURE HANDOUTS

L-41

Robotics and
Automation

II/III

Course Name with Code : 19RAC02 Fluid Mechanics and Machinery

Course Faculty : Dr. T.Yuvaraj

Unit : V

Topic of Lecture: Francis Turbine

Introduction : (Maximum 5 sentences)

- Francis Turbine is a combination of both impulse and reaction turbine, where the blades rotate using both reaction and impulse force of water flowing through them producing electricity more efficiently. Francis turbine is used for the production of electricity in hydro power stations.

Prerequisite knowledge for Complete understanding and learning of Topic:

- Basic Physics and Mathematics

Detailed content of the Lecture:

Main Components of Francis Turbine

The major components of Francis turbine are

1. Spiral Casing

Spiral casing is the inlet medium of water to the turbine. The water flowing from the reservoir or dam is made to pass through this pipe with high pressure. The blades of the turbines are circularly placed, which mean the water striking the turbines blades should flow in the circular axis for efficient striking. So the spiral casing is used, but due to circular movement of the water, it loses its pressure. To maintain the same pressure the diameter of the casing is gradually reduced, so as to maintain the pressure uniform, thus uniform momentum or velocity striking the runner blades.

2. Stay Vanes

Stay vanes and guide vanes guides the water to the runner blades. Stay vanes remain stationary at their position and reduces the swirling of water due to radial flow, as it enters the runner blades. Thus making turbine more efficient.

3. Guide Vanes

Guide vanes are not stationary, they change their angle as per the requirement to control the angle of striking of water to turbine blades to increase the efficiency. They also regulate the flow rate of water into the runner blades thus controlling the power output of a turbine according to the load on the turbine.

4. Runner Blades

The performance and efficiency of the turbine is dependent on the design of the runner blades. In a Francis turbine, runner blades are divided into 2 parts. The lower half is made in the shape of small bucket so that it uses the impulse action of water to rotate the turbine.

The upper part of the blades use the reaction force of water flowing through it. These two forces together makes the runner to rotate.

5. Draft Tube

The pressure at the exit of the runner of Reaction Turbine is generally less than atmospheric pressure. The water at exit cannot be directly discharged to the tail race. A tube or pipe of gradually increasing area is used for discharging water from the exit of turbine to the tail race.

This tube of increasing area is called Draft Tube. One end of the tube is connected to the outlet of runner while the other end is sub-merged below the level of water in the tail-race.

How Does a Francis Turbine Work?

The water is allowed to enter the spiral casing of the turbine, which lead the water through the stay vanes and guide vanes. The spiral case is kept in decreasing diameter so as to maintain the flow pressure. The stay vanes being stationary at their place, removes the swirls from the water, which are generated due to flow through spiral casing and tries it to make the flow of water more linear to be deflected by adjustable guide vanes.

The angle of guide vanes decides the angle of attack of water at the runner blades thus make sure the output of the turbine. The runner blades are stationary and can-not pitch or change their angle so it's all about the guide vanes which controls the power output of a turbine.

The performance and efficiency of the turbine is dependent on the design of the runner blades. In a Francis turbine, runner blades are divided into 2 parts. The lower half is made in the shape of small bucket so that it uses the impulse action of water to rotate the turbine.

The upper part of the blades use the reaction force of water flowing through it. Thus runner blades make use of both pressure energy and kinetic energy of water and rotates the runner in most efficient way.

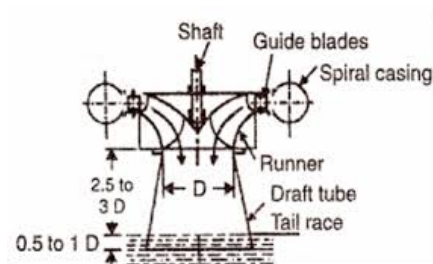

Web link : <https://theconstructor.org/practical-guide/francis-turbines-components-application/2900/>

Important Books/Journals for further learning including the page nos.:

Bansal, R.K., "Fluid Mechanics and Hydraulics Machines", (5th edition), Laxmi publications (P) Ltd, New Delhi, 2015. , Page No -895



MUTHAYAMMAL ENGINEERING COLLEGE

(An Autonomous Institution)

(Approved by AICTE, New Delhi, Accredited by NAAC & Affiliated to Anna University)
Rasipuram - 637 408, Namakkal Dist., Tamil Nadu



LECTURE HANDOUTS

L-42

Robotics and
Automation

II/III

Course Name with Code : 19RAC02 Fluid Mechanics and Machinery

Course Faculty : Dr. T.Yuvaraj

Unit : V

Topic of Lecture: Kaplan turbine

Introduction : (Maximum 5 sentences)

- Kaplan Turbine works on the principle of axial flow reaction. In axial flow turbines, the water flows through the runner along the direction parallel to the axis of rotation of the runner. The water at the inlet of the turbine possesses both kinetic energy as well as pressure energy for effective rotation the blades in a hydro-power station.

Prerequisite knowledge for Complete understanding and learning of Topic:

- Basic Physics and Mathematics

Detailed content of the Lecture:

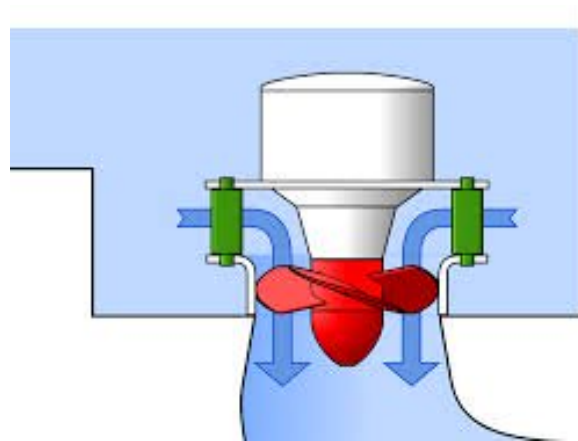

Main Components of Kaplan Turbine

The main parts of Kaplan Turbine are,

1. Scroll Casing

It is a spiral type of casing that has decreasing cross section area. The water from the penstocks enters the scroll casing and then moves to the guide vanes where the water turns through 90° and flows axially through the runner. It protects the runner, runner blades guide vanes and other internal parts of the turbine from an external damage.

2. Guide Vane Mechanism

It is the only controlling part of the whole turbine, which opens and closes depending upon

the demand of power requirement. In case of more power output requirements, it opens wider to allow more water to hit the blades of the rotor and when low power output requires it closes itself to cease the flow of water. If guide vanes is absent than the turbine can not work efficiently and its efficiency decreases.

3. Draft Tube

The pressure at the exit of the runner of Reaction Turbine is generally less than atmospheric pressure. The water at exit cannot be directly discharged to the tail race. A tube or pipe of gradually increasing area is used for discharging water from the exit of turbine to the tail race. This tube of increasing area is called Draft Tube. One end of the tube is connected to the outlet of runner while the other end is sub-merged below the level of water in the tail-race.

4. Runner Blades

The heart of the component in kaplan turbine are its runner blades, as it the rotating part which helps in production of electricity. Its shaft is connected to the shaft of the generator. The runner of the this turbine has a large boss on which its blades are attached and the the blades of the runner is adjustable to an optimum angle of attack for maximum power output. The blades of the Kaplan turbine has twist along its length

Working Procedure of Kaplan Turbine

The water coming from the pen-stock is made to enter the scroll casing. The scroll casing is made in the required shape that the flow pressure is not lost. The guide vanes direct the water to the runner blades. The vanes are adjustable and can adjust itself according to the requirement of flow rate. The water takes a 90 degree turn, so the direction of the water is axial to that of runner blades.

The runner blades start to rotate as the water strikes due to reaction force of the water. The runner blades has twist along its length in order to have always optimum angle of attack for all cross section of blades to achieve greater efficiency.

From the runner blades, the water enters into the draft tube where its pressure energy and kinetic energy decreases. Kinetic energy is gets converted into pressure energy results in increased pressure of the water.

The rotation of the turbine is used to rotate the shaft of generator for electricity production.

Web link : <https://theconstructor.org/practical-guide/kaplan-turbine-component-working/2904/>

Important Books/Journals for further learning including the page nos.:

Bansal, R.K., "Fluid Mechanics and Hydraulics Machines", (5th edition), Laxmi publications (P) Ltd, New Delhi, 2015. , Page No -877



MUTHAYAMMAL ENGINEERING COLLEGE

(An Autonomous Institution)

(Approved by AICTE, New Delhi, Accredited by NAAC & Affiliated to Anna University)
Rasipuram - 637 408, Namakkal Dist., Tamil Nadu



LECTURE HANDOUTS

L-43

Robotics and
Automation

II/III

Course Name with Code : 19RAC02 Fluid Mechanics and Machinery

Course Faculty : Dr. T.Yuvaraj

Unit : V

Topic of Lecture: Turbine Work done problems and Performance curves

Introduction : (Maximum 5 sentences)

- Using the given specifications, the work done by the turbines should be found out.

Prerequisite knowledge for Complete understanding and learning of Topic:

- Basic Physics and Mathematics

Detailed content of the Lecture:

A Pelton wheel is to be designed for the following specifications:

Shaft power = 11, 772 kW; Head = 380 metres; Speed = 750 r.p.m; overall efficiency = 86 %;

Jet diameter is not to exceed one – sixth of the wheel diameter. Determine: (i). the wheel diameter,

(ii). the number of jets required and (iii). Diameter of the jet. Take $K_{v1} = 0.985$ and $K_{u1} = 0.45$.

Solution:

Shaft power, S.P = 11, 772 kW

Head, H = 380 m.

Speed, N = 750 r.p.m

Overall efficiency, $\eta_0 = 86\%$ or 0.86

$$\text{Ratio of jet dia to wheel dia} = \frac{d}{D} = \frac{1}{6}$$

Co-efficient of velocity, $K_{v1} = C_v = 0.985$

Speed ratio, $K_{u1} = 0.45$

Velocity of jet, $V_1 = C_v \sqrt{2gH} = 0.985 \sqrt{2 \times 9.81 \times 380} = 85.05 \text{ m/s}$

The velocity of wheel, $u = u_1 = u_2$
 $= \text{Speed ratio} \times \sqrt{2gH} = 0.45 \times \sqrt{2 \times 9.81 \times 380} = 38.85 \text{ m/s}$

But $u = \frac{\pi D N}{60}$

$\therefore 38.85 = \frac{\pi D N}{60}$

$$D = \frac{60 \times 38.85}{\pi \times N} = \frac{60 \times 38.85}{\pi \times 750} = 0.989 \text{ m.}$$

But $\frac{d}{D} = \frac{1}{6}$

$$\therefore \text{Dia of jet, } d = \frac{1}{6} \times D = \frac{0.989}{6} = 0.165\text{m. Answer}$$

Discharge of on jet, $q = \text{Area of jet} \times \text{Velocity of jet}$

$$= \frac{\pi}{4} d^2 \times V_1 = \frac{\pi}{4} (.165)^2 \times 85.05\text{m}^3 / \text{s} = 1.818\text{m}^3 / \text{s}$$

$$\text{Now } \eta_0 = \frac{S.P}{W.P} = \frac{11772}{\frac{pg \times Q \times H}{1000}}$$

$$0.86 = \frac{11772 \times 1000}{1000 \times 9.81 \times Q \times 380} \quad \text{where } Q = \text{Total discharge}$$

$$\therefore \text{Total discharge, } Q = \frac{11772 \times 1000}{1000 \times 9.81 \times 380 \times 0.86} = 3.672\text{m}^3 / \text{s}$$

$$\therefore \text{Number of jets} = \frac{\text{Total discharge}}{\text{Discharge of one jet}}$$

$$= \frac{Q}{q} = \frac{3.672}{1.818} = 2 \text{ jets. Answer.}$$

An inward flow reaction turbine has external has external and internal diameters as 1m and 0.5m respectively. The velocity of flow through the runner is constant and is equal to 1.5 m/s. Determine: (i) Discharge through the runner and (ii) Width of the turbine at outlet if the width of the turbine at inlet = 200 mm.

Solution:

$$\text{External diameter of turbine, } D_1 = 1\text{m}$$

$$\text{Internal diameter of turbine, } D_2 = 0.5\text{ m}$$

$$\text{Velocity of flow at inlet and outlet, } V_{f_1} = V_{f_2} = 1.5\text{m} / \text{s}$$

$$\text{Width of turbine at inlet, } B_1 = 200\text{ mm} = 0.20\text{ m}$$

$$\text{Let the width at outlet} = B_2$$

Using equation for discharge,

$$Q = \pi D_1 B_1 \times V_{f_1} = \pi \times 1 \times 0.20 \times 1.5 = 0.9425\text{m}^3 / \text{s}$$

$$\text{Also } \pi D_1 B_1 V_{f_1} = \pi D_2 B_2 V_{f_2}$$

$$\text{or } D_1 B_1 = D_2 B_2 \quad (\because \pi V_{f_1} = \pi V_{f_2})$$

$$B_2 = \frac{D_1 \times B_1}{D_2} = \frac{1 \times 0.20}{.05} = 0.40\text{m} = 400\text{mm. Answer}$$

Web link : <https://theconstructor.org/practical-guide/kaplan-turbine-component-working/2904/>

Important Books/Journals for further learning including the page nos.:

Bansal, R.K., "Fluid Mechanics and Hydraulics Machines", (5th edition), Laxmi publications (P) Ltd, New Delhi, 2015. , Page No -862



MUTHAYAMMAL ENGINEERING COLLEGE

(An Autonomous Institution)

(Approved by AICTE, New Delhi, Accredited by NAAC & Affiliated to Anna University)
Rasipuram - 637 408, Namakkal Dist., Tamil Nadu



LECTURE HANDOUTS

L-44

Robotics and
Automation

II/III

Course Name with Code : 19RAC02 Fluid Mechanics and Machinery

Course Faculty : Dr. T.Yuvaraj

Unit : V

Topic of Lecture: Draft Tube and Specific Speed

Introduction : (Maximum 5 sentences)

A tube of gradually increasing area is used for discharging water from turbine exit to tail race is called a draft tube.

Prerequisite knowledge for Complete understanding and learning of Topic:

- Basic Physics and Mathematics

Detailed content of the Lecture:

The function of draft tube:

1. It is a passage for water discharge
2. for easy inspection of turbine which may be placed above the tail race.
3. The kinetic energy rejected at the outlet of the turbine is converted into useful pressure energy

The various type of draft tubes:

- a. conical tube
- b. Simple elbow tubes
- c. Elbow draft tubes with circular inlet and rectangular outlet

1. **Conical diffuser or straight divergent tube**-This type of draft tube consists of a conical diffuser with half angle generally less than equal to 10° to prevent flow separation. It is usually employed for low specific speed, vertical shaft francis turbine. Efficiency of this type of draft tube is 90%

2. **Simple elbow type draft Tube**-It consists of an extended elbow type tube. Generally, used when turbine has to be placed close to the tail-race. It helps to cut down the cost of excavation and the exit diameter should be as large as possible to recover kinetic energy at the outlet of runner. Efficiency of this kind of draft tube is less almost 60%

3. **Elbow with varying cross section**-It is similar to the Bent Draft tube except the bent part is of varying cross section with rectangular outlet.the horizontal portion of draft tube is generally inclined upwards to prevent entry of air from the exit end.

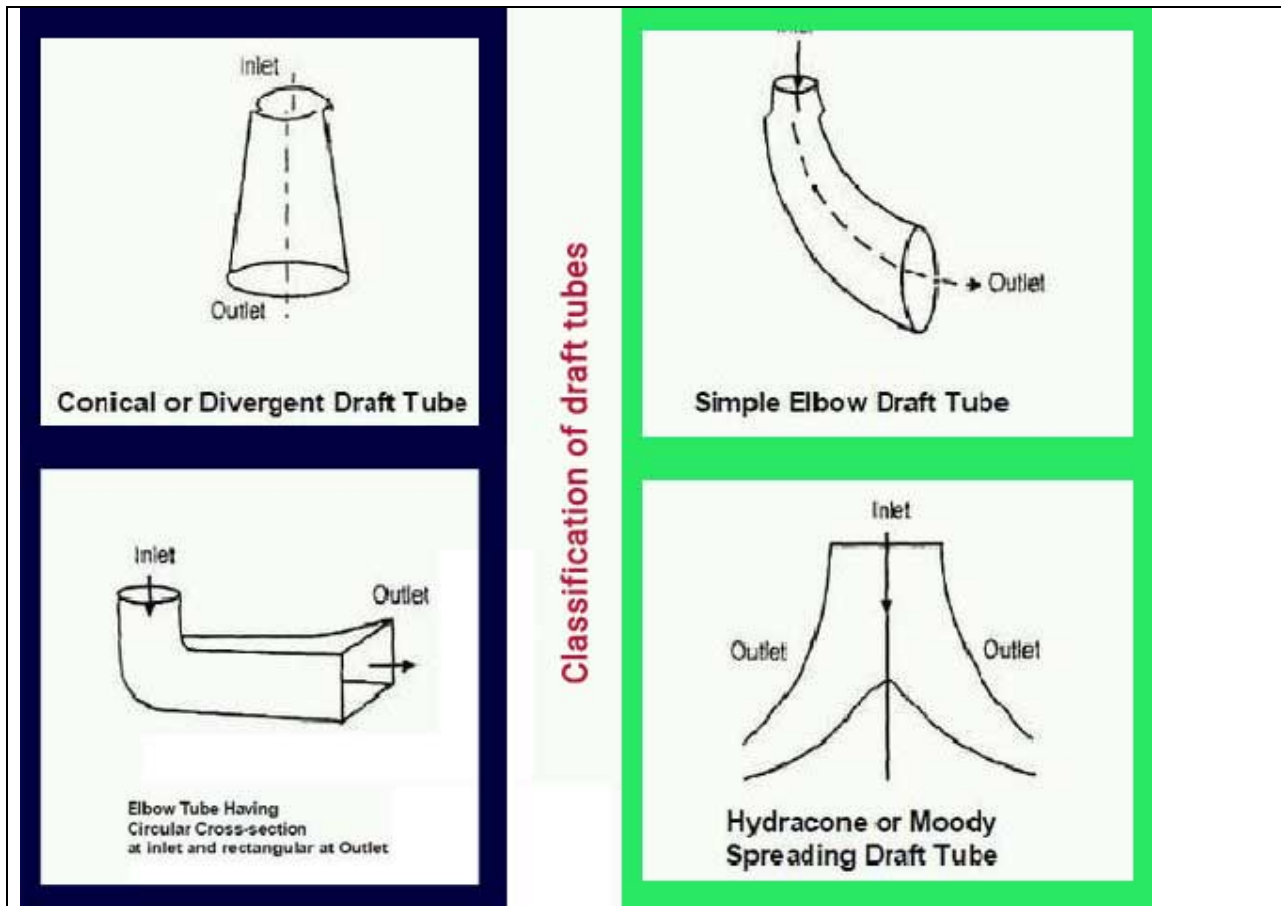

Specific speed of a turbine:

The specific speed of any turbine is the speed in rpm of a turbine geometrically similar to the actual turbine but of such a size that under corresponding conditions it will develop 1 metric horse power when working under unit head

Web link : https://nptel.ac.in/content/storage2/nptel_data3/html/mhrd/ict/text/112105206/lec13.pdf

Important Books/Journals for further learning including the page nos.:

Bansal, R.K., "Fluid Mechanics and Hydraulics Machines", (5th edition), Laxmi publications (P) Ltd, New Delhi, 2015. , Page No -915



LECTURE HANDOUTS

L-45

Robotics and Automation

II/III

Course Name with Code : 19RAC02 Fluid Mechanics and Machinery

Course Faculty : Dr. T.Yuvaraj

Unit : V

Topic of Lecture: Governing of Turbines

Introduction : (Maximum 5 sentences)

- Governing system or governor is the main controller of the hydraulic turbine.
- The governor varies the water flow through the turbine to control its speed or power output. Generating units speed and system frequency may be adjusted by the governor.

Prerequisite knowledge for Complete understanding and learning of Topic:

- Basic Physics and Mathematics

Detailed content of the Lecture:

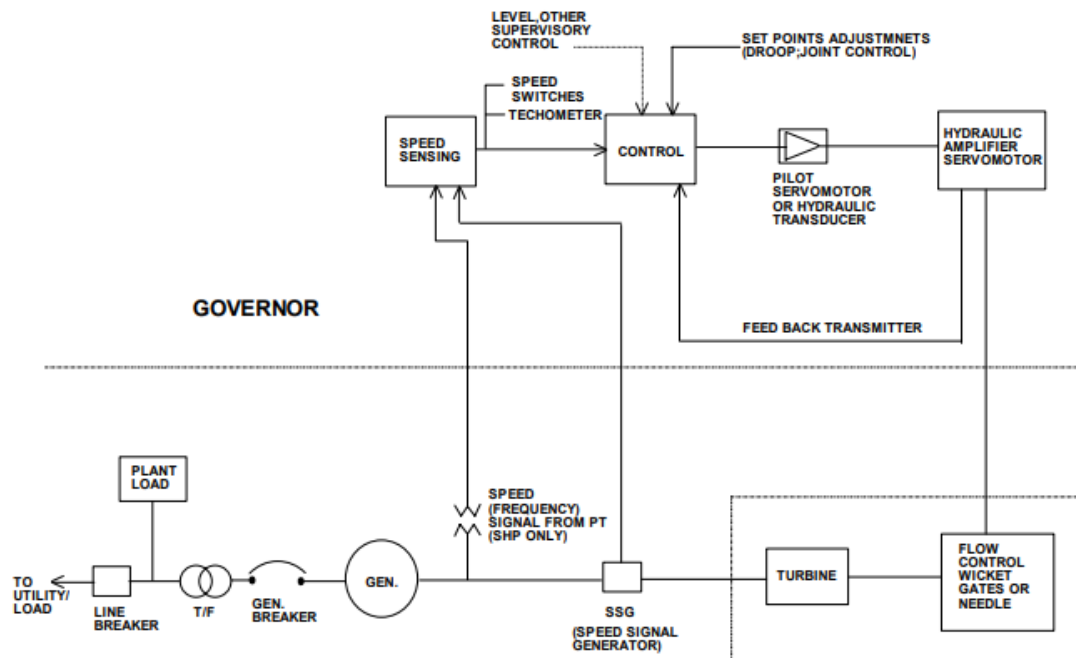

Governing system includes following.

- a) Speed sensing elements
- b) Governor control actuators
- c) Hydraulic pressure supply system
- d) Turbine control servomotors-these are normally supplied as part of turbine

The primary functions of the hydraulic turbine governor are as follows:

- i) To start, maintain and adjust unit speed for synchronizing with the running units/grid.
- ii) To maintain system frequency after synchronization by adjusting turbine output to load changes.
- iii) To share load changes with the other units in a planned manner in response to system frequency error.
- iv) To adjust output of the unit in response to operator or other supervisory commands.
- v) To perform normal shut down or emergency over speed shut down for protection.

In isolated systems the governor controls frequency. In large system it may be needed for load operation control for the system.

Web link :

https://www.iitr.ac.in/departments/HRE/uploads/modern_hydroelectric_engg/vol_1/Chapter-6_Hydro-Turbine_Governing_System.pdf

Important Books/Journals for further learning including the page nos.:

Bansal, R.K., "Fluid Mechanics and Hydraulics Machines", (5th edition), Laxmi publications (P) Ltd, New Delhi, 2015. , Page No -937