



MUTHAYAMMAL ENGINEERING COLLEGE

(An Autonomous Institution)

(Approved by AICTE, New Delhi, Accredited by NAAC & Affiliated to Anna University)

Rasipuram - 637 408, Namakkal Dist., Tamil Nadu



LECTURE HANDOUTS

L

MECH

II/IV

Course Name with Code : Applied Hydraulics and Pneumatics

Course Faculty : Dr S.Suresh

Unit : I

Topic of Lecture: General types of fluids -Fluid power symbols

Introduction : (Maximum 5 sentences)

- The fluid is categorized based on their general properties and behavior
- The fluid power symbols are required to design the hydraulic circuits

Prerequisite knowledge for Complete understanding and learning of Topic:
(Max. Four important topics)

- Basics of fluid mechanics

Detailed content of the Lecture:

General types of fluids

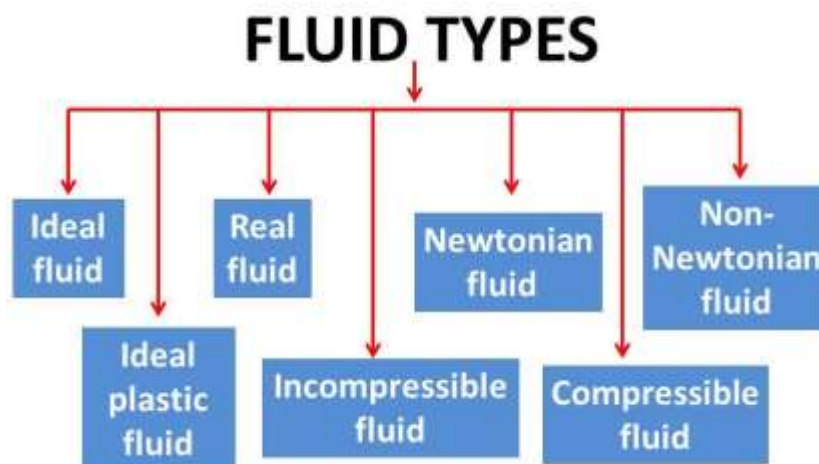



- (i) Water
- (ii) Water glycols
- (iii) Water oil emulsions
- (iv) Mineral oils
- (v) Phosphate esters

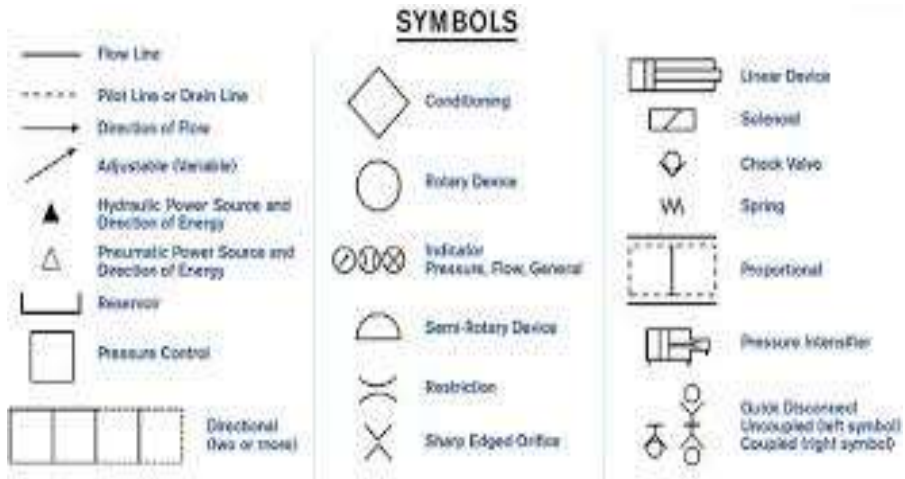

Fluid power symbols





Lines

-  -continuous line - flow line
-  -dashed line - pilot, drain
-  -envelope - long and short dashes around two or more component symbols.

Circular

-  -large circle - pump, motor
-  -small circle - Measuring devices
-  -semi-circle - rotary actuator



Square

-  -one square - pressure control function
-  -two or three adjacent squares - directional control

Diamond

-  -diamond - Fluid conditioner (filter, separator, lubricator, heat exchanger)

Miscellaneous Symbols

-  -Spring
-  -Flow Restriction

Triangle

-  -solid - Direction of Hydraulic Fluid Flow

Video Content / Details of website for further learning (if any):

https://nptel.ac.in/content/storage2/nptel_data3/html/mhrd/ict/text/112105047/lec41.pdf

Important Books/Journals for further learning including the page nos.:

Hydraulic and Pneumatic Controls-II Edition, R.Srinivasan, Vijay Nicole Imprints Private Limited, pp: 6-7



MUTHAYAMMAL ENGINEERING COLLEGE

(An Autonomous Institution)

(Approved by AICTE, New Delhi, Accredited by NAAC & Affiliated to Anna University)

Rasipuram - 637 408, Namakkal Dist., Tamil Nadu



LECTURE HANDOUTS

L

MECH

II/IV

Course Name with Code : Applied Hydraulics and Pneumatics

Course Faculty : Dr S.Suresh

Unit : I

Topic of Lecture: Basics of Hydraulics-Applications of Pascals Law

Introduction : (Maximum 5 sentences)

Pascal's Law expresses the central concept of fluid power: "Pressure exerted by a confined fluid acts undiminished equally in all directions

Prerequisite knowledge for Complete understanding and learning of Topic:
(Max. Four important topics)

- Basic mathematics such as Calculation of pressure, force, area

Detailed content of the Lecture:

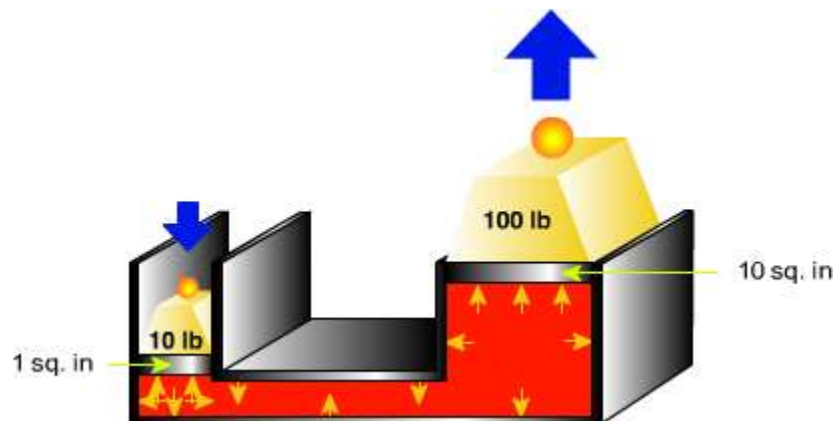

Pascal's Law states that a pressure acting on a confined fluid is transmitted equally and undiminished in all directions. In the figure below, a 10 pound force acting on a 1 square inch area generates a pressure of 10 pounds per square inch (psi) throughout the container acting equally on all surfaces

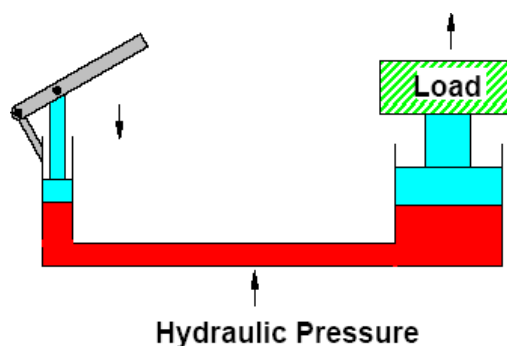

Conversion of Energy in Hydraulics

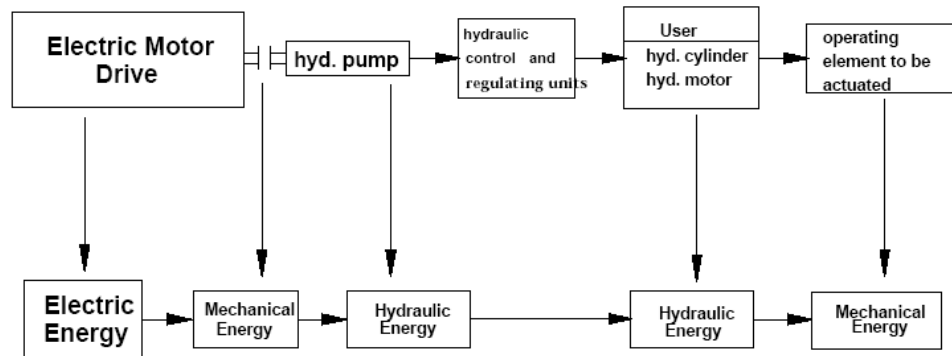

Video Content / Details of website for further learning (if any):

<https://www.youtube.com/watch?v=hV5IEooHqIw>

https://nptel.ac.in/content/storage2/nptel_data3/html/mhrd/ict/text/108105088/lec34.pdf

Important Books/Journals for further learning including the page nos.:

Hydraulic and Pneumatic Controls-II Edition, R.Srinivasan, Vijay Nicole Imprints Private Limited, pp: 2



MUTHAYAMMAL ENGINEERING COLLEGE

(An Autonomous Institution)

(Approved by AICTE, New Delhi, Accredited by NAAC & Affiliated to Anna University)

Rasipuram - 637 408, Namakkal Dist., Tamil Nadu



LECTURE HANDOUTS

L

MECH

II/IV

Course Name with Code : Applied Hydraulics and Pneumatics

Course Faculty : Dr S.Suresh

Unit : I

Topic of Lecture: Reynold's number

Introduction : (Maximum 5 sentences)

- The Reynolds Number is a non dimensional parameter

Prerequisite knowledge for Complete understanding and learning of Topic:
(Max. Four important topics)

- Basic mathematics and fluid properties

Detailed content of the Lecture:

- The Reynolds number is the ratio of inertial forces to viscous forces and is a convenient parameter for predicting if a flow condition will be laminar or turbulent.
- It can be interpreted that when the viscous forces are dominant (slow flow, low Re) they are sufficient enough to keep all the fluid particles in line, then the flow is laminar.
- When the inertial forces dominate over the viscous forces (when the fluid is flowing faster and Re is larger) then the flow is turbulent
- The Reynolds Number is a non dimensional parameter defined by the ratio of dynamic pressure (ρu^2) and shearing stress ($\mu u / L$) and can be expressed as

$$\text{Re} = (\rho u^2) / (\mu u / L)$$

$$= \rho u L / \mu$$

$$= u L / \nu \quad \text{where}$$

Re = Reynolds Number (non-dimensional)

$$\rho = \text{density (kg/m}^3\text{)}$$

u = velocity (m/s, ft/s)

μ = dynamic viscosity (Ns/m²)

L = characteristic length (m)

ν = kinematic viscosity (m²/s)

Video Content / Details of website for further learning (if any):

https://nptel.ac.in/content/storage2/nptel_data3/html/mhrd/ict/text/105101082/lec36.pdf

Important Books/Journals for further learning including the page nos.:

Hydraulic and Pneumatic Controls-II Edition, R.Srinivasan, Vijay Nicole Imprints Private Limited, pp: 24



MUTHAYAMMAL ENGINEERING COLLEGE

(An Autonomous Institution)

(Approved by AICTE, New Delhi, Accredited by NAAC & Affiliated to Anna University)

Rasipuram - 637 408, Namakkal Dist., Tamil Nadu



LECTURE HANDOUTS

L

MECH

II/IV

Course Name with Code : Applied Hydraulics and Pneumatics

Course Faculty : Dr S.Suresh

Unit : I

Topic of Lecture: Darcy's equation

Introduction : (Maximum 5 sentences)

- The frictional head loss can be calculated using a mathematical relationship that is known as Darcy's equation for head loss.

Prerequisite knowledge for Complete understanding and learning of Topic:

(Max. Four important topics)

- Basic mathematics and
- Basic fluid properties

Detailed content of the Lecture:

$$H_f = f L \frac{v^2}{D 2 g}$$

f = friction factor (unit less)

L = length of pipe (m)

D = diameter of pipe (m)

v = fluid velocity (m/sec)

g = gravitational acceleration (m/sec²)

Video Content / Details of website for further learning (if any):

https://nptel.ac.in/content/storage2/nptel_data3/html/mhrd/ict/text/105101082/lec36.pdf

Important Books/Journals for further learning including the page nos.:

Hydraulic and Pneumatic Controls-II Edition, R.Srinivasan, Vijay Nicole Imprints Private Limited, pp: 25



MUTHAYAMMAL ENGINEERING COLLEGE

(An Autonomous Institution)

(Approved by AICTE, New Delhi, Accredited by NAAC & Affiliated to Anna University)

Rasipuram - 637 408, Namakkal Dist., Tamil Nadu



LECTURE HANDOUTS

L

MECH

II/IV

Course Name with Code : Applied Hydraulics and Pneumatics

Course Faculty : Dr S.Suresh

Unit : I

Topic of Lecture: Losses in pipe, valves and fittings

Introduction : (Maximum 5 sentences)

- Whenever there is a flow through a pipe, there will always be a head loss.
- The head loss can be segregated into two main categories namely major loss and minor losses.

**Prerequisite knowledge for Complete understanding and learning of Topic:
(Max. Four important topics)**

Basic Mathematics and concept of flow through pipes

Detailed content of the Lecture:

- In addition to losses due to [friction in a pipeline system](#), there are also losses associated with flow through valves and fittings. These losses are called minor losses, but these losses must be considered if the piping system has a lot of such fittings. These losses are treated as equivalent frictional losses.
- The minor loss may be treated either as a pressure drop $\Delta p = -K\rho V^2/2$ or as a head loss $\Delta h = -KV^2/(2g)$.
- The value of the loss coefficient 'K' is obtained through experimental data. Generally for valves and fittings, manufacturers provide loss coefficient 'K' value.
- It may also be calculated from the equivalent length concept: $K = fL_e/D$

Video Content / Details of website for further learning (if any):

https://nptel.ac.in/content/storage2/nptel_data3/html/mhrd/ict/text/105101082/lec36.pdf

Important Books/Journals for further learning including the page nos.:

Hydraulic and Pneumatic Controls-II Edition, R.Srinivasan, Vijay Nicole Imprints Private Limited, pp: 26



MUTHAYAMMAL ENGINEERING COLLEGE

(An Autonomous Institution)

(Approved by AICTE, New Delhi, Accredited by NAAC & Affiliated to Anna University)

Rasipuram - 637 408, Namakkal Dist., Tamil Nadu



LECTURE HANDOUTS

L

MECH

II/IV

Course Name with Code : Applied Hydraulics and Pneumatics

Course Faculty : Dr S.Suresh

Unit : I

Topic of Lecture: Introduction to fluid power

Introduction : (Maximum 5 sentences)

- Fluid power technology is a means to convert, transmit, control and apply fluid energy to perform useful work.
- Fluid power includes hydraulics and pneumatics.

Prerequisite knowledge for Complete understanding and learning of Topic:

Fluid mechanics, Fluid machineries

Detailed content of the Lecture:

- Fluid power is energy transmitted and controlled by means of a pressurized fluid, either liquid or gas.
- The term fluid power applies to both hydraulics and pneumatics.
- Hydraulics uses pressurized liquid, for example, oil or water;
- Pneumatics uses compressed air or other neutral gases.
- Fluid power can be effectively combined with other technologies through the use of sensors, transducers and microprocessors.

Web link : <https://nptel.ac.in/courses/112/106/112106175/>

Important Books/Journals for further learning including the page nos.:

Hydraulic and Pneumatic Controls-II Edition, R.Srinivasan, Vijay Nicole Imprints Private Limited, pp: 1-2



MUTHAYAMMAL ENGINEERING COLLEGE

(An Autonomous Institution)

(Approved by AICTE, New Delhi, Accredited by NAAC & Affiliated to Anna University)

Rasipuram - 637 408, Namakkal Dist., Tamil Nadu



LECTURE HANDOUTS

L

MECH

II/IV

Course Name with Code : Applied Hydraulics and Pneumatics

Course Faculty : Dr S.Suresh

Unit : I

Topic of Lecture: Advantages of fluid power, Application of fluid power system

Introduction : (Maximum 5 sentences)

- Fluid Power has a lot of advantages which can be used for effective functioning of automation'
- Fluid power is used in various sectors such as transports, industries etc.

Prerequisite knowledge for Complete understanding and learning of Topic:

Fluid mechanics, Automobile Engineering

Detailed content of the Lecture:

The advantages of fluid power

- Multiplication and variation of force-
- Easy, accurate control-
- Multi-function control-
- High horsepower, low weight ratio
- Low speed torque-
- Constant force or torque
- Safety in hazardous environments
- Established standards and engineering

Fluid power applications

Mobility

- Here fluid power is used to transport, excavate and lift materials as well as control or power mobile equipment.
- End use industries include construction, agriculture, marine and the military.
- Applications include backhoes, graders, tractors, truck brakes
- And suspensions, spreaders and highway maintenance vehicles.

Industrial:

- Here fluid power is used to provide power transmission and motion control for the machines of industry.
- End use industries range from plastics working to paper production.
- Applications include metalworking equipment, controllers, automated manipulators, material handling and assembly equipment.

Aerospace:

- Fluid power is used for both commercial and military aircraft, spacecraft and related support equipment. Applications include landing gear, brakes, flight controls, motor controls and cargo loading equipment

Video Content / Details of website for further learning (if any):

<https://nptel.ac.in/courses/112/106/112106175/>

Important Books/Journals for further learning including the page nos.:

Hydraulic and Pneumatic Controls-II Edition, R.Srinivasan, Vijay Nicole Imprints Private Limited, pp: 3-5



MUTHAYAMMAL ENGINEERING COLLEGE

(An Autonomous Institution)

(Approved by AICTE, New Delhi, Accredited by NAAC & Affiliated to Anna University)

Rasipuram - 637 408, Namakkal Dist., Tamil Nadu



LECTURE HANDOUTS

L

MECH

II/IV

Course Name with Code : Applied Hydraulics and Pneumatics

Course Faculty : Dr S.Suresh

Unit : I

Topic of Lecture: Types of fluid power systems, Properties of hydraulic fluids

Introduction : (Maximum 5 sentences)

- Fluid power system is broadly categorized based on the type of control system used and based on the type of control used
- The physical and chemical properties of the hydraulic fluids play an important role in being used in fluid power systems

**Prerequisite knowledge for Complete understanding and learning of Topic:
(Max. Four important topics)**

Fluid Mechanics, Basics of fluids

Detailed content of the Lecture:

Types of fluid power systems

1. Based on the control system

- a) Open-loop system: There is no feedback in the open system and performance is based on the characteristics of the individual components of the system.
- b) Closed-loop system: This system uses feedback. The output of the system is fed back to a comparator by a measuring element. The comparator compares the actual output to the desired output and gives an error signal to the control element. The error is used to change the actual output and bring it closer to the desired value.

. 2. Based on the type of control

- a) Fluid logic control: This type of system is controlled by hydraulic oil or air. The system employs fluid logic devices such as AND, NAND, OR, NOR, etc.
Two types of fluid logic systems are available:
 - (i) Moving part logic (MPL): These devices are miniature fluid elements using moving parts such as diaphragms, disks and poppets to implement various logic gates.
 - (ii) Fluidics: Fluid devices contain no moving parts and depend solely on interacting fluid jets to implement various logic gates.
- b) Electrical control:
- c) Electronic control

Properties of hydraulic fluids

- Specific gravity
- Viscosity

- Stability in shear
- Foaming characteristics
- Cloud point and pour point
- Oil compressibility and bulk modulus
- Coefficient of thermal expansion
- Wettability
- Flammability
- Chemical stability
- Affinity to moisture
- Gumming tendency
- Oxidation tendency
- Corrosion resistance
- Wear resistance
- Compatibility with system material
- Heat dissipation property
- Nontoxic, easy to handle and availability

Video Content / Details of website for further learning (if any):

<https://nptel.ac.in/content/storage2/courses/112106175/downloads/Module%201/FAQ/FAQ-Lecture%203.pdf>

Important Books/Journals for further learning including the page nos.:

Hydraulic and Pneumatic Controls-II Edition, R.Srinivasan, Vijay Nicole Imprints Private Limited, pp: 6-7



MUTHAYAMMAL ENGINEERING COLLEGE

(An Autonomous Institution)

(Approved by AICTE, New Delhi, Accredited by NAAC & Affiliated to Anna University)
Rasipuram - 637 408, Namakkal Dist., Tamil Nadu



LECTURE HANDOUTS

L

MECH

II/IV

Course Name with Code : Applied Hydraulics and Pneumatics

Course Faculty : Dr S.Suresh

Unit : I

Topic of Lecture: Laminar and Turbulent flow

Introduction : (Maximum 5 sentences)

1. Flow is classified according to the travel pattern of the fluid particles

Prerequisite knowledge for Complete understanding and learning of Topic:

(Max. Four important topics)

Basics of Fluid Mechanics

Detailed content of the Lecture:

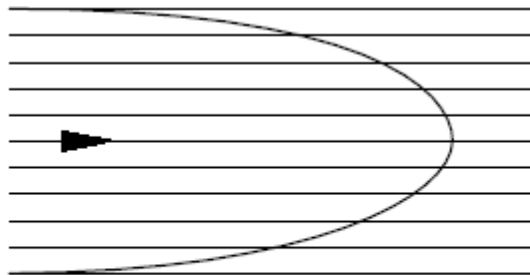

LAMINAR FLOW

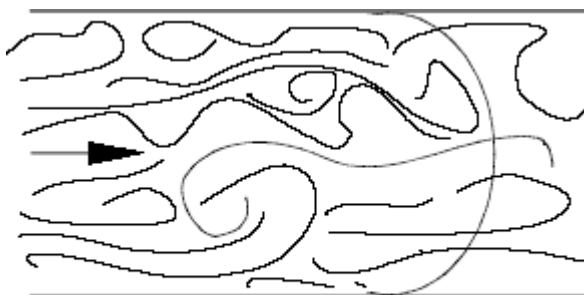

TURBULENT FLOW

Video Content / Details of website for further learning (if any):

https://nptel.ac.in/content/storage2/nptel_data3/html/mhrd/ict/text/105101082/lec36.pdf

Important Books/Journals for further learning including the page nos.:

Hydraulic and Pneumatic Controls-II Edition, R.Srinivasan, Vijay Nicole Imprints Private Limited, pp: 23



MUTHAYAMMAL ENGINEERING COLLEGE

(An Autonomous Institution)

(Approved by AICTE, New Delhi, Accredited by NAAC & Affiliated to Anna University)

Rasipuram - 637 408, Namakkal Dist., Tamil Nadu



LECTURE HANDOUTS

L - 2

Mech

II/IV

Course Name with Code : 16MED10/Hydraulics and Pneumatics

Course Faculty : Dr S.Suresh

Unit : II

Topic of Lecture: Pump classification-Gear Pump-Construction and working

Introduction :

- A pump is a device that moves fluids (liquids or gases), by mechanical action.
- Pumps operate by some mechanism (typically [reciprocating](#) or [rotary](#)) and consume [energy](#) to perform [mechanical work](#) moving the fluid.
- Pumps operate via many energy sources, including manual operation, [electricity](#), [engines](#), or [wind power](#), come in many sizes, from microscopic for use in medical applications to large industrial pumps

Prerequisite knowledge for Complete understanding and learning of Topic:
(Max. Four important topics)

- Basics of fluid, mechanical, and electrical systems.

Detailed content of the Lecture:

Classification of pumps

1. Gear pumps

- External gear pumps
- Internal gear pumps
- Lobe pumps
- Screw pumps

2. Vane pumps

- Unbalanced vane pumps
- Balanced vane pumps

3. Piston pumps

- Axial design
- Radial design

1. Gear pumps

a) External gear pumps

- A gear pump is a type of positive displacement (PD) pump. Gear pumps use the actions of rotating cogs or gears to transfer fluids.
- An external gear pump consists of two identical, interlocking gears supported by separate shafts. Generally, one gear is driven by a motor and this drives the other gear (the idler)

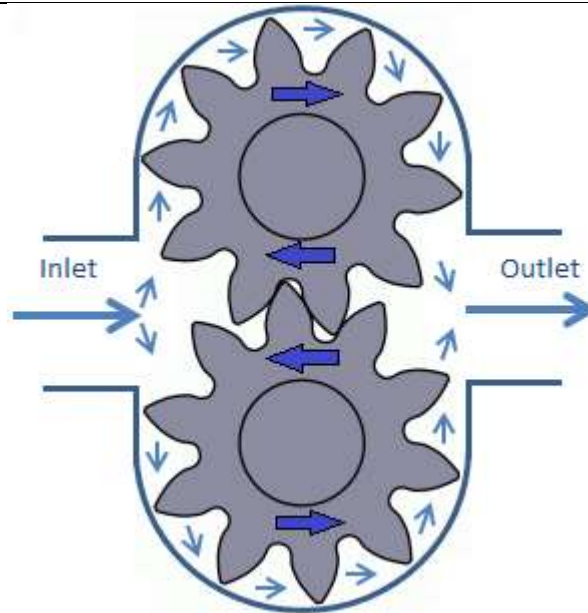

Internal gear pumps

- A gear pump is a type of positive displacement (PD) pump. Gear pumps use the actions of rotating cogs or gears to transfer fluids.
- An internal gear pump operates on the same principle but the two interlocking gears are of different sizes with one rotating inside the other.

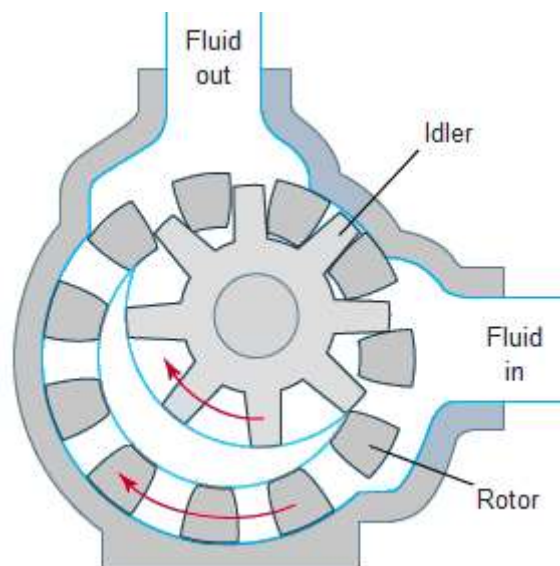

Application

- Transfer, lubrication, processing and hydraulic..

c) Lobe pump

- Lobe pumps are similar to external gear pumps in operation in that fluid flows around the interior of the casing.
- As the lobes come out of mesh, they create expanding volume on the inlet side of the pump. Liquid flows into the cavity and is trapped by the lobes as they rotate.

Lobe Pump

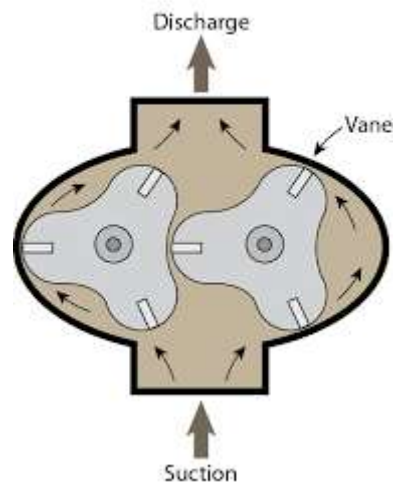

d) Screw pumps

- A screw pump is a type of positive displacement pump that uses two or more screws that intermesh to pressurize fluids and move them in a system.
- The screws take in fluid then push it out from the other side while increasing its pressure.

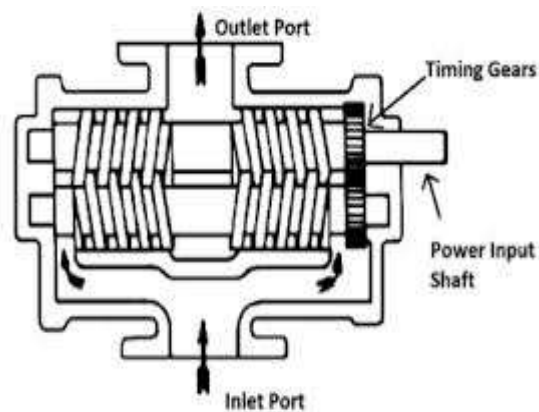

Video Content / Details of website for further learning (if any):

External Gear Pump Working Animation With Detail Explanation | TS7STUDYZONE
<https://www.youtube.com/watch?v=cMmwb3JmL00>

Important Books/Journals for further learning including the page nos.: 38,39,40&41

Reference Book

Hydraulic and Pneumatic Controls-II Edition, R.Srinivasan, Vijay Nicole Imprints Private Limited, 2006



LECTURE HANDOUTS

L - 3

Mech

II/IV

Course Name with Code : Applied Hydraulics and Pneumatics

Course Faculty : Dr S.Suresh

Unit : II

Topic of Lecture: Vane and Piston Pump- Construction and working

Introduction :

- Vane pumps have a rotor that spins inside a large circular or oval chamber called a cam ring.
- Vane chambers increase in volume on the inlet side where they take in fluid, and decrease in volume on the discharge side which forces the fluid out of the pump.
- A piston pump is a type of positive displacement pump where the high-pressure seal reciprocates with the piston.
- Piston pumps can be used to move liquids or compress gases. They can operate over a wide range of pressures.

Prerequisite knowledge for Complete understanding and learning of Topic:
(Max. Four important topics)

- Basics of fluid, mechanical, and electrical systems.

Detailed content of the Lecture:

1. Vane pumps

- a) Balanced Vane pump
- b) Unbalanced vane pump

Balanced Vane pump : Fixed displacement

- Pumping chambers are formed between succeeding vanes, carrying oil from the inlet to the outlet.
- A partial vacuum is created at the inlet as the space between vanes increases. The oil is squeezed out at the outlet as the pumping chamber's size decreases.

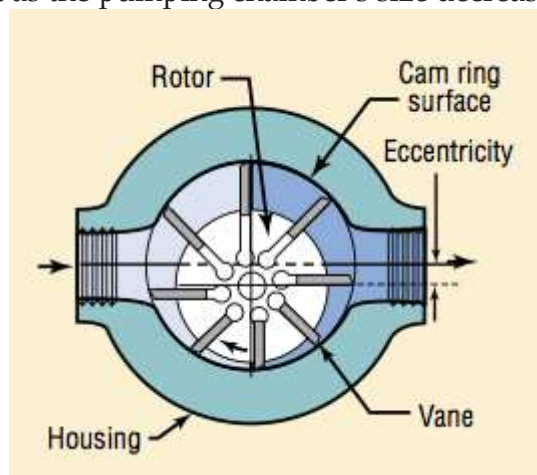

Unbalanced vane pump : Fixed or Variable displacement/ Pressure compensated

- A cam ring's shape is a true circle that is on a different centerline from a rotor's.
- Pump displacement depends on how far a rotor and ring are eccentric.
- The advantage of a true-circle ring is that control can be applied to vary the eccentricity and thus vary the displacement.
- A disadvantage is that an unbalanced pressure at the outlet is effective against a small area of the rotor's edge, imposing side loads on the shaft.

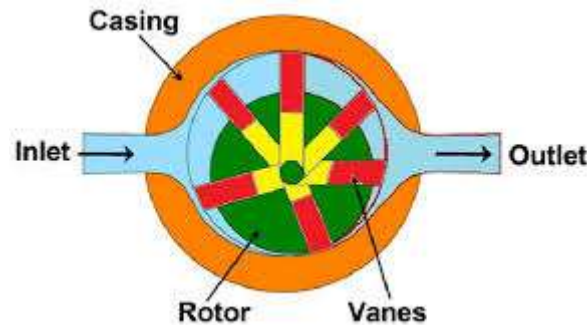

Piston pump

- A piston pump is a type of positive displacement pump where the high-pressure seal reciprocates with the piston.
- Piston pumps can be used to move liquids or compress gases. They can operate over a wide range of pressures.
- High pressure operation can be achieved without a strong effect on flow rate.

There are two types

1. Axial Piston pumps

- a) Bent axis type
- b) Swash plate type

2. Radial Piston pumps

a) Bent axis type

- In this pump, the pistons are at an angle to the drive shaft and Thrust Plate.
- The piston block shaft is connected to the drive shaft by a universal joint, the drive shaft, thrust plate, piston block shaft, and piston block all revolve.

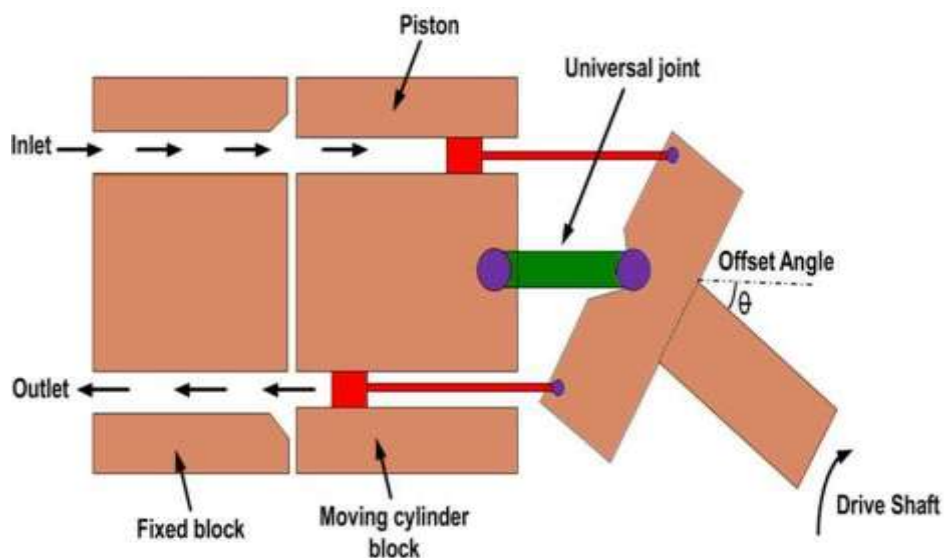

b) Swash plate type

- These pumps are commonly used in steering gear system. Swash plate pumps have a rotating cylinder containing pistons.
- A spring pushes the pistons against a stationary swash plate, which sits at an angle to the cylinder.

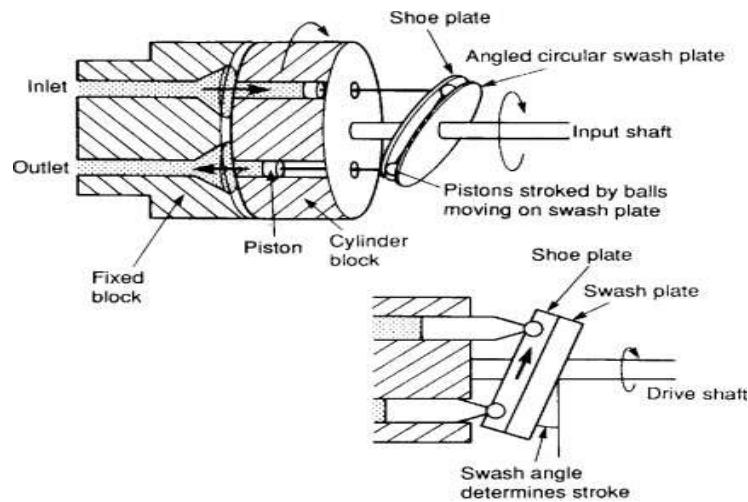

2.Radial piston pump

- A radial piston pump is a type of hydraulic piston pump.
- The rotor, mounted eccentrically in the pump housing, forces the pistons in and out of cylinders as it rotates, which cause hydraulic fluid to be sucked into the cylinder cavity and then be discharged from it.

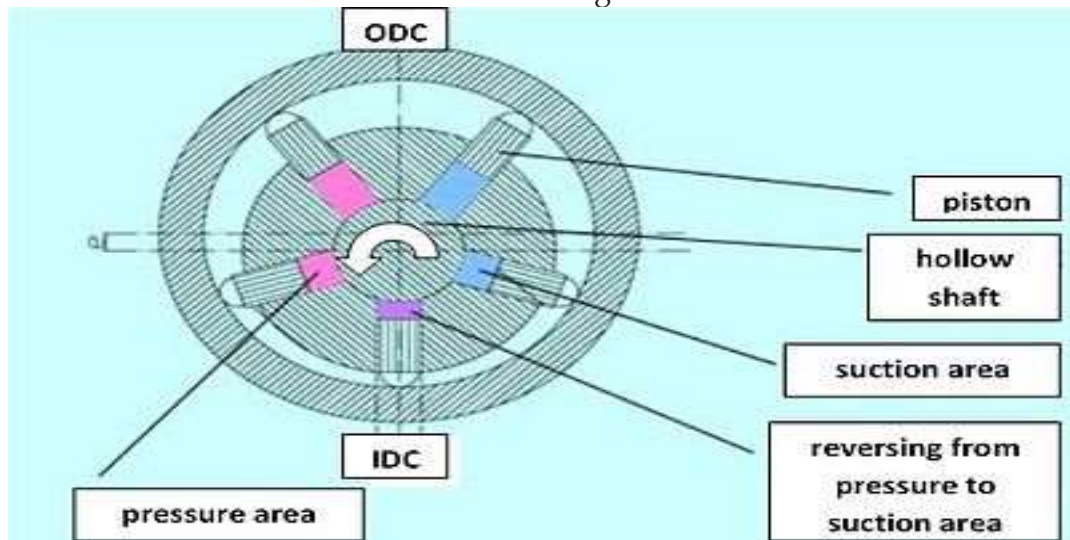

Video Content / Details of website for further learning (if any):

Balanced and unbalanced vane pump

<https://www.lunchboxsessions.com/materials/fixed-variable-displacement-pumps/introduction-to-vane-pumps-lesson>

Important Books/Journals for further learning including the page nos.: 57

Reference Book

Hydraulic and Pneumatic Controls-II Edition, R.Srinivasan, Vijay Nicole Imprints Private Limited, 2006



MUTHAYAMMAL ENGINEERING COLLEGE

(An Autonomous Institution)

(Approved by AICTE, New Delhi, Accredited by NAAC & Affiliated to Anna University)

Rasipuram - 637 408, Namakkal Dist., Tamil Nadu



LECTURE HANDOUTS

L - 4

Mech

II/IV

Course Name with Code : Applied Hydraulics and Pneumatics

Course Faculty : Dr S.Suresh

Unit : II

Topic of Lecture: Pump performance- Variable displacement pumps

Introduction :

- Pump is a machine or mechanical equipment which is required to lift liquid from low level to high level or to flow liquid from low pressure area to high pressure area or as a booster in a piping network system.
- A variable displacement pump is a device that converts mechanical energy to hydraulic (fluid) energy. The displacement, or amount of fluid pumped per revolution of the pump's input shaft can be varied while the pump is running.

Prerequisite knowledge for Complete understanding and learning of Topic: (Max. Four important topics)

- Basics of fluid, mechanical, and electrical systems.

Detailed content of the Lecture:

- Pump manufacturers run tests to determine performance data for their various types of pumps
- The overall efficiency of a pump can be computed by comparing the power available at the out put of the pump to the power supplied at the input.
- Overall efficiency can be classified in to two distinct components called volumetric and mechanical efficiencies.

1. Volumetric Efficiency

- It indicates the amount of leakage within the pump. These Involves considerations such as manufacturing tolerances and flexing of the pump casing under the design pressure operating conditions.

$$\eta_v = \frac{\text{Actual flow rate produced by pump}}{\text{Theoretical flow rate the pump should produce}} \\ = Q_A / Q_T \times 100$$

2. Mechanical Efficiency

- It indicates the amount of energy losses that occurs due to reasons other than leakages. This includes friction in bearings and between other mating parts.

$$\eta_m = \frac{\text{Theoretical power required to operate the pump}}{\text{Actual power delivered by the pump}}$$

$$= (P \times Q_T) / (2\pi NT/60) \times 100$$

3. Overall efficiency

It considers all the losses

$$\eta_o = \text{Power output by pump (Hydraulic power)} / \text{Actual power delivered by the pump}$$

$$= \eta_v \times \eta_m$$

Video Content / Details of website for further learning (if any):

Important Books/Journals for further learning including the page nos.: 59,60

Reference Book

Hydraulic and Pneumatic Controls-II Edition, R.Srinivasan, Vijay Nicole Imprints Private Limited, 2006



MUTHAYAMMAL ENGINEERING COLLEGE

(An Autonomous Institution)

(Approved by AICTE, New Delhi, Accredited by NAAC & Affiliated to Anna University)

Rasipuram - 637 408, Namakkal Dist., Tamil Nadu



LECTURE HANDOUTS

L - 5

Mech

II/IV

Course Name with Code : Applied Hydraulics and Pneumatics

Course Faculty : Dr S.Suresh

Unit : II

Topic of Lecture: Fluid power Actuators: Linear and Types

Introduction :

- Fluid power actuators receive fluid from a pump (typically driven by an electric motor). After the fluid has been pressure, flow, and directionally controlled, the actuator converts its energy into rotary or linear motion to do useful work.
- An actuator is a kind of motor used to move or control a mechanism. It can use many power sources, including electric current or pressure from a hydraulic or pneumatic component. Its goal is to convert that energy into the motion the system requires to do its work.
- A linear actuator is a device that develops a force and a motion through a straight line. A stepper motor-based linear actuator uses a stepping motor as the source of rotary power. Inside the rotor there's a threaded precision nut instead of a shaft; the shaft is replaced by a precision lead screw.

Prerequisite knowledge for Complete understanding and learning of Topic: (Max. Four important topics)

- Basics of fluid, mechanical, and electrical systems.

Detailed content of the Lecture:

- Hydraulic actuators use liquid pressure rather than instrument air pressure to apply force on the diaphragm to move the valve actuator and then to position valve stem.
- Nearly all hydraulic actuator designs use a piston rather than a diaphragm to convert fluid pressure into mechanical force.
- The high pressure rating of piston actuators lends itself well to typical hydraulic system pressures, and the lubricating nature of hydraulic oil helps to overcome the characteristic friction of piston-type actuators.
- A linear actuator is an actuator that creates motion in a straight line, in contrast to the circular motion of a conventional electric motor.
- Linear actuators are used in machine tools and industrial machinery, in computer peripherals such as disk drives and printers, in valves and dampers, and in many other places where linear motion is required.

Semi-Rotary Actuators

- A rotary actuator is an actuator that produces a rotary motion or torque. The simplest actuator is purely mechanical, where linear motion in one direction gives rise to rotation.
- Cylinder based semi-rotary actuators typically use two single-acting pistons to generate a

linear movement and a gear to transform the piston displacement into a rotation.

Vane type Actuators

- A vane actuator consists of a vane mounted on a central shaft enclosed in a cylindrical chamber.
- The vane rotates upon pressurization and continues to rotate until it reaches the end of the stroke.
- Air pressure applied to the other side of the vane causes it to rotate the shaft in the opposite direction.

Vane Type Motor:

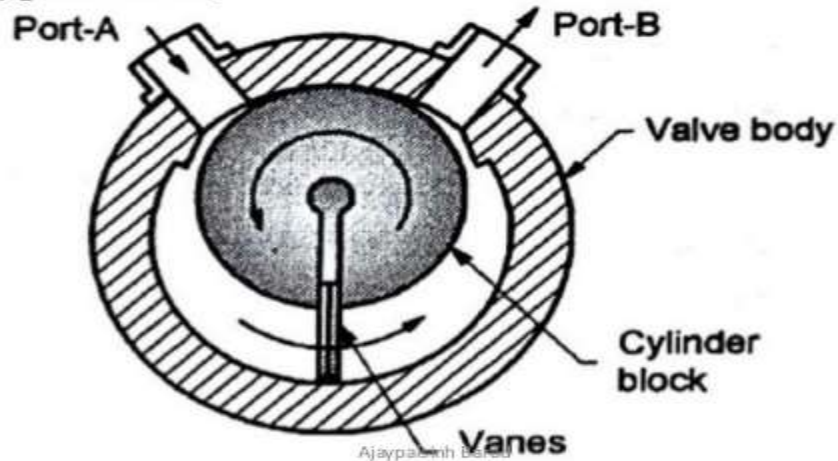

Piston type Semi - Rotary Actuator

Rack and pinion Semi- Rotary Actuator

- A rack and pinion is a type of linear actuator that comprises a circular gear (the pinion) engaging a linear gear (the rack), which operate to translate rotational motion into linear motion.
- Driving the pinion into rotation causes the rack to be driven linearly.
- Driving the rack linearly will cause the pinion to be driven into a rotation.

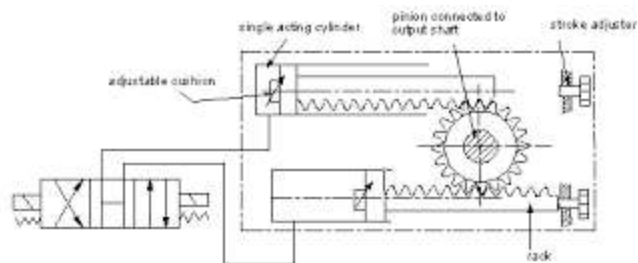

Lever arm semi rotary Actuator

- Double acting cylinder can be made to generate rotary motion by using a lever arm .
- The angle of rotation will be less than 180 degree.

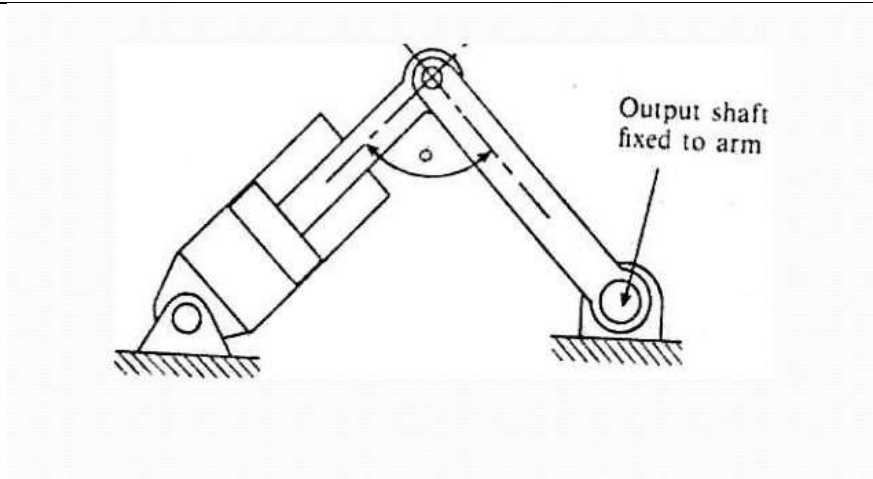

Chain and sprocket semi - rotary Actuator

- A chain and sprocket drive is a type of power transmission in which a roller chain engages with two or more toothed wheels or sprockets, used in engines as a drive from crankshaft to camshaft.
- A chain and sprocket drive is one way of conveying power to the wheels of a vehicle.
- A mechanical actuator is chain block hoisting weight in which mechanical motion of chain over the sprocket is utilized to lift a rated load.
- In this type, compressed air at high pressure is used which converts this energy into either linear or rotary motion

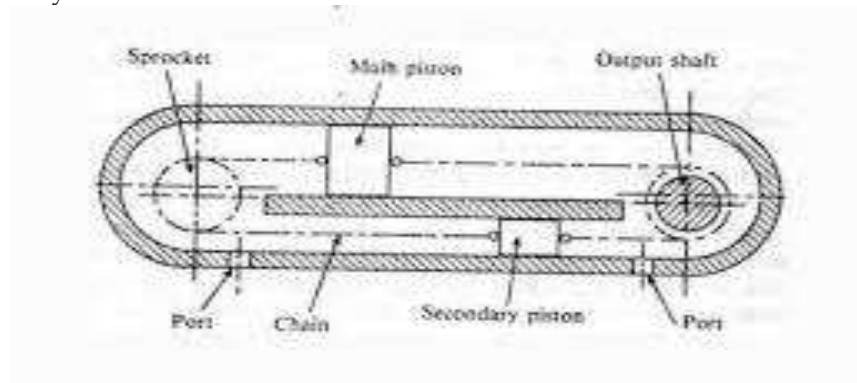

Video Content / Details of website for further learning (if any):

SEMI-ROTARY CYLINDER / PNEUMATIC / DOUBLE-ACTING / POSITION-SENSING

<https://www.directindustry.com/prod/festo/product-4735-1718205.html>

Important Books/Journals for further learning including the page nos.: 61,62

Reference Book

Hydraulic and Pneumatic Controls-II Edition, R.Srinivasan, Vijay Nicole Imprints Private Limited, 2006



LECTURE HANDOUTS

L - 6

Mech

II/IV

Course Name with Code : Applied Hydraulics and Pneumatics

Course Faculty : Dr S.Suresh

Unit : II

Topic of Lecture: Single acting and double acting like tandem cylinders

Introduction :

- A single acting cylinder is one where the thrust or output force is developed in only one direction. The piston is returned by a fitted spring, or by some other external means such as a weight, mechanical movement, gravity or an external spring
- A double-acting hydraulic cylinder has a port at each end, supplied with hydraulic fluid for both the retraction and extension of the piston

Prerequisite knowledge for Complete understanding and learning of Topic: (Max. Four important topics)

- Basics of fluid, mechanical, and electrical systems.

Detailed content of the Lecture:

Single acting Cylinder

- The piston is returned by a fitted spring, or by some other external means such as a weight, mechanical movement, gravity or an external spring.
- They have a single port to allow compressed air to enter the cylinder to move the piston to the desired position.

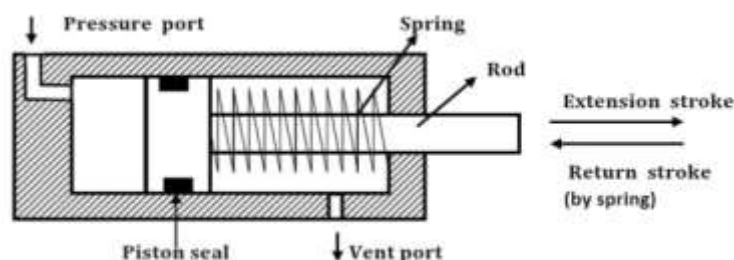

Double acting Cylinder

- A double acting pneumatic cylinder is one where the thrust, or output force, is developed in both extending and retracting directions.
- Double acting cylinders have a port at each end and move the piston forward and back by alternating the port that receives the high-pressure air, necessary when a load must be

moved in both directions such as opening and closing a gate.

- Air pressure is applied alternatively to the opposite ends of the piston

DOUBLE ACTING CYLINDER WITH A PISTON ROD ON BOTH SIDES

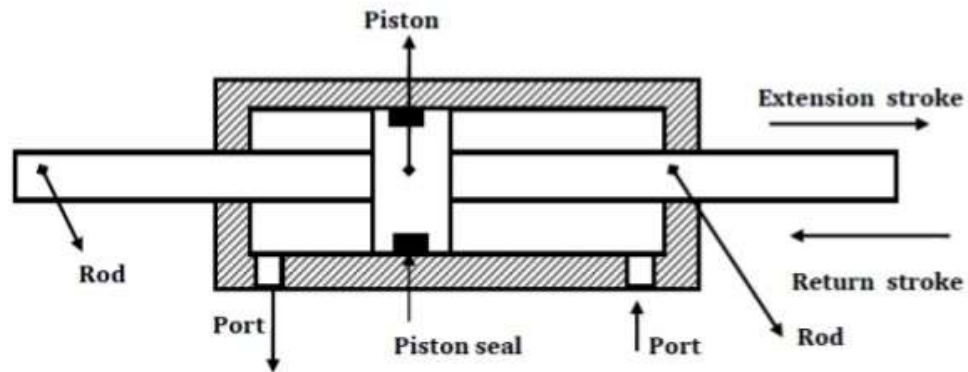

- Tandem cylinders use multiple pistons connected through a common rod to generate relatively high force from a low supply pressure and small bore.
- Tandem cylinder is a set up of Two (Mostly) Pistons , one behind the other with a common piston axis , and operated by a single push-rod.
- Tandem systems are a space efficient and mechanically safe way to set up braking for multiple wheels.

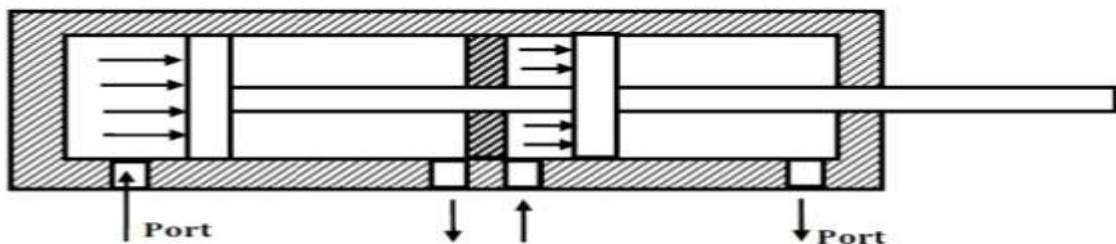

Video Content / Details of website for further learning (if any):

Master cylinder - How it works! (Animation)

<https://www.youtube.com/watch?v=Xk2zGvKfrhc>

Important Books/Journals for further learning including the page nos.: 64

Reference Book

Hydraulic and Pneumatic Controls-II Edition, R.Srinivasan, Vijay Nicole Imprints Private Limited ,2006



MUTHAYAMMAL ENGINEERING COLLEGE

(An Autonomous Institution)

(Approved by AICTE, New Delhi, Accredited by NAAC & Affiliated to Anna University)

Rasipuram - 637 408, Namakkal Dist., Tamil Nadu



LECTURE HANDOUTS

L - 7

Mech

II/IV

Course Name with Code : Applied Hydraulics and Pneumatics

Course Faculty : Dr S.Suresh

Unit : II

Topic of Lecture: Rodless, Telescopic Cylinders

Introduction :

- Pneumatic cylinder slides or rodless cylinders are designed to provide power and linear motion while supporting a load. Standalone pneumatic cylinders are suitable for providing power and motion, but are not designed to provide support for a load.
- Many cylinders have no way of holding the position of the piston rod, due to the rod's ability to rotate.
- Pneumatic cylinder slides provide the load capability and a stable, non-rotating platform on which to mount tooling or other actuators

Prerequisite knowledge for Complete understanding and learning of Topic:

(Max. Four important topics)

- Basics of fluid, mechanical, and electrical systems.

Detailed content of the Lecture:

Rodless cylinder

- Rodless cylinders are linear devices that use pressurized fluid to move a load within power transfer operations.
- A rodless cylinder should be used if the footprint of the area is small, when the load needs to be moved some distance from the cylinder itself, and when the load must move within the length of the cylinder.
- Pneumatic cylinder slides or rodless cylinders are designed to provide power and linear motion while supporting a load.

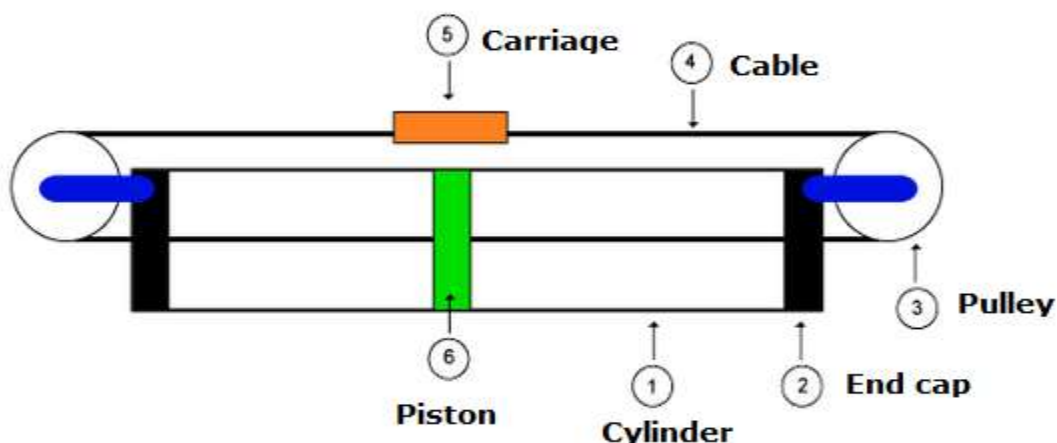

Telescopic cylinders

- Telescopic cylinders are a special design of a hydraulic cylinder or pneumatic cylinder as well as pulley system which provide an exceptionally long output travel from a very compact retracted length.
- Typically the collapsed length of a telescopic cylinder is 20 to 40% of the fully extended length depending on the number of stages.
- Some pneumatic telescoping units are manufactured with retracted lengths of under 15% of overall extended unit length.

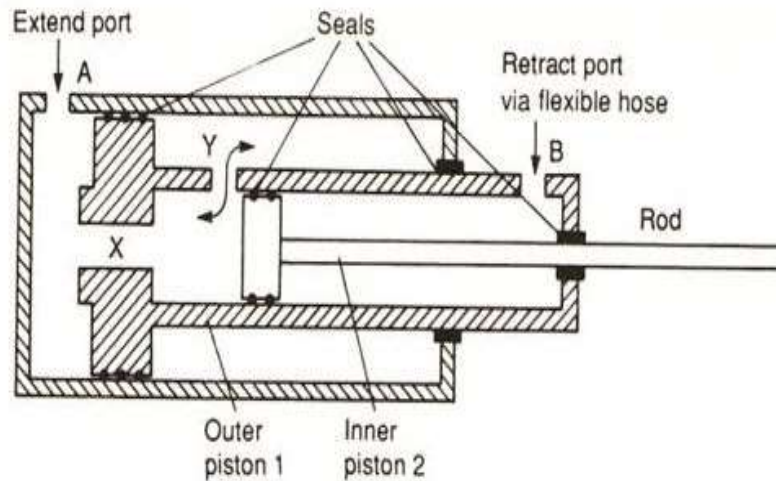

Video Content / Details of website for further learning (if any):

Hydraulic telescopic cylinder 2

<https://www.youtube.com/watch?v=ibDgkui-E-U>

Important Books/Journals for further learning including the page nos.: 69

Reference Book

Hydraulic and Pneumatic Controls-II Edition, R.Srinivasan, Vijay Nicole Imprints Private Limited, 2006



MUTHAYAMMAL ENGINEERING COLLEGE

(An Autonomous Institution)

(Approved by AICTE, New Delhi, Accredited by NAAC & Affiliated to Anna University)

Rasipuram - 637 408, Namakkal Dist., Tamil Nadu



LECTURE HANDOUTS

L - 8

Mech

II/IV

Course Name with Code : Applied Hydraulics and Pneumatics

Course Faculty : Dr S.Suresh

Unit : II

Topic of Lecture: Cushioning mechanism

Introduction :

- A hydraulic assembly includes a barrel having a head port disposed proximate an end of the barrel, a piston assembly disposed within the barrel and movable relative thereto, the piston assembly including a bore terminating at a back wall, the bore defining a longitudinal axis, and a plunger at least partially received within the bore and translatable along the longitudinal axis.
- The plunger includes a main body having an end facing the head port, a shoulder extending radially-outwardly from the main body, and a passageway extending through the main body.
- A spring is disposed in a first region defined between the shoulder and the back wall, the spring configured to exert a biasing force on the shoulder.

**Prerequisite knowledge for Complete understanding and learning of Topic:
(Max. Four important topics)**

- Basics of fluid, mechanical, and electrical systems.

Detailed content of the Lecture:

- Cushioning of some sort normally is required to decelerate a cylinder's piston before it strikes the end cap.
- Reducing the piston velocity as it approaches the end cap lowers the stresses on cylinder components and reduces vibration transmitted to the machine structure.
- When cylinders reach the end of their stroke, the pressure rises quickly, creating a shock wave in the hydraulic circuit.
- The pneumatic cushions decelerate the piston and rod assembly at the end of the cylinders travel, reducing internal impact force/noise and enabling faster piston velocities.

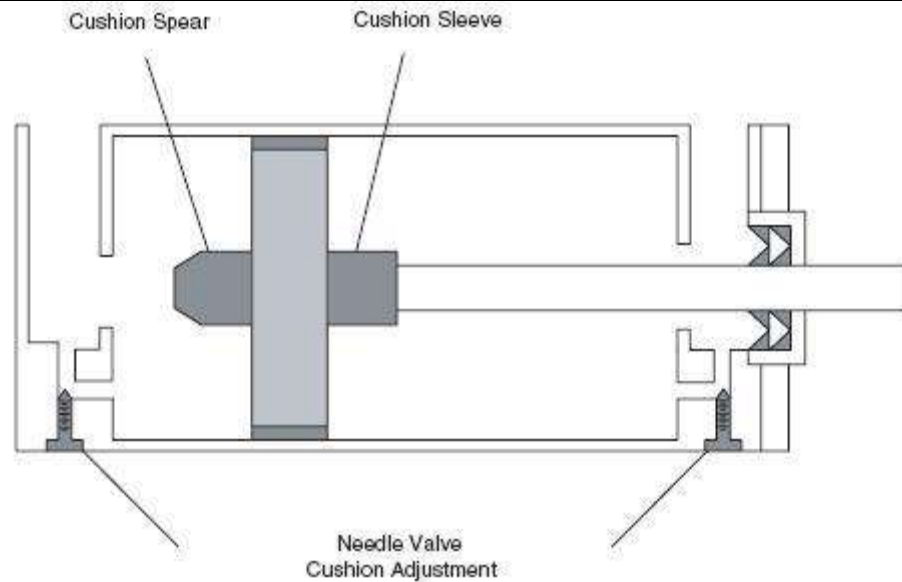

Video Content / Details of website for further learning (if any):

The Cushion Adjusting Screw That Will Rock Your World

<https://www.youtube.com/watch?v=x0O6Zq-PV0M>

Important Books/Journals for further learning including the page nos.: 65

Reference Book

Hydraulic and Pneumatic Controls-II Edition, R.Srinivasan, Vijay Nicole Imprints Private Limited ,2006



LECTURE HANDOUTS

L - 9

Mech

II/IV

Course Name with Code : Applied Hydraulics and Pneumatics

Course Faculty : Dr S.Suresh

Unit : II

Topic of Lecture: Construction of double acting cylinder-Rotary actuators

Introduction :

- Double-acting hydraulic cylinder has a port at each end, supplied with hydraulic fluid for both the retraction and extension of the piston.
- A double-acting cylinder is used where an external force is not available to retract the piston or it can be used where high force is required in both directions of travel.

Prerequisite knowledge for Complete understanding and learning of Topic: (Max. Four important topics)

- Basics of fluid, mechanical, and electrical systems.

Detailed content of the Lecture:

Double-acting cylinder

- Double-acting cylinder is a cylinder in which the working fluid acts alternately on both sides of the piston.
- In order to connect the piston in a double-acting cylinder to an external mechanism, such as a crank shaft, a hole must be provided in one end of the cylinder for the piston rod, and this is fitted with a gland or "stuffing box" to prevent escape of the working fluid.
- Double-acting cylinders are common in steam engines but unusual in other engine.
- Many hydraulic and pneumatic cylinders use them where it is needed to produce a force in both directions.

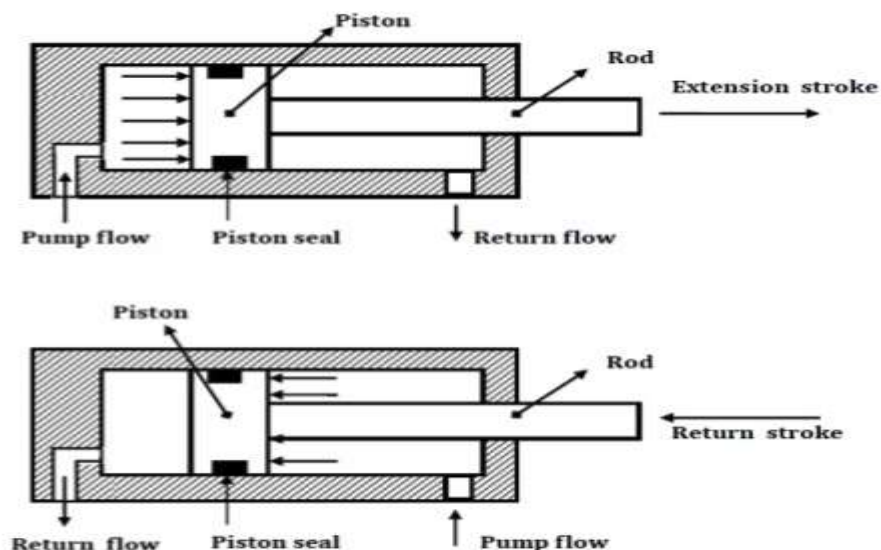

Rotary Actuator

- A rotary actuator is an actuator that produces a rotary motion or torque.
- The simplest actuator is purely mechanical, where linear motion in one direction gives rise to rotation.
- The most common actuators are electrically powered; others may be powered pneumatically or hydraulically, or use energy stored in springs.

Continuous Rotation Actuators :

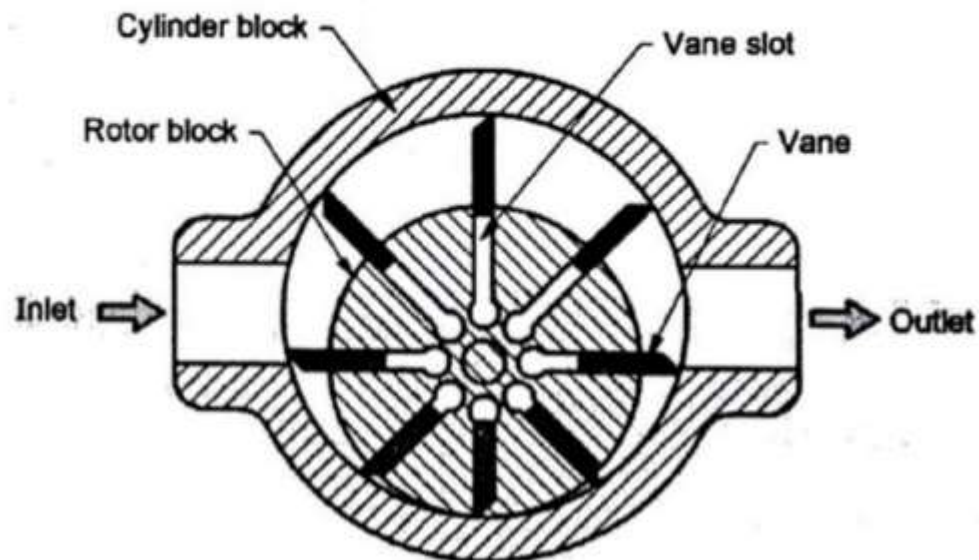

Video Content / Details of website for further learning (if any):

Animation : Single and Double-acting Cylinders in a Fluid System

<https://www.youtube.com/watch?v=CIOXkkVDiY>

Important Books/Journals for further learning including the page nos.: 34,30

Reference Book

Hydraulic and Pneumatic Controls-II Edition, R.Srinivasan, Vijay Nicole Imprints Private Limited ,2006



MUTHAYAMMAL ENGINEERING COLLEGE

(An Autonomous Institution)

(Approved by AICTE, New Delhi, Accredited by NAAC & Affiliated to Anna University)

Rasipuram - 637 408, Namakkal Dist., Tamil Nadu



LECTURE HANDOUTS

L - 10

Mech

II/IV

Course Name with Code : Applied Hydraulics and Pneumatics

Course Faculty : Dr S.Suresh

Unit : II

Topic of Lecture: Fluid Motors, Gear, Vane and Piston motors

Introduction :

- Hydraulic motors are rotary actuators that convert hydraulic, or fluid energy into mechanical power. They work in tandem with a hydraulic pump, which converts mechanical power into fluid, or hydraulic power.
- Hydraulic motors provide the force and supply the motion to move an external load.
- A hydraulic motor works the other way round as it converts hydraulic energy into mechanical energy a rotating shaft.
- It uses hydraulic pressure and flow to generate the required torque and rotation.

Prerequisite knowledge for Complete understanding and learning of Topic:
(Max. Four important topics)

- Basics of fluid, mechanical, and electrical systems.

Detailed content of the Lecture:

Fluid motor

- Hydraulic motors are rotary actuators that convert hydraulic or fluid energy into mechanical power.
- In the tandem with a hydraulic pump, which converts mechanical power into fluid, or hydraulic power.
- Torque, or the turning and twisting effort of the force of the motor.

Classification

1. Gear type hydraulic motor
2. Vane type hydraulic motor
3. Piston type hydraulic motor

1. Gear type hydraulic motor.

- Gear motors feature two gears, one being the driven gear – which is attached to the output shaft – and the idler gear.
- High-pressure oil is ported into one side of the gears, where it flows around the gears and housing, to the outlet port and compressed out of the motor.
- A gear motor (external gear) consists of two gears, the driven gear (attached to the output shaft by way of a key).

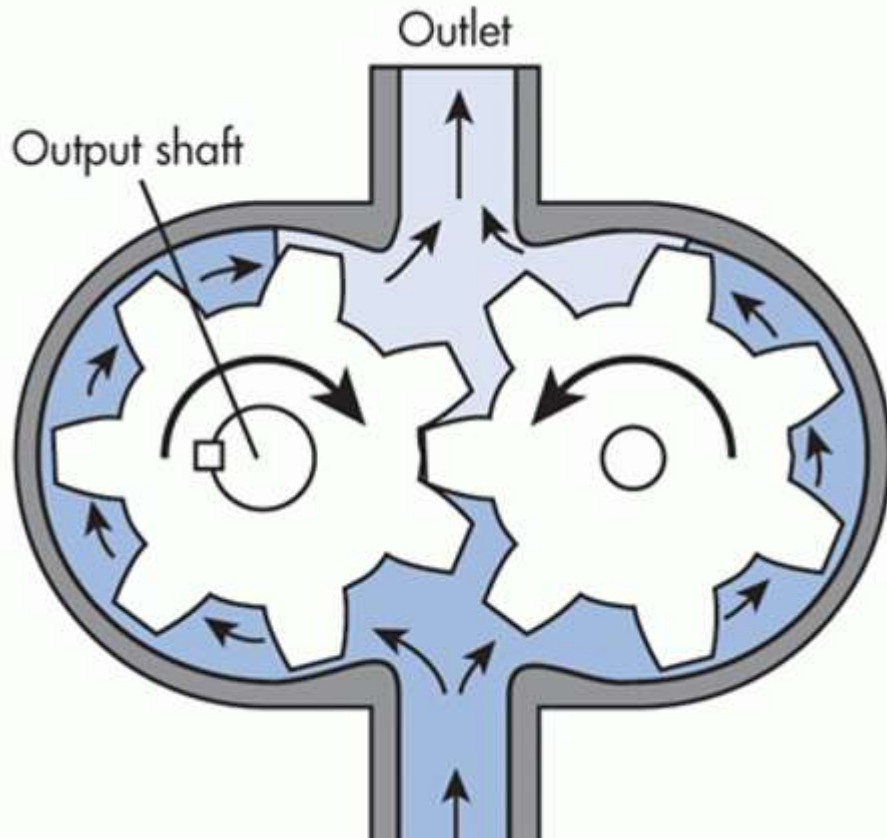

Vane type hydraulic motor

- A vane motor consists of a housing with an eccentric bore, in which runs a rotor with vanes in it that slide in and out.
- The force differential created by the unbalanced force of the pressurized fluid on the vanes causes the rotor to spin in one direction.

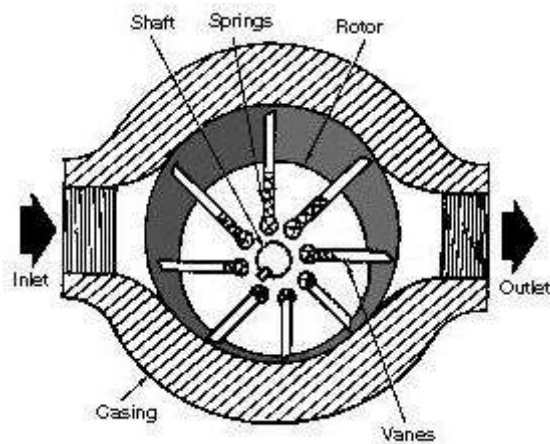

3. Piston type hydraulic motor

In-Line-Axis, Piston-Type Motors

- Piston type hydraulic motor are built-in, fixed- and variable-displacement models in several sizes. Torque is developed by a pressure drop through a motor.
- Pressure exerts a force on the ends of the pistons, which is translated into shaft rotation. Shaft rotation of most models can be reversed anytime by reversing the flow direction.

Bent-Axis, Piston-Type Motors.

- Variable-displacement motors can be controlled mechanically or by pressure compensation.

- A parallel component of thrust causes a flange to turn. Torque is maximum at maximum displacement; speed is at a minimum.
- This design piston motor is very heavy and bulky, particularly the variable- displacement motor.

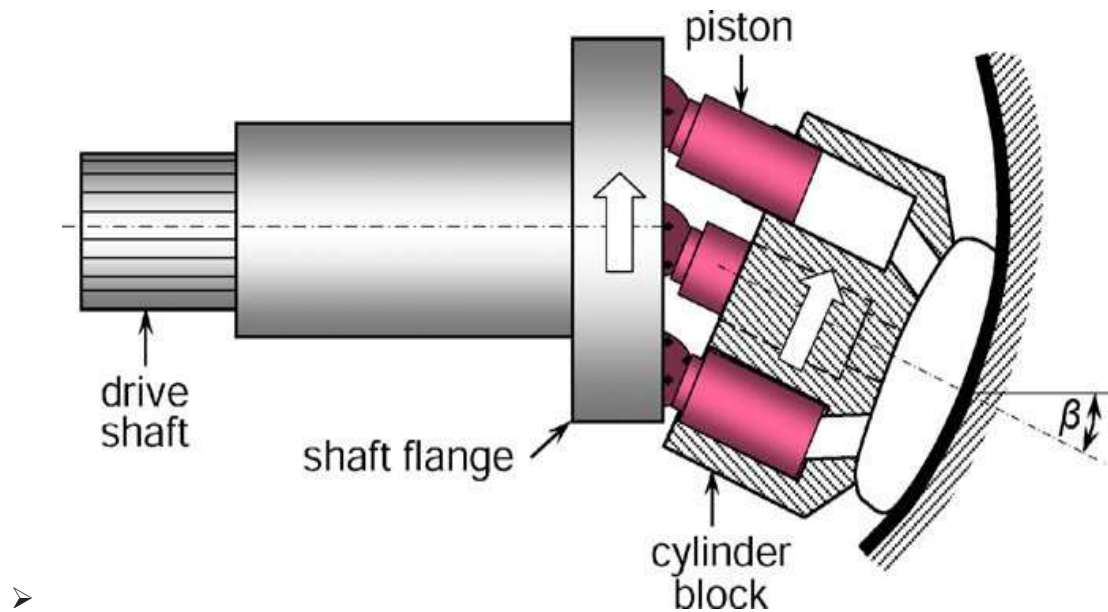

Video Content / Details of website for further learning (if any):

Bent-axis hydraulic motor animation and exploded view

<https://www.youtube.com/watch?v=ct8Au8T3arI>

Important Books/Journals for further learning including the page nos.: 30

Reference Book

Hydraulic and Pneumatic Controls-II Edition, R.Srinivasan, Vijay Nicole Imprints Private Limited ,2006



MUTHAYAMMAL ENGINEERING COLLEGE

(An Autonomous Institution)

(Approved by AICTE, New Delhi, Accredited by NAAC & Affiliated to Anna University)

Rasipuram - 637 408, Namakkal Dist., Tamil Nadu



LECTURE HANDOUTS

L -

Mech

II/IV

Course Name with Code : Applied Hydraulics and Pneumatics

Course Faculty : Dr S.Suresh

Unit : III

Topic of Lecture: Construction of control Components: DCV-3/2 way valve-4/2 way valve, shuttle valve

Introduction :

- Directional control valves (DCVs) are one of the most fundamental parts of hydraulic and pneumatic systems.
- DCVs allow fluid flow (hydraulic oil, water or air) into different paths from one or more sources.
- DCVs will usually consist of a spool inside a cylinder which is mechanically or electrically actuated. The position of the spool restricts or permits flow, thus it controls the fluid flow.

**Prerequisite knowledge for Complete understanding and learning of Topic:
(Max. Four important topics)**

- Basics of fluid, mechanical, and electrical systems.

Detailed content of the Lecture:

- Every system that transfers energy using pressurized incompressible hydraulic fluids is a hydraulic system.
- Transferring fluids directly through a pipeline won't create any hydraulic pressure. Instead, the system comprises of different hydraulic components like pump, actuators, valve, filter, reservoir, etc
- Controlling a single acting cylinder Operating a single acting cylinder is a typical application of 3/2-way valves.
- A single acting cylinder has one pneumatic port to fill and empty the air chamber. The cylinder moves in one direction by filling the air chamber, and returns by spring force.

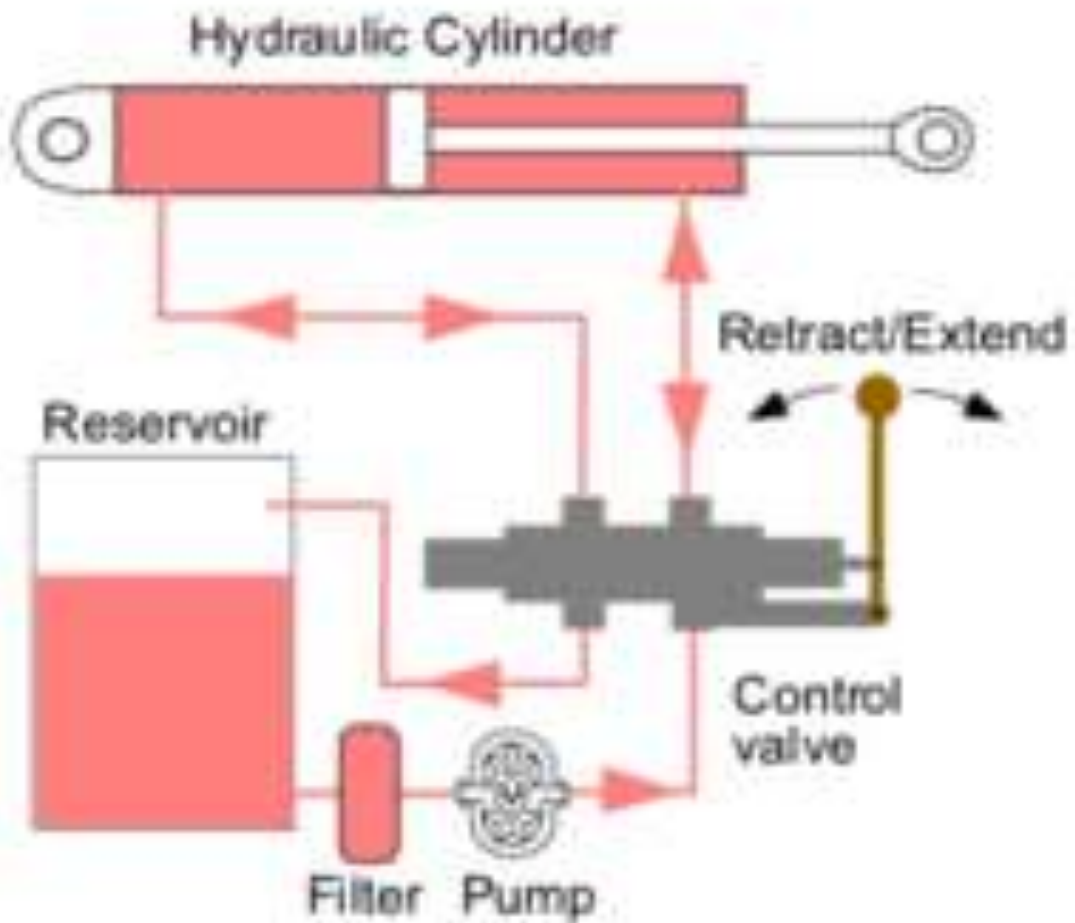

Direction control 3/2 way valve

- The valve uses the system pressure to move the spool. In order to do this an additional pilot valve is used.
- This pilot valve is a small direct operated 3/2-way valve.

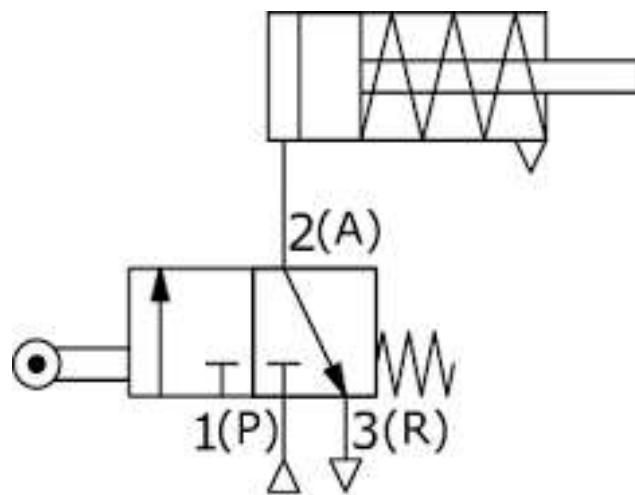

Single-acting cylinder drive

Direction control 4/2 way valve

- Four-way, directional-control valves are used to control the direction of fluid flow in a hydraulic circuit, which controls the direction of movement of a work cylinder or the rotation of a fluid motor.
- These valves are usually the sliding-spool type.

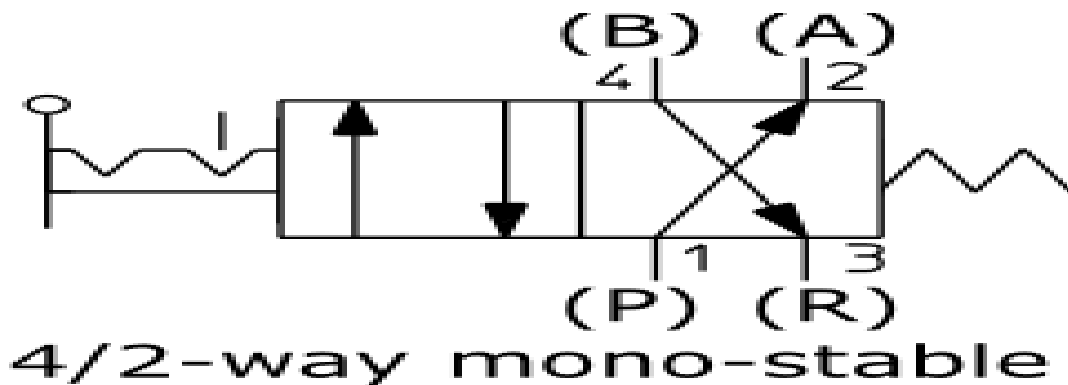

Shuttle valve

A shuttle valve is a type of valve which allows fluid to flow through it from one of two sources. Generally a shuttle valve is used in pneumatic systems, although sometimes it will be found in hydraulic systems.

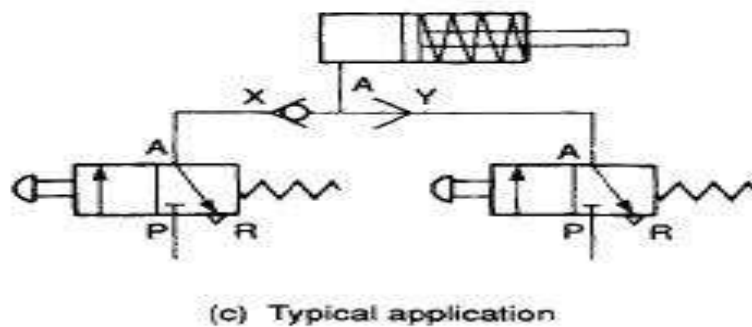
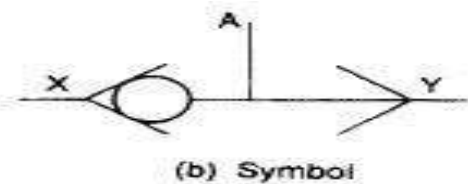
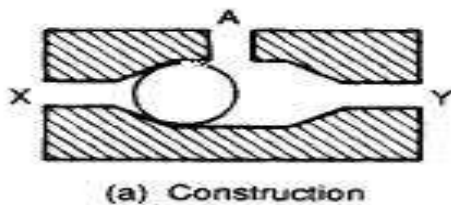

Video Content / Details of website for further learning (if any):

https://www.youtube.com/results?search_query=+DCV-3%2F2+way+valve

Important Books/Journals for further learning including the page nos.:90

Reference Book

Hydraulic and Pneumatic Controls-II Edition, R.Srinivasan, Vijay Nicole Imprints Private Limited,2006



MUTHAYAMMAL ENGINEERING COLLEGE

(An Autonomous Institution)

(Approved by AICTE, New Delhi, Accredited by NAAC & Affiliated to Anna University)

Rasipuram - 637 408, Namakkal Dist., Tamil Nadu



LECTURE HANDOUTS

L -

Mech

II/IV

Course Name with Code : Applied Hydraulics and Pneumatics

Course Faculty : Dr S.Suresh

Unit : III

Topic of Lecture: Check valve- pressure control valve

Introduction :

- Introduction to check valves. Check valves are generally installed in pipelines to prevent backflow.
- A check valve is basically a one-way valve, in which the flow can run freely one way, but if the flow turns the valve will close to protect the piping, other valves, pumps etc.
- Check valves are two-port valves, meaning they have two openings in the body, one for fluid to enter and the other for [fluid](#) to leave.
- There are various types of check valves used in a wide variety of applications. Check valves are often part of common household items. Although they are available in a wide range of sizes and costs, check valves generally are very small, simple, or inexpensive.
- Check valves work automatically and most are not controlled by a person or any external control; accordingly, most do not have any valve handle or stem.

Prerequisite knowledge for Complete understanding and learning of Topic: (Max. Four important topics)

- Basics of fluid, mechanical, and electrical systems.

Detailed content of the Lecture:

A check valve, clack valve, non-return valve, reflux valve, retention valve or one-way valve is a valve that normally allows fluid to flow through it in only one direction.

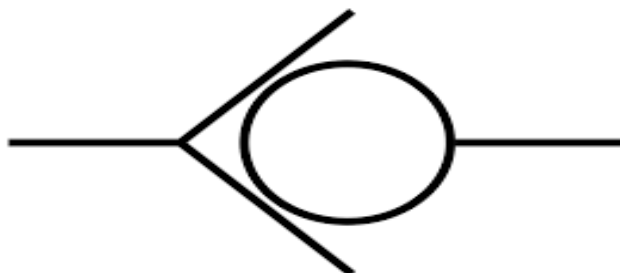

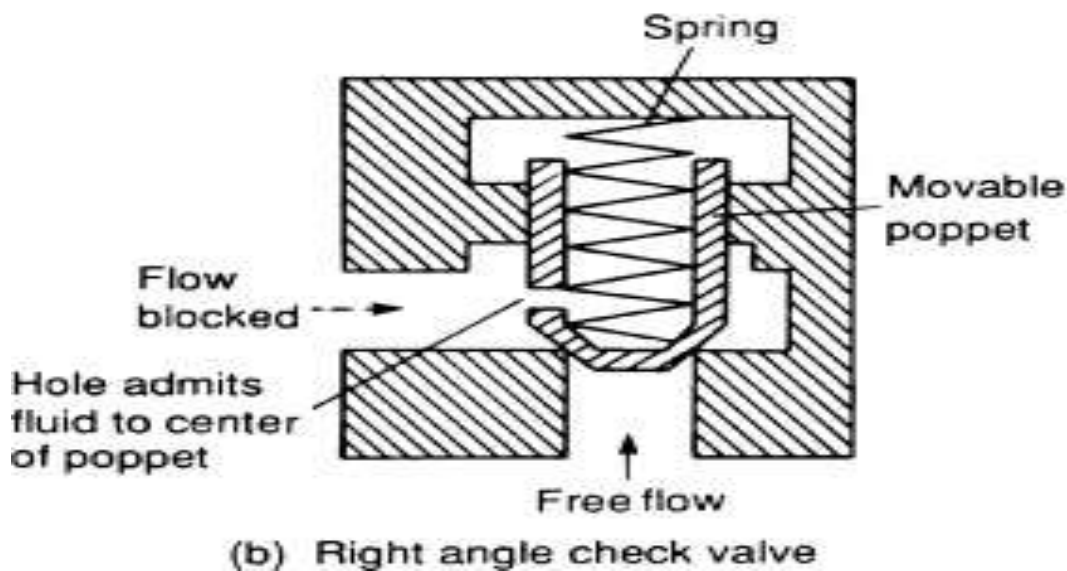
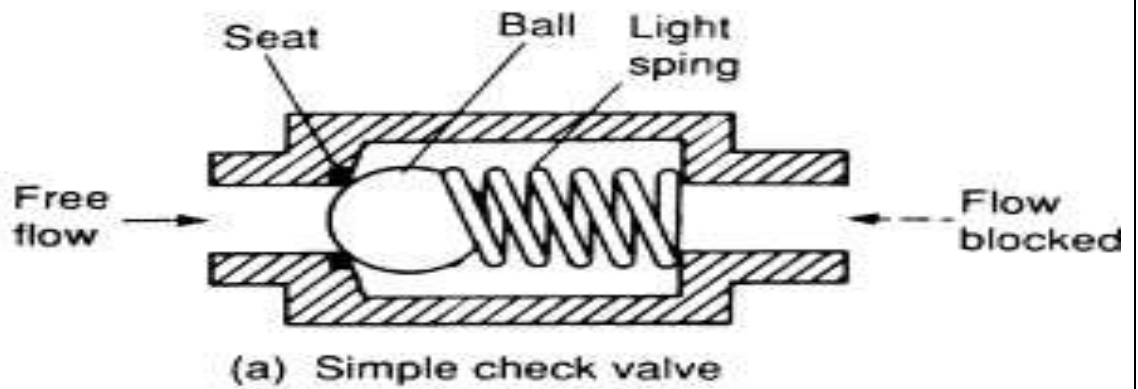

Pressure Control Valve

- Pressure valves are hydraulic valves that gradually (control) or suddenly (switch) change in position.
- The most common types of pressure control valves are the pressure relief valve and the pressure reducing valve. Pressure relief valves control the system pressure by relieving part, or all, of the flow to tank.
- Pressure-control valves are found in virtually every hydraulic system, and they assist in a variety of functions, from keeping system pressures safely below a desired upper limit to maintaining a set pressure in part of a circuit.
- A check valve, clack valve, non-return valve, reflux valve, retention valve or one-way valve is a valve that normally allows fluid (liquid or gas) to flow through it in only one direction.

Pressure control valves

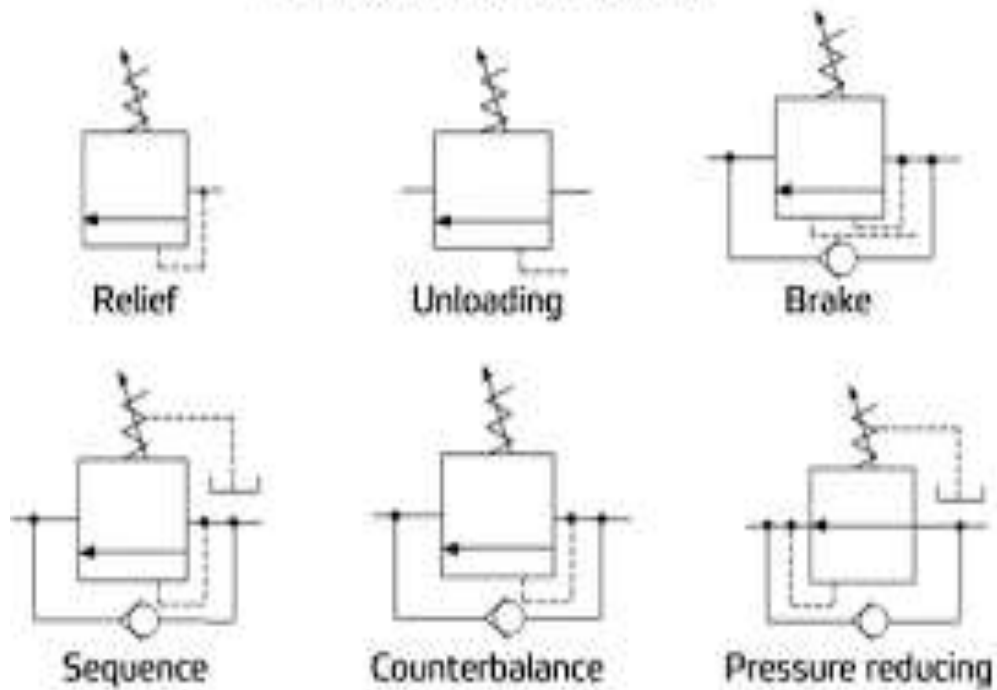

Video Content / Details of website for further learning (if any):

https://www.youtube.com/results?search_query=Check+valve-+pressure+control+valve

Important Books/Journals for further learning including the page nos.: 90

Reference Book

Hydraulic and Pneumatic Controls-II Edition, R.Srinivasan, Vijay Nicole Imprints Private Limited, 2006



MUTHAYAMMAL ENGINEERING COLLEGE

(An Autonomous Institution)

(Approved by AICTE, New Delhi, Accredited by NAAC & Affiliated to Anna University)

Rasipuram - 637 408, Namakkal Dist., Tamil Nadu



LECTURE HANDOUTS

L -

Mech

II/IV

Course Name with Code : Applied Hydraulics and Pneumatics

Course Faculty : Dr S.Suresh

Unit : III

Topic of Lecture: Pressure Reducing valve – Sequence valve

Introduction :

- The most practical components for maintaining secondary, lower pressure in a hydraulic system are pressure-reducing valves.
- Pressure-reducing valves are normally open, 2-way valves that close when subjected to sufficient downstream pressure.
- Pressure-reducing valve is normally an open, 2-way valve that allows system pressure fluid to flow through it until a set pressure is reached downstream.
- The forces exerted by pressure downstream actuate a pressure-reducing valve.
- These valves work by cutting down the amount of water which passes through a pipe. Water which is being forced through the pipes at high pressure before the valve will be slowed down after the valve.

Prerequisite knowledge for Complete understanding and learning of Topic: (Max. Four important topics)

- Basics of fluid, mechanical, and electrical systems.

Detailed content of the Lecture:

- Pressure reducing valve is a type of pressure control valve. This type of [valve](#) is used to maintain constant reduced pressure in a pipeline where the flow is fluctuating
2. Air compressor
 3. Aircraft and aerospace
 4. Ox fuel welding and cutting
 5. Used in inlet flow of load in pressure reactor
 6. Mining industries

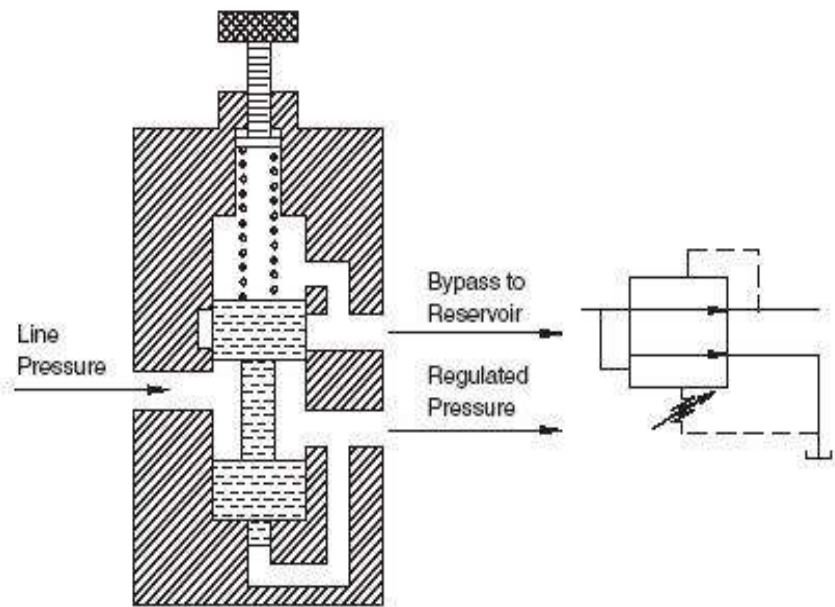

Schematic of pressure-reducing/relieving valve.

Sequence Valve

- The sequence valve is used to ensure that a certain pressure level is achieved in one branch of the circuit before a second branch is activated.
- The sequence valve is set on 600 psi, meaning that pressure must build to 600 psi before the valve opens.
- This setting ensures that the clamp cylinder exerts a 600-psi clamp force before the extend cylinder moves.
- When the directional control valve is shifted for reverse flow, the check valve provides free flow, and there is no sequencing of the cylinders

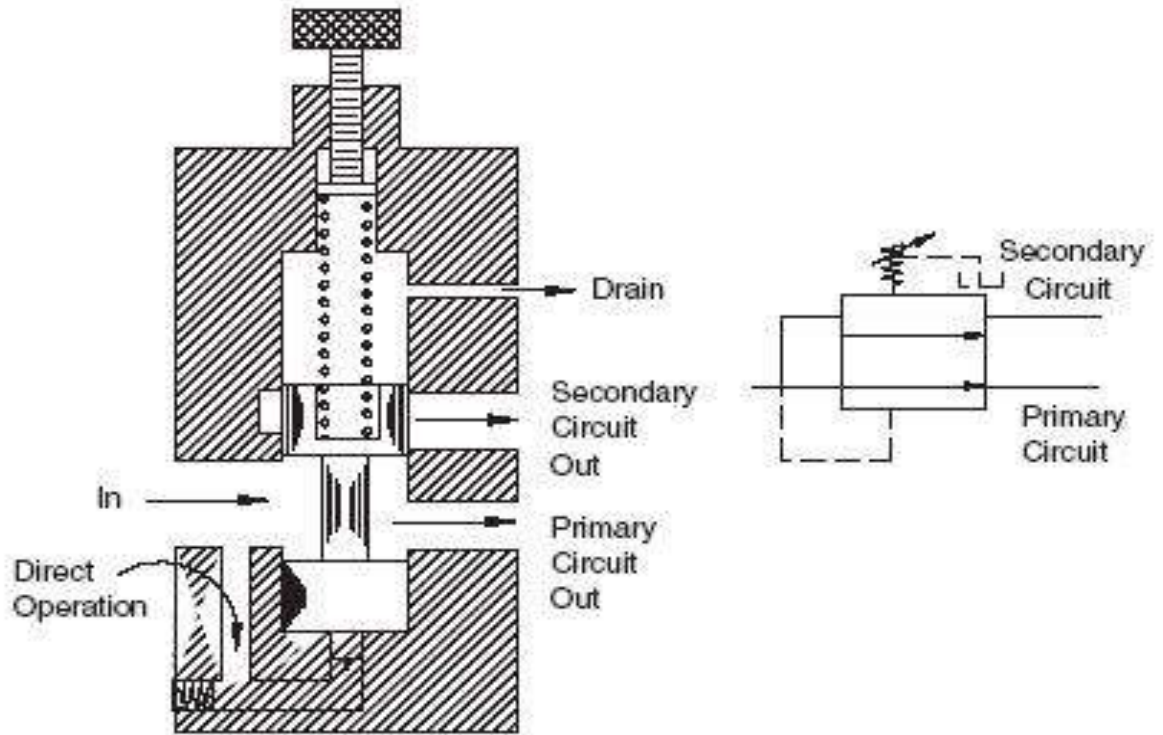

Functional diagram of sequence valve with flow-through to primary circuit.

Video Content / Details of website for further learning (if any):

https://www.youtube.com/results?search_query=Pressure+Reducing+valve+%E2%80%93+Sequence+valve

Important Books/Journals for further learning including the page nos.: 100

Reference Book

Hydraulic and Pneumatic Controls-II Edition, R.Srinivasan, Vijay Nicole Imprints Private Limited, 2006



MUTHAYAMMAL ENGINEERING COLLEGE

(An Autonomous Institution)

(Approved by AICTE, New Delhi, Accredited by NAAC & Affiliated to Anna University)

Rasipuram - 637 408, Namakkal Dist., Tamil Nadu



LECTURE HANDOUTS

L -

Mech

II/IV

Course Name with Code : Applied Hydraulics and Pneumatics

Course Faculty : Dr S.Suresh

Unit : III

Topic of Lecture: Flow Control Valve

Introduction :

- Flow control valves for hydraulic systems (liquids under pressure) are of the same basic design.
- These valves control the amount of flow and will maintain a constant flow at different pressures.
- These valves are ideal for some applications but should be used only when required because of their higher cost.

**Prerequisite knowledge for Complete understanding and learning of Topic:
(Max. Four important topics)**

- Basics of fluid, mechanical, and electrical systems.

Detailed content of the Lecture:

- The purpose of a flow control valve is to regulate the flow rate in a specific portion of a hydraulic circuit.
- In hydraulic systems, they're used to control the flow rate to motors and cylinders, thereby regulating the speed of those components.
- The energy transfer must be equal to the total work done.
- Flow-control valves include simple orifices to sophisticated closed-loop electro hydraulic valves that automatically adjust to variations in pressure and temperature. The purpose of flow control in a hydraulic system is to regulate speed.
- Pressure-compensated flow-control valve. In a 2-port, pressure-compensated proportional flow-control valve.
- An electrically adjustable control orifice is connected in series with a pressure reducing valve spool, known as a compensator

Flow control valves



Adjustable flow control valve



Check valve

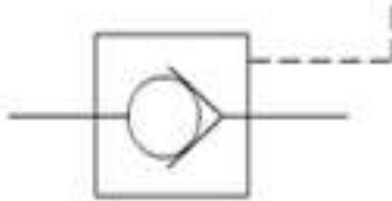

Pilot operated check valve

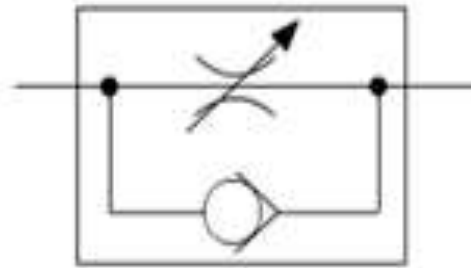

Adjustable flow control with bypass

Video Content / Details of website for further learning (if any):

https://www.youtube.com/results?search_query=Flow+Control+Valve

Important Books/Journals for further learning including the page nos.: 102

Reference Book

Hydraulic and Pneumatic Controls-II Edition, R.Srinivasan, Vijay Nicole Imprints Private Limited, 2006



MUTHAYAMMAL ENGINEERING COLLEGE

(An Autonomous Institution)

(Approved by AICTE, New Delhi, Accredited by NAAC & Affiliated to Anna University)

Rasipuram - 637 408, Namakkal Dist., Tamil Nadu



LECTURE HANDOUTS

L -

Mech

II/IV

Course Name with Code : Applied Hydraulics and Pneumatics

Course Faculty : Dr S.Suresh

Unit : III

Topic of Lecture: Fixed and adjustable –electrical control solenoid valves.

Introduction :

- A solenoid valve is an electromechanically operated valve.
- Solenoid valves differ in the characteristics of the electric current they use, the strength of the magnetic field they generate, the mechanism they use to regulate the fluid, and the type and characteristics of fluid they control.
- The mechanism varies from linear action, plunger-type actuators to pivoted-armature actuators and rocker actuators.
- The valve can use a two-port design to regulate a flow or use a three or more port design to switch flows between ports. Multiple solenoid valves can be placed together on a manifold.

Prerequisite knowledge for Complete understanding and learning of Topic: (Max. Four important topics)

- Basics of fluid, mechanical, and electrical systems.

Detailed content of the Lecture:

- A control valve is a valve used to control fluid flow by varying the size of the flow passage as directed by a signal from a controller.
- This enables the direct control of flow rate and the consequential control of process quantities such as pressure, temperature, and liquid level.
- Solenoid valve function involves either opening or closing an orifice in a valve body, which either allows or prevents flow through the valve.
- A plunger opens or closes the orifice by raising or lowering within a sleeve tube by energizing the coil. Solenoid valves consist of a coil, plunger and sleeve assembly.

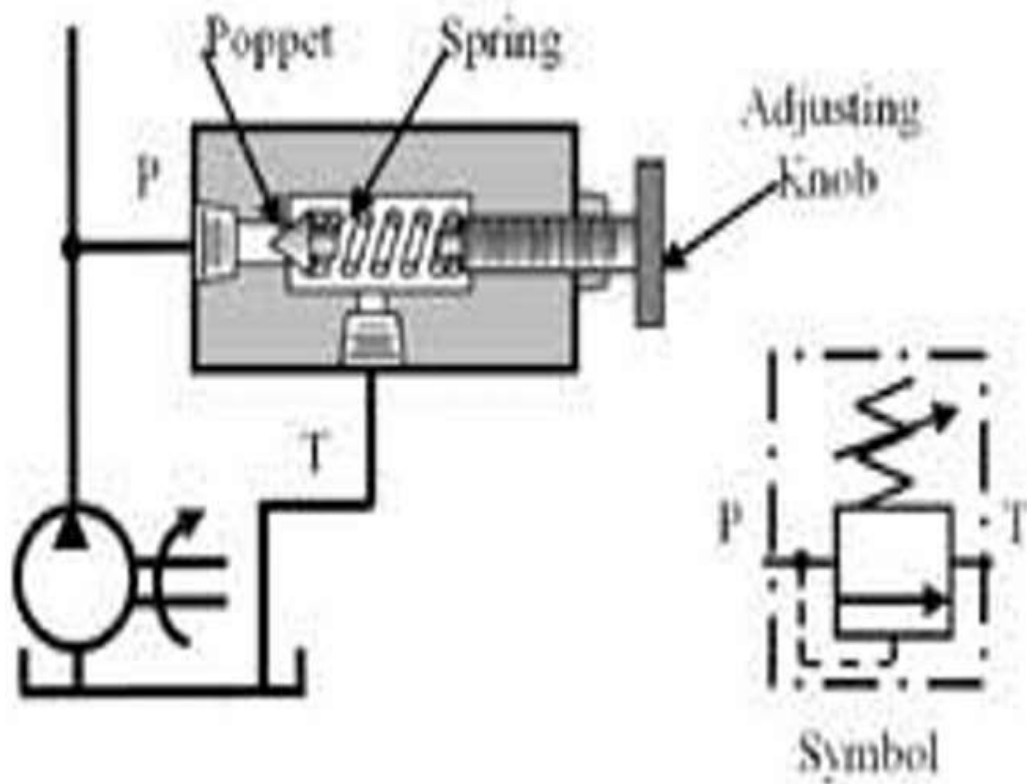

Solenoid Valve

- An electric current through the coil creates a magnetic field.
- The magnetic field exerts a force on the plunger. As a result, the plunger is pulled toward the centre of the coil so that the orifice opens.
- This is the basic principle that is used to open and close solenoid valves.
- Solenoids are most commonly used as electromagnets, and all the examples so far are that kind of solenoid. But there are some other uses. They can be used to slow the flow of electricity in a circuit,

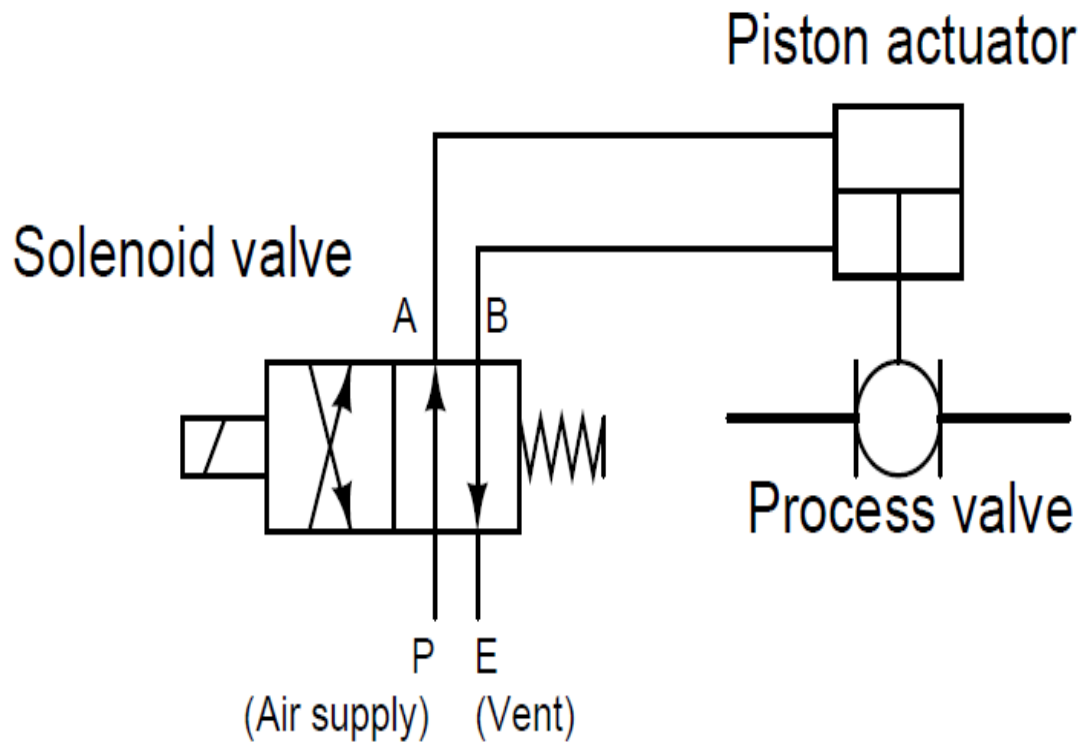

Video Content / Details of website for further learning (if any):

[https://www.youtube.com/results?search_query=electrical+control+solenoid+valves.](https://www.youtube.com/results?search_query=electrical+control+solenoid+valves)

Important Books/Journals for further learning including the page nos.: 333

Reference Book

Hydraulic and Pneumatic Controls-II Edition, R.Srinivasan, Vijay Nicole Imprints Private Limited, 2006



MUTHAYAMMAL ENGINEERING COLLEGE

(An Autonomous Institution)

(Approved by AICTE, New Delhi, Accredited by NAAC & Affiliated to Anna University)

Rasipuram - 637 408, Namakkal Dist., Tamil Nadu



LECTURE HANDOUTS

L -

Mech

II/IV

Course Name with Code : Applied Hydraulics and Pneumatics

Course Faculty : Dr S.Suresh

Unit : III

Topic of Lecture: Relays, Ladder diagram

Introduction :

- Relays are switches that open and close circuits electromechanically or electronically.
- Relays control one electrical circuit by opening and closing contacts in another circuit. As relay diagrams show, when a relay contact is normally open (NO), there is an open contact when the relay is not energized.

Prerequisite knowledge for Complete understanding and learning of Topic:
(Max. Four important topics)

- Basics of fluid, mechanical, and electrical systems.

Detailed content of the Lecture:

Relay Diagram

- It is an electro-magnetic relay with a wire coil, surrounded by an iron core.
- A path of very low reluctance for the magnetic flux is provided for the movable armature and also the switch point contacts.
- The movable armature is connected to the yoke which is mechanically connected to the switch point contacts. These parts are safely held with the help of a spring.
- The spring is used so as to produce an air gap in the circuit when the relay becomes de-energized.

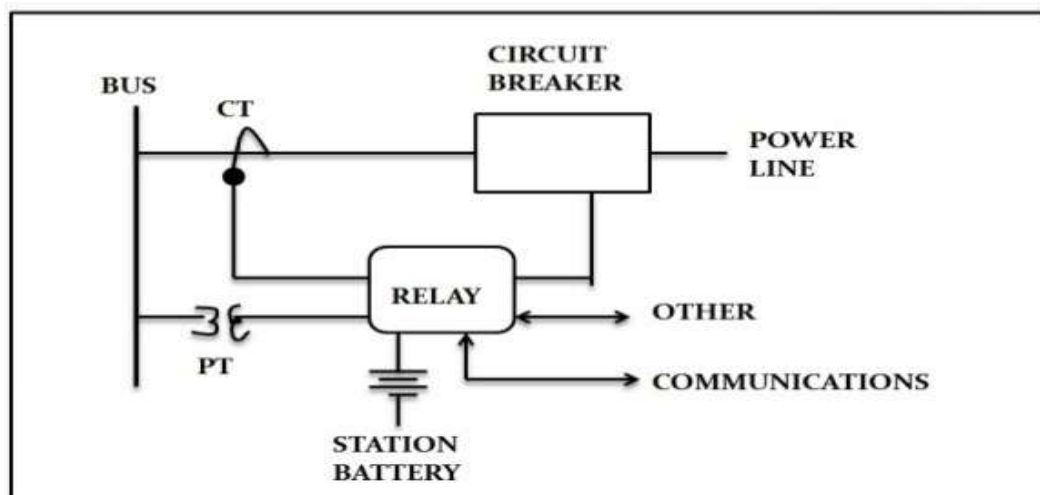

Ladder diagram

- Ladder diagrams are specialized schematics commonly used to document industrial control logic systems.
- They are called “ladder” diagrams because they resemble a ladder, with two vertical rails (supply power) and as many “rungs” (horizontal lines) as there are control circuits to represent.

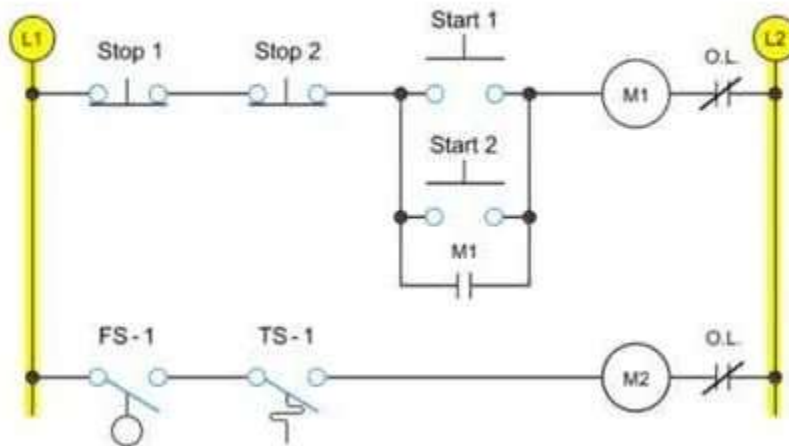

Video Content / Details of website for further learning (if any):

https://www.youtube.com/results?search_query=Relays%2C+Ladder+diagram

Important Books/Journals for further learning including the page nos.: 333,343

Reference Book

Hydraulic and Pneumatic Controls-II Edition, R.Srinivasan, Vijay Nicole Imprints Private Limited ,2006



MUTHAYAMMAL ENGINEERING COLLEGE

(An Autonomous Institution)

(Approved by AICTE, New Delhi, Accredited by NAAC & Affiliated to Anna University)

Rasipuram - 637 408, Namakkal Dist., Tamil Nadu



LECTURE HANDOUTS

L -

Mech

II/IV

Course Name with Code : Applied Hydraulics and Pneumatics

Course Faculty : Dr S.Suresh

Unit : III

Topic of Lecture: Accumulators and Intensifiers

Introduction :

- A hydraulic accumulator is a pressure storage reservoir in which a non-compressible hydraulic fluid is held under pressure that is applied by an external source of mechanical energy.
- The external source can be an engine, a spring, a raised weight, or a compressed gas.
- An accumulator enables a hydraulic system to cope with extremes of demand using a less powerful pump.
- The intensifier is limited by the stroke of the piston. This in turn limits the amount of work that may be done by one stroke of the intensifier.
- These are not reciprocating machines (i.e. continually running multi-stroke machines) and so their entire work must be carried out by a single stroke.
- This limits their usefulness somewhat, to machines that can accomplish their task within a single stroke.

Prerequisite knowledge for Complete understanding and learning of Topic: (Max. Four important topics)

- Basics of fluid, mechanical, and electrical systems.

Detailed content of the Lecture:

Accumulators

- Accumulators can increase efficiency, provide smoother, more reliable operation, and store emergency power in case of electrical failure.
- Accumulators usually are installed in hydraulic systems to store energy and to smooth out pulsations.
- In the central processing unit, or CPU, of a computer, the accumulator acts as a special register that stores values and increments of intermediate arithmetic and logic calculations.
- The accumulator is a temporary **memory** location that is accessed speedily by the CPU.

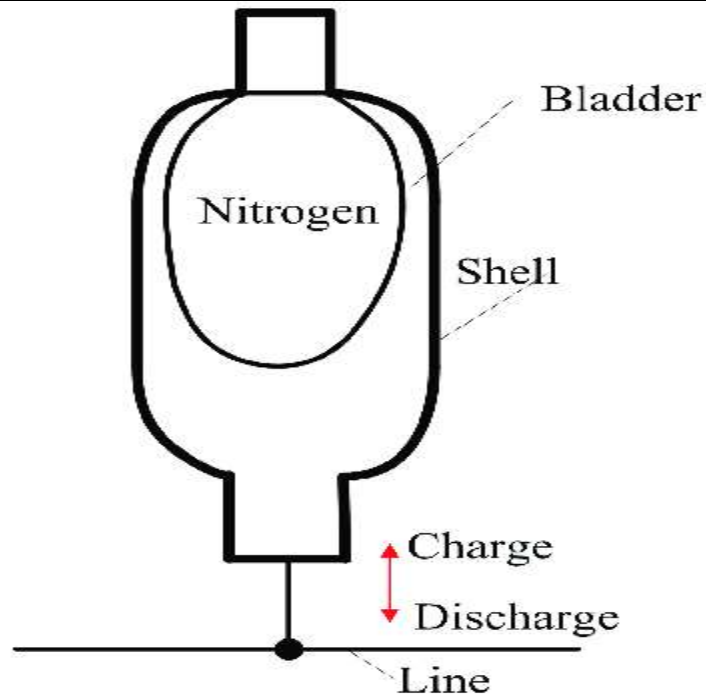

Intensifiers

- A hydraulic intensifier is a device which is used to increase the intensity of pressure of any hydraulic fluid or water, with the help of the hydraulic energy available from a huge quantity of water or hydraulic fluid at a low pressure.
- A hydraulic intensifier is a hydraulic machine for transforming hydraulic power at low pressure into a reduced volume at higher pressure..

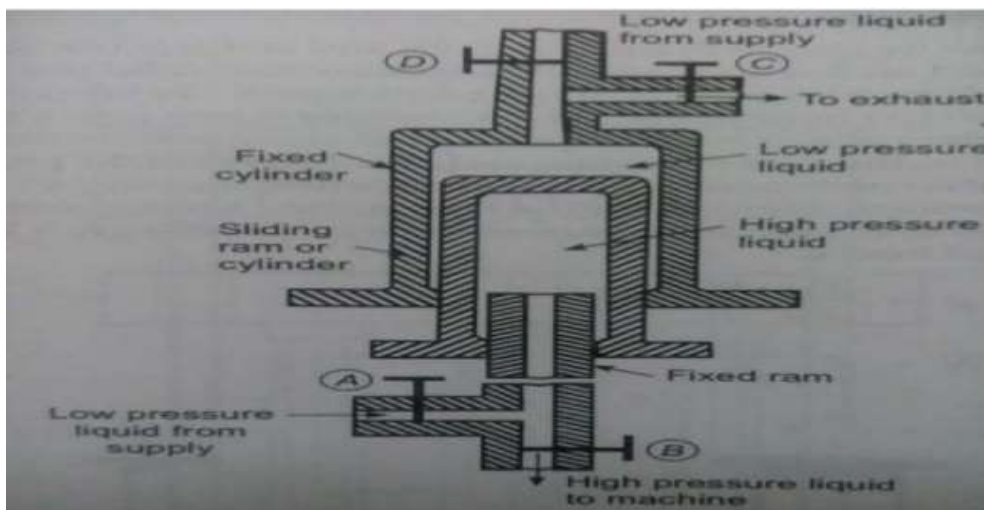

Video Content / Details of website for further learning (if any):

https://www.youtube.com/results?search_query=Accumulators+and+Intensifiers

Important Books/Journals for further learning including the page nos.: 137

Reference Book

Hydraulic and Pneumatic Controls-II Edition, R.Srinivasan, Vijay Nicole Imprints Private Limited ,2006



LECTURE HANDOUTS

L -

Mech

II/IV

Course Name with Code : Applied Hydraulics and Pneumatics

Course Faculty : Dr S.Suresh

Unit : III

Topic of Lecture: Accumulators and Intensifiers circuits

Introduction :

- A Hydraulic Accumulator the external source used can be a spring, a raised weight, or a compressed gas.
- It is pressure storage reservoir in which a non- compressible hydraulic fluid is held under pressure by an external source is energy storage device.
- A large quantity of water at a low pressure from the supply enters the inverted fixed cylinder. The weight of this water presses the sliding cylinder in the downward direction.

Prerequisite knowledge for Complete understanding and learning of Topic: (Max. Four important topics)

- Basics of fluid, mechanical, and electrical systems.

Detailed content of the Lecture:

Accumulators circuits

- The term "accumulator" is used in a wide variety of non computing applications and activities, such as electrical engineering (an energy storage device such as a rechargeable battery or ultra capacitor), hydraulics (a mechanical energy storage device)
- The piston or bladder moves and compresses the gas volume because fluid pressure exceeds the pre charge pressure. This is the source of stored energy.

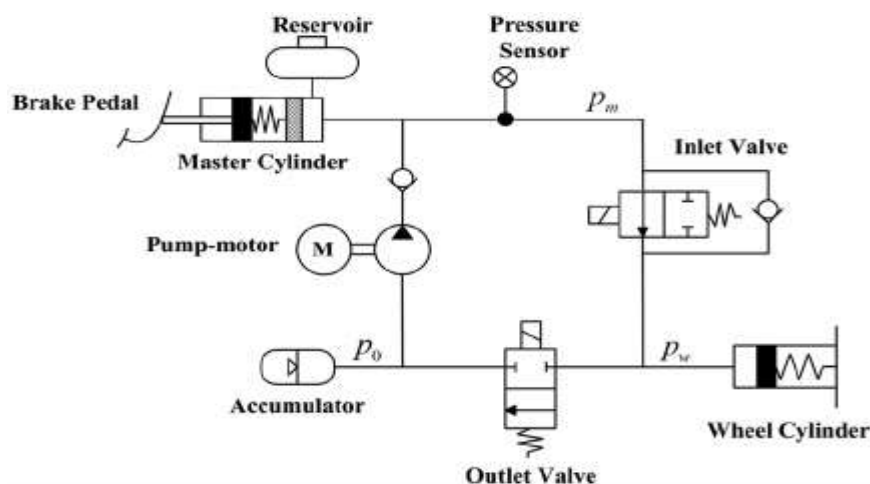

Intensifiers circuits

- Pressure- or fatigue-testing machines often require high pressure for long periods of time.
- Another choice for low-volume/high-pressure *circuits* is an *intensifier*.
- When a *circuit* calls for a small volume of high-pressure oil or air, consider using an *intensifier* – sometimes called a booster.

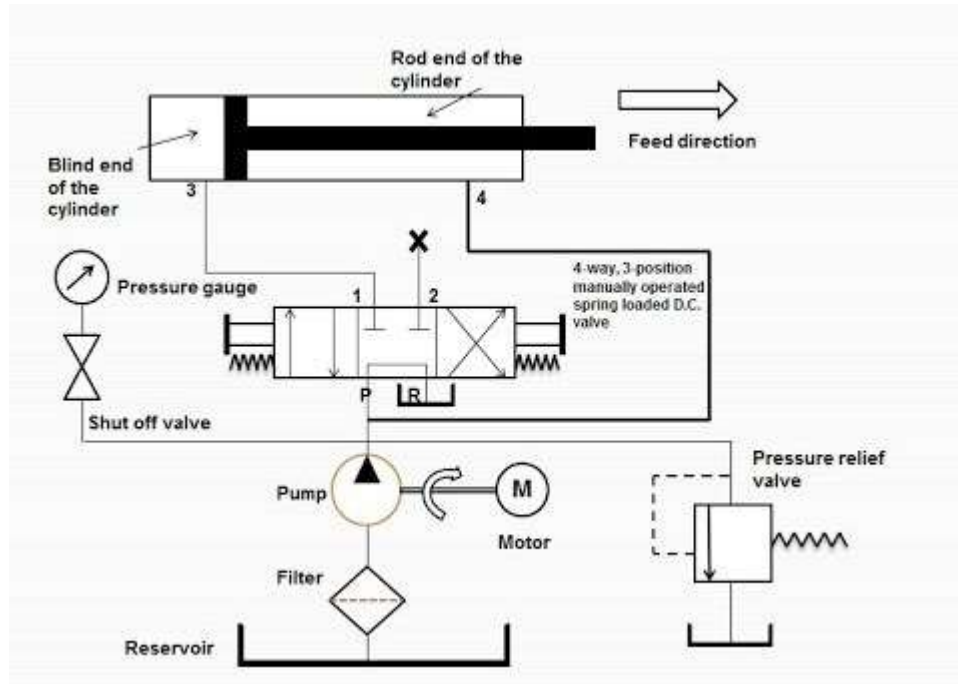

Video Content / Details of website for further learning (if any):

https://www.youtube.com/results?search_query=Accumulators+and+Intensifiers+circuits

Important Books/Journals for further learning including the page nos.: 144,169

Reference Book

Hydraulic and Pneumatic Controls-II Edition, R.Srinivasan, Vijay Nicole Imprints Private Limited ,2006



LECTURE HANDOUTS

L -

Mech

II/IV

Course Name with Code : Applied Hydraulics and Pneumatics

Course Faculty : Dr S.Suresh

Unit : III

Topic of Lecture: Sizing of Accumulators and application of Intensifiers circuits

Introduction :

- Accumulators are selected based on the fluid pressure and volume requirements of the system which they are to be installed into.
- The accumulator is sized such that the system fluid pressure will not fall below a value resulting in degraded system performance.

Prerequisite knowledge for Complete understanding and learning of Topic:
(Max. Four important topics)

- Basics of fluid, mechanical, and electrical systems.

Detailed content of the Lecture:

Sizing of Accumulators

- Accumulators can increase efficiency, provide smoother, more reliable operation, and store emergency power in case of electrical failure.
- Accumulators also can act as surge or pulsation absorbers, much as an air dome is used on pulsating piston or rotary pumps.
- Accumulators will cushion hydraulic hammer, reducing shocks caused by rapid operation or sudden starting and stopping of power cylinders in a hydraulic circuit.

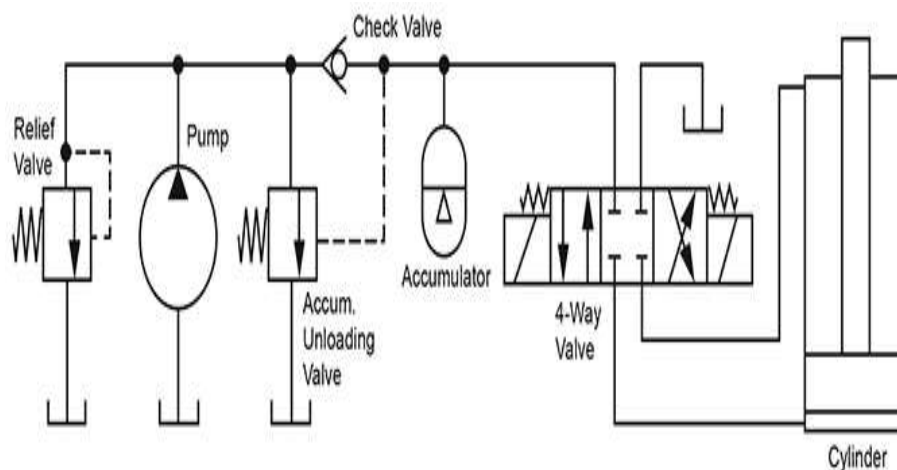

Application of intensifiers circuits

- Pressure intensifiers can be applied to a host of diverse applications such as hydraulic work holding, pressure die casting, static and impulse testing equipment, hydraulic power packs, intensifier panels for subsea ROV's, hydraulic operated tools, and more.
- Air operated Hydraulic intensifiers are used commonly for clamping, holding, punching, presses and torque etc

Video Content / Details of website for further learning (if any):

<https://www.hydraulicspneumatics.com/technologies/other-technologies/article/21884186/chapter-16-accumulators>

Important Books/Journals for further learning including the page nos.: 147

Reference Book

Hydraulic and Pneumatic Controls-II Edition, R.Srinivasan, Vijay Nicole Imprints Private Limited ,2006



MUTHAYAMMAL ENGINEERING COLLEGE

(An Autonomous Institution)

(Approved by AICTE, New Delhi, Accredited by NAAC & Affiliated to Anna University)

Rasipuram - 637 408, Namakkal Dist., Tamil Nadu



LECTURE HANDOUTS

L-1

MECH

II/IV

Course Name with Code : Applied Hydraulics and Pneumatics

Course Faculty : Dr S.Suresh

Unit : IV

Topic of Lecture: Pneumatic Components: Properties of air

Introduction : (Maximum 5 sentences)

- Atmospheric air makes up the environment in almost every type of pneumatic system.
- Hence a thorough understanding of the properties of atmospheric air is fundamental to pneumatic system design.

Prerequisite knowledge for Complete understanding and learning of Topic:

Fluid mechanics, Fluid machineries

Detailed content of the Lecture:

- Air is a mixture of gaseous elements and compounds.
- These include nitrogen, oxygen, water, argon, and carbon dioxide

Air has weight. Because the weight of air varies with pressure and temperature it has to be defined accurately. The following figures may be used. The weight of dry air (no moisture content) at 0 deg C and under a normal atmospheric pressure of 1013 mbar is 1.293 kg/m³. The weight of dry air (no moisture content) at 0 deg C and at a pressure of 1000 mbar (1 Bar) is 1.275 kg/m³.

Air is under pressure. Air is under pressure; this is caused by gravity. Air pressure at sea level is approximately 1013 mbar, which is about the same as 14.7 psi. The reason for this pressure is because there is so much air stacked up on top of it. If you were higher up, say in an airplane, the air pressure outside the plane would be much lower. We know that the air pressure at 18,000 ft. (about 5500 meters) is approximately half that at sea level. At 32,000 ft. (about 10,000 meters) the air pressure is only a quarter of that at sea level. The reason for the reduction in pressure is because there is less air stacked up on top at these high altitudes.

- Air pressure is all around us as we live under a "sea of air" - a bit like a fish surrounded by a sea of water.
- The air presses on us from all sides, but we are so used to it we don't feel it. Every part of our body is pushing back (each cell is like a balloon) so we don't get squashed flat.

Air has temperature. Like most things around us, air expands when it gets hot and contracts when it gets cold. Temperature has an effect on Volume, and that Volume has an effect on Pressure.

Air has a volume. Air occupies a specific volume. This volume is inter-related with pressure and temperature. If you squeeze air into a smaller space the air gets hotter. This is easily demonstrated when you pump up a bicycle tire. The harder you pump, the hotter the air gets and the hotter the hand pump gets. Because the amount of air contained within a box will vary with temperature and pressure, it is necessary to qualify the temperature and pressure.

Air usually contains some water vapor. Air behaves a bit like a sponge, if there's any water around it will try to absorb it. Like a sponge it can only hold just so much water before it becomes saturated. Again like a sponge, if you squeeze it (compress it) the water will drip out. A dry sponge doesn't have any water in it; therefore it has a relative humidity of 0%. A soaking wet sponge can't take in any more water because it's already saturated. Therefore this sponge has a relative humidity of 100%.

Air usually has some velocity (speed). You can see this every day, leaves getting whipped up by the breeze and being blown down a road. Outside air velocity is a function of wind strength. The velocity of air in a room may be low at 0.25 m/s or much higher in a compressed air pipe.

Web link :

[https://en.wikibooks.org/wiki/Science: An Elementary Teacher%E2%80%99s Guide/Properties of Air](https://en.wikibooks.org/wiki/Science:_An_Elementary_Teacher%E2%80%99s_Guide/Properties_of_Air)

Important Books/Journals for further learning including the page nos.:

Hydraulic and Pneumatic Controls-II Edition, R.Srinivasan, Vijay Nicole Imprints Private Limited, pp: 250

LECTURE HANDOUTS

L-

MECH

II/IV

Course Name with Code : Applied Hydraulics and Pneumatics

Course Faculty : Dr S.Suresh

Unit : IV

Topic of Lecture: Compressors – Filter, Regulator, and Lubricator Unit

Introduction : (Maximum 5 sentences)

- An **FRL unit** is comprised of a filter (F), regulator (R), and a lubricator (L). They are often used as one **unit** to ensure clean air in a **pneumatic system** but can also be used individually.

Prerequisite knowledge for Complete understanding and learning of Topic:

Fluid mechanics, Fluid machineries

Detailed content of the Lecture:

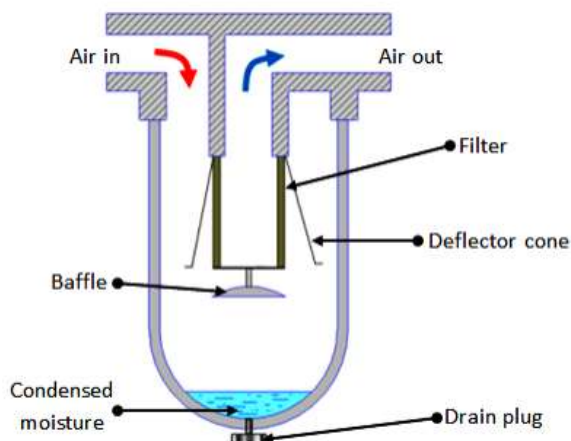

Air filter

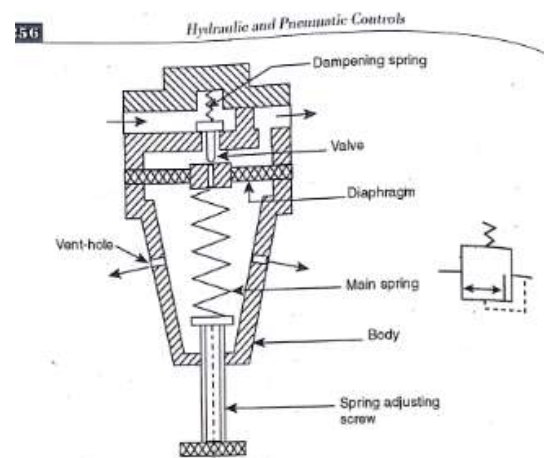

Regulator

- An air line filter cleans compressed air.
- It strains the air and traps solid particles (dust, dirt, rust) and separates liquids (water, oil) entrained in the compressed air.
- Filters are installed in the air line upstream of regulators, lubricators, directional control valves, and air driven devices such as cylinders and air motors.
- Air line filters remove contaminants from pneumatic systems, preventing damage to equipment and reducing production losses due to contaminant related downtime.
- Downtime in an industrial plant is expensive; often it is the result of a contaminated and poorly maintained compressed air system.

Pressure regulators

- Pressure regulators reduce and control fluid pressure in compressed air systems.
- Regulators are also frequently referred to as PRVs (pressure reducing valves).
- Optimally, a pressure regulator maintains a constant output pressure regardless of variations in the input pressure and downstream flow requirements.
- In practice, output pressure is influenced to some degree by variations in primary pressure and flow.

Lubricator

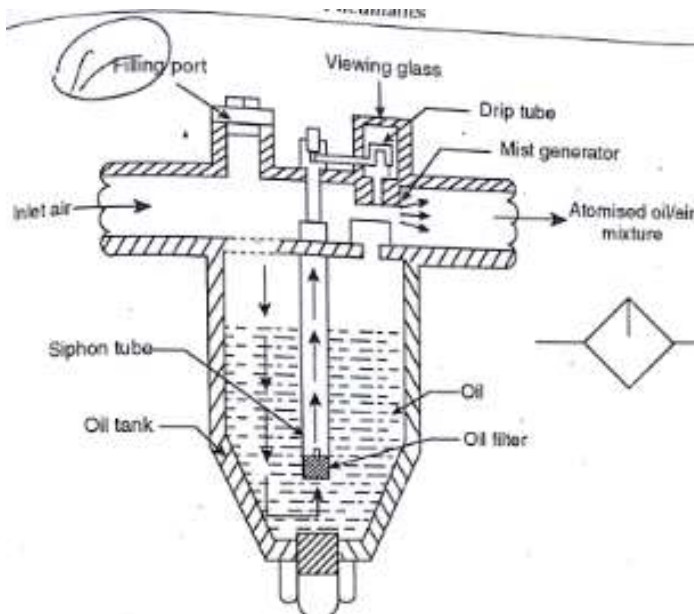

- A lubricator adds controlled quantities of oil into a compressed air system to reduce the friction of moving components.
- Most air tools, cylinders, valves, air motors, and other air driven equipment require lubrication to extend their useful life.
- The use of an airline lubricator solves the problems of too much or too little lubrication that arise with conventional lubrication methods such as a grease gun or oil.
- Once the lubricator is adjusted, an accurately metered quantity of lubricant is supplied to the air operated equipment and the only maintenance required is a periodic refill of the lubricator reservoir.
- Adding lubrication to a system also “washes away” compressor oils that travel through the system in vapor form.

Web link :

<https://nptel.ac.in/content/storage2/courses/112103174/pdf/mod6.pdf>

Important Books/Journals for further learning including the page nos.:

Hydraulic and Pneumatic Controls-II Edition, R.Srinivasan, Vijay Nicole Imprints Private Limited, pp: 255-256



MUTHAYAMMAL ENGINEERING COLLEGE

(An Autonomous Institution)

(Approved by AICTE, New Delhi, Accredited by NAAC & Affiliated to Anna University)

Rasipuram - 637 408, Namakkal Dist., Tamil Nadu



LECTURE HANDOUTS

L-

MECH

II/IV

Course Name with Code : Applied Hydraulics and Pneumatics

Course Faculty : Dr S.Suresh

Unit : IV

Topic of Lecture: Air control valves, Quick exhaust valves

Introduction : (Maximum 5 sentences)

- Control valves operated through pneumatic actuators can be either (i) air to open, or (ii) air to close.
- They are designed such that if the air supply fails, the control valve will be either fully open, or fully closed, depending upon the safety requirement of the process

Prerequisite knowledge for Complete understanding and learning of Topic:

Fluid mechanics, Fluid machineries

Detailed content of the Lecture:

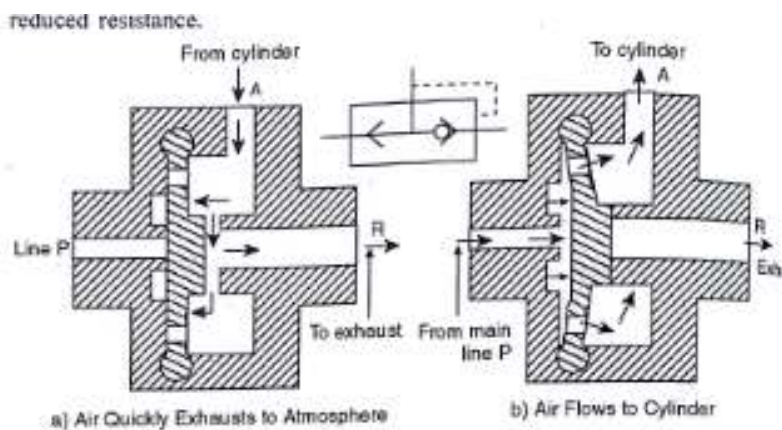

In a typical application, the exhaust valve is installed in the inlet of a spring return or double acting pneumatic cylinder. Supply air from a control valve is directed into the inlet port of the exhaust valve. The nitrile poppet seals the exhaust port and allows air to flow from the outlet port of the valve into the cylinder. The pressurized air then pushes against the piston and extends the rod, compressing the spring, until full rod extension is achieved.

When the control valve exhausts air from the exhaust valve inlet port, the nitrile poppet shifts to seal the inlet port and open the exhaust port to the cylinder. The pressurized air is then

allowed to exhaust directly through the exhaust valve to atmosphere. Normally the air must travel back through the long air line to the control valve to exhaust. However, by mounting the exhaust valve directly on the cylinder, the piston retracts quickly since the distance to atmosphere is very short and unrestricted.

Web link :

[https://nptel.ac.in/content/storage2/courses/108105063/pdf/L-25\(SS\)\(IAC\)%20\(\(EE\)NPTEL\).pdf](https://nptel.ac.in/content/storage2/courses/108105063/pdf/L-25(SS)(IAC)%20((EE)NPTEL).pdf)

Important Books/Journals for further learning including the page nos.:

Hydraulic and Pneumatic Controls-II Edition, R.Srinivasan, Vijay Nicole Imprints Private Limited, pp: 257-261



MUTHAYAMMAL ENGINEERING COLLEGE

(An Autonomous Institution)

(Approved by AICTE, New Delhi, Accredited by NAAC & Affiliated to Anna University)

Rasipuram - 637 408, Namakkal Dist., Tamil Nadu



LECTURE HANDOUTS

L-

MECH

II/IV

Course Name with Code : Applied Hydraulics and Pneumatics

Course Faculty : Dr S.Suresh

Unit : IV

Topic of Lecture: Pneumatic Actuators

Introduction : (Maximum 5 sentences)

- Function of pneumatic actuator is to convert the pressure energy of compressed air energy into mechanical energy to perform useful work.
- We can classify the linear actuator as linear actuators, rotary actuators

Prerequisite knowledge for Complete understanding and learning of Topic:

Fluid mechanics, Fluid machineries

Detailed content of the Lecture:

- Pneumatic cylinders can be used to get linear, rotary and oscillatory motion. There are three types of pneumatic actuator: they are
 - i) Linear Actuator or Pneumatic cylinders
 - ii) Rotary Actuator or Air motors
 - iii) Limited angle Actuators

The different classification scheme of the pneumatic cylinders are given below

1. Based on application for which air cylinders are used

- i) Light duty air cylinders
- ii) Medium duty air cylinders
- iii) Heavy duty air cylinders

2. Based on the cylinder action

- i) Single acting cylinder
 - ii) Double acting cylinder
- Single rod type double acting cylinder
 Double rod type double acting cylinder

3. Based on cylinder's movement

- i) Rotating type air cylinder
- ii) Non rotating type air cylinder

4. Based on the cylinder's design

- i) Telescopic cylinder
- ii) Tandem cylinder
- iii) Rod less cylinder
- Cable cylinder,
- Sealing band Cylinder with slotted cylinder barrel
- Cylinder with Magnetically Coupled Slide
- iv) Impact cylinder
- v) Duplex cylinders

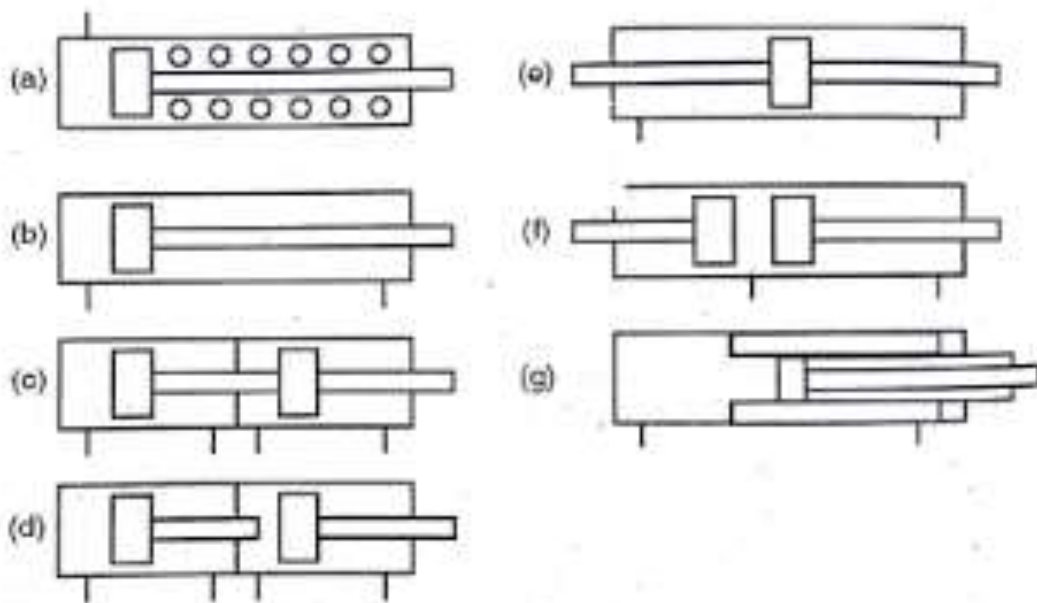

Figure 12.16 Basic Cylinder Types a) Single Acting Cylinder b) Double Acting Cylinder
 c) Tandem Cylinder d) Three Position Cylinder e) Through Rod Cylinder
 f) Adjustable Stroke Cylinder g) Telescoping Cylinder

Web link :

https://mechanicalengineering120.files.wordpress.com/2017/11/lecture-37_pneumatics-actuators.pdf

Important Books/Journals for further learning including the page nos.:

Hydraulic and Pneumatic Controls-II Edition, R.Srinivasan, Vijay Nicole Imprints Private Limited, pp: 263-266



MUTHAYAMMAL ENGINEERING COLLEGE

(An Autonomous Institution)

(Approved by AICTE, New Delhi, Accredited by NAAC & Affiliated to Anna University)

Rasipuram - 637 408, Namakkal Dist., Tamil Nadu



LECTURE HANDOUTS

L-5

MECH

II/IV

Course Name with Code : Applied Hydraulics and Pneumatics

Course Faculty : Dr S.Suresh

Unit : IV

Topic of Lecture: Fluid Power Circuit Design

Introduction : (Maximum 5 sentences)

- Pneumatic technology deals with the study of behavior and applications of compressed air in our daily life in general and manufacturing automation in particular

Prerequisite knowledge for Complete understanding and learning of Topic:

Fluid mechanics, Fluid machineries

Detailed content of the Lecture:

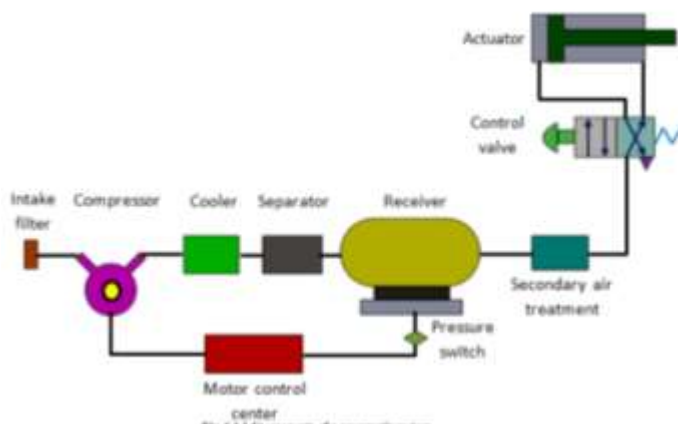

Important components of a pneumatic system are

- a) Air filters: These are used to filter out the contaminants from the air.
- b) Compressor: Compressed air is generated by using air compressors. Air compressors are either diesel or electrically operated. Based on the requirement of compressed air, suitable capacity compressors may be used.
- c) Air cooler: During compression operation, air temperature increases. Therefore coolers

are used to reduce the temperature of the compressed air.

d) Dryer: The water vapor or moisture in the air is separated from the air by using a dryer.

e) Control Valves: Control valves are used to regulate, control and monitor for control of direction flow, pressure etc.

f) Air Actuator: Air cylinders and motors are used to obtain the required movements of mechanical elements of pneumatic system.

g) Electric Motor: Transforms electrical energy into mechanical energy. It is used to drive the compressor.

h) Receiver tank: The compressed air coming from the compressor is stored in the air receiver.

Web link :

<https://nptel.ac.in/content/storage2/courses/112103174/pdf/mod6.pdf>

Important Books/Journals for further learning including the page nos.:

Hydraulic and Pneumatic Controls-II Edition, R.Srinivasan, Vijay Nicole Imprints Private Limited, pp: 271



MUTHAYAMMAL ENGINEERING COLLEGE

(An Autonomous Institution)

(Approved by AICTE, New Delhi, Accredited by NAAC & Affiliated to Anna University)

Rasipuram - 637 408, Namakkal Dist., Tamil Nadu



LECTURE HANDOUTS

L-

MECH

II/IV

Course Code with Code : Applied Hydraulics and Pneumatics

Course Faculty : Dr S.Suresh

Unit : IV

Topic of Lecture: Speed control circuits

Introduction : (Maximum 5 sentences)

- In some applications, there are times when it is necessary to vary the speed of an actuator.
- One method of controlling an actuator's speed is by using a variable-volume pump

Prerequisite knowledge for Complete understanding and learning of Topic:

Fluid mechanics, Fluid machineries

Detailed content of the Lecture:

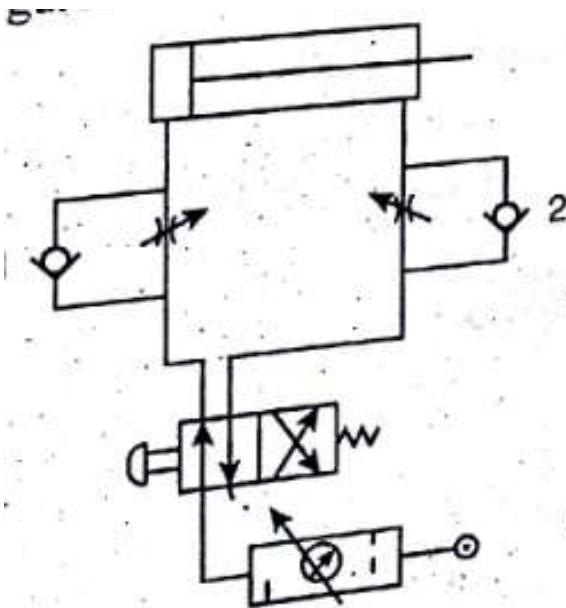

- Meter-In flow control circuit restricts fluid as it enters an actuator port. Meter-in circuits works well with hydraulic fluids, but can give erratic action with air.
- A meter-out flow control circuit that restricts fluid as it leaves an actuator port.

Working principle

- In meter out circuit, the flow control valve is installed in the return line metering the fluid being discharged. In that way, this circuit also gives the control over the actuating speed.
- But this way of control offers altogether different characteristics to the circuit. Now, the circuit pressure has to overcome the load resistance and the pressure drop across the flow control valve.
- However, as the flow control valve is on the right side of the piston, the differential area will cause rise in the pressure. This increased pressure helps to overcome the pressure drop across the flow control valve.
- As the system pressure required will be relatively low, it makes this circuit marginally more efficient on the extend stroke. Initially, the compensatory spool is fully open, and full pump flow is passed into the cylinder until piston moves forward building up pressure at the flow control valve.
- The compensatory spool will now come into operation and restricts the flow to its correct value. Thus, there is an initial flow surge before the compensatory spool adjusts as in the case of 'meter-in' When using meter-out system, the pressure in the rod-end of the cylinder must be carefully considered. With meter-out speed control, the quantity of oil leaving the cylinder is controlled.
- When the cylinder is extending, the oil from the rod-end is metered which a smaller quantity than that is flowing into the full bore end. Consequently, under extend conditions; meter-out flow control is not as sensitive as meter-in control.
- When the cylinder is retracting, the reverse is true. Meter-out circuits are best where negative loads may occur, because back pressure is maintained on the exhaust side of the actuator preventing erratic motion. Meter-out circuits provide accurate speed control even with reversing loads.
- However, as with the meter-in system, considerable heat will be generated when used with a fixed delivery pump and a wide range of piston speeds. Applications: Drilling, Boring, Reaming and tapping operations.
- In meter in circuit the restriction is given in the flow inlet line to the piston head side of the cylinder. So the air flow inside slowly and when it comes out of the cylinder through the return valve it comes out at higher speed than the air inlet speed.

Web link :

https://nptel.ac.in/content/storage2/nptel_data3/html/mhrd/ict/text/112105047/lec37.pdf

Important Books/Journals for further learning including the page nos.:

Hydraulic and Pneumatic Controls-II Edition, R.Srinivasan, Vijay Nicole Imprints Private Limited, pp: 271



LECTURE HANDOUTS

L-

MECH

II/IV

Course Name with Code : Applied Hydraulics and Pneumatics

Course Faculty : Dr S.Suresh

Unit : IV

Topic of Lecture: Synchronizing Circuit

Introduction : (Maximum 5 sentences)

- Some machines with multiple cylinders require that the cylinder strokes be perfectly synchronized for the machine to operate properly.
- If all the loads, line sizes and lengths, and friction of the cylinders and machine members are identical, they may stroke at the same time and rate

Prerequisite knowledge for Complete understanding and learning of Topic:

Fluid mechanics, Fluid machineries

Detailed content of the Lecture:

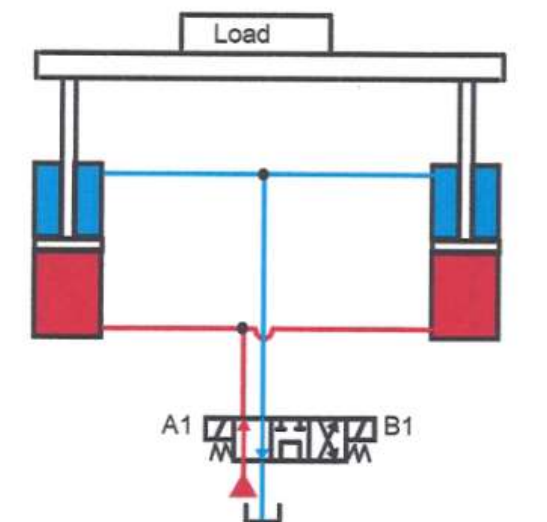

- The most accurate way to synchronize hydraulic cylinders is with servo valves.
- Servo valves independently control each cylinder with electronic position feedback, and compare each actuator's position with all others.
- This is the most expensive way to synchronize cylinders but the most accurate.
- Actuator position within ± 0.001 to 0.002 in. of each other is attainable using good servo practices. (This type of synchronizing also works well with cylinders that never go to a home position.)

- The circuit in Figure has no controls except the directional valve.
- If the pipes are all the same relative size and all the same length; if the load is centered; and if friction of all parts is identical, the cylinders might travel exactly together.
- Some of these variables are controllable, but things like friction may change even during a single cycle. With the setup in Figure, the cylinders actually move one at a time until they hit end of stroke or bind up mechanically.

An example for synchronizing circuit

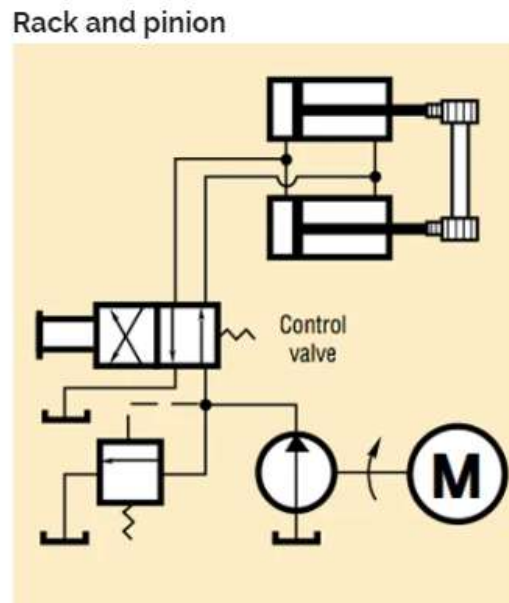

Web link : <https://www.hydraulicspneumatics.com/technologies/other-technologies/article/21884338/book-2-chapter-22-synchronizing-cylinder-movement#:~:text=Synchronizing%20Cylinder>

Important Books/Journals for further learning including the page nos.:

Hydraulic and Pneumatic Controls-II Edition, R.Srinivasan, Vijay Nicole Imprints Private Limited, pp: 173



LECTURE HANDOUTS

L-

MECH

II/IV

Course Name with Code : Applied Hydraulics and Pneumatics

Course Faculty : Dr S.Suresh

Unit : IV

Topic of Lecture: Penumo hydraulic circuit

Introduction : (Maximum 5 sentences)

- Pneumo-hydraulic control units, constituted by a pneumatic cylinder with a hydraulic circuit integrated inside the piston rod, permit a precise speed regulation and a simple, sturdy and reliable motion control.

Prerequisite knowledge for Complete understanding and learning of Topic:

Fluid mechanics, Fluid machineris

Detailed content of the Lecture:

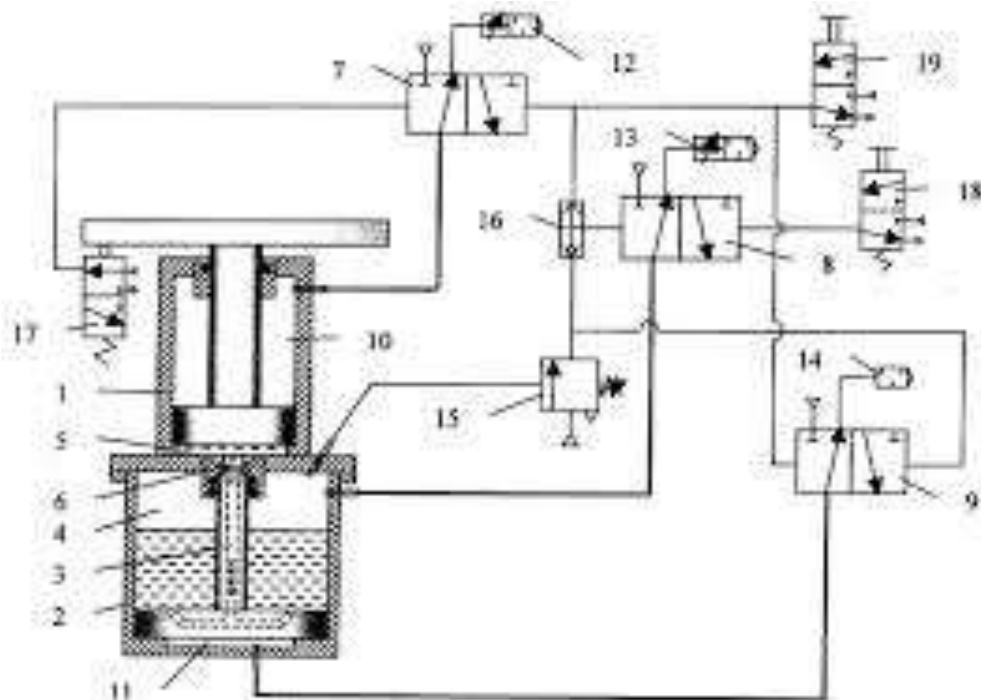

- The design features of this product represent the summary of two applied techniques: compressed air as driving power and hydraulic system as fluid control.
- The combination of these two technologies allows operating these actuators with the simplicity of a standard pneumatic cylinder but with possible precise motion control assured by the hydraulic system, without needing bulky and expensive outer control units.

- Pneumo-hydraulic control units, constituted by a pneumatic cylinder with a hydraulic circuit integrated inside the piston rod, permit a precise speed regulation and a simple, sturdy and reliable motion control.
- The actuators proposed by Bonesi Pneumatik are made up by a double-acting pneumatic cylinder with a closed circuit coaxially integrated for the oil recirculation, housed inside the piston rod.
- The piston rod of the unit, with increased diameter compared with the one of a standard pneumatic cylinder, is made with a high-strength steel tube, chrome-plated outside.
- Inside the piston rod, the uses of two tubes with inferior differentiated sections allow obtaining two hermetically sealed chambers, containing the oil of the hydraulic circuit.
- Owing to the motion of the pneumatic piston, controlled by normal five-way directional solenoid valves, the oil contained in the circuit is subjected to circulation between the two chambers and is made flow through the control group, positioned on board of the cylinder or externally, with the aid of hydraulic tubes.
- The piston rod motion speed, in the forward and/or return stroke, can be regulated precisely and uniformly by the insertion of one or two unidirectional flow governors.
- It is possible to reach approximate minimum speeds of 0.5 mm/s, anyway maintaining a smooth constant motion, irrespective of workload variations and the feeding pressure of the pneumatic circuit.

Web link :

<https://www.powertransmissionworld.com/pneumo-hydraulic-control-units/#:~:text=Pneumo-hydraulic%20control%20units%2C%20constituted,sturdy%20and%20reliable%20motion%20c>

Important Books/Journals for further learning including the page nos.:

Hydraulic and Pneumatic Controls-II Edition, R.Srinivasan, Vijay Nicole Imprints Private Limited, pp: 274



MUTHAYAMMAL ENGINEERING COLLEGE

(An Autonomous Institution)

(Approved by AICTE, New Delhi, Accredited by NAAC & Affiliated to Anna University)

Rasipuram - 637 408, Namakkal Dist., Tamil Nadu



LECTURE HANDOUTS

L-

MECH

II/IV

Course Name with Code : Applied Hydraulics and Pneumatics

Course Faculty : Dr S.Suresh

Unit : IV

Topic of Lecture: Sequential circuit design for simple applications using cascade method.

Introduction : (Maximum 5 sentences)

- Cascading is similar to that for electromechanical devices.
- It involves dividing the sequence into groups with each group's manifold (power or main pressure line) being supplied with pneumatic power (pressure) one at a time and in sequence.
- Motion within each group is powered by its own group manifold.

Prerequisite knowledge for Complete understanding and learning of Topic:

Fluid mechanics, Fluid machineries

Detailed content of the Lecture:

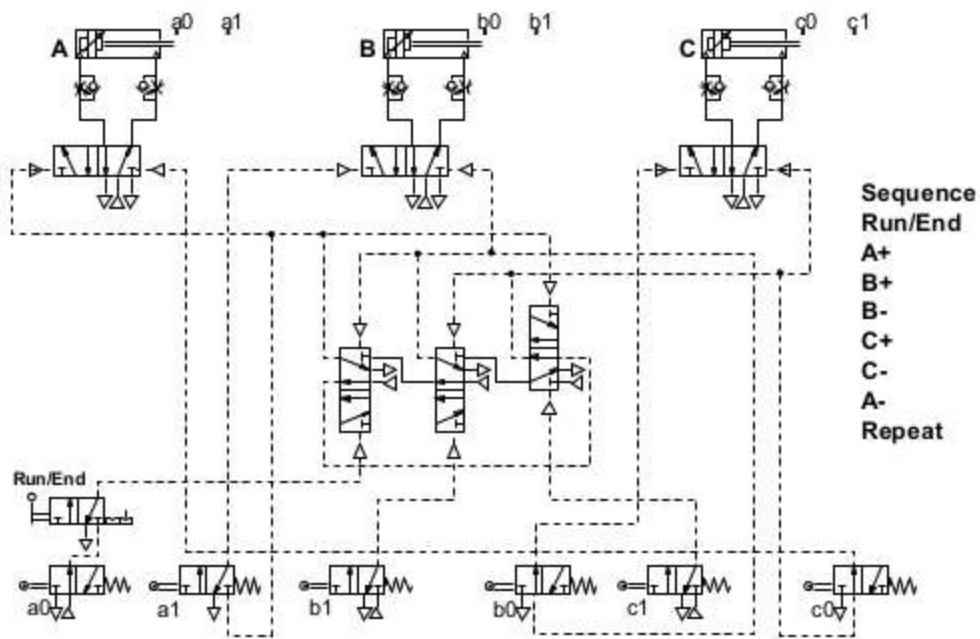

Web link : <https://www.scribd.com/doc/70755148/Basic-Pneumatic-Cascade>

Important Books/Journals for further learning including the page nos.:

Hydraulic and Pneumatic Controls-II Edition, R.Srinivasan, Vijay Nicole Imprints Private Limited, pp: 315-317



MUTHAYAMMAL ENGINEERING COLLEGE

(An Autonomous Institution)

(Approved by AICTE, New Delhi, Accredited by NAAC & Affiliated to Anna University)

Rasipuram - 637 408, Namakkal Dist., Tamil Nadu



LECTURE HANDOUTS

L

MECH

II/IV

Course Name with Code : 16MED10 APPLIED HYDARULICS AND PNUEMATICS

Course Faculty : Dr S.Suresh

Unit : V

Topic of Lecture: Servo system -Hydro Mechanical servo system

Introduction : (Maximum 5 sentences)

A servo valve is a direction control valve which has infinite variable positioning capability. Thus it can control not only the direction of fluid flow but also the amount. Servo valves are coupled with feedback sensing devices and thus a very accurate control of position, velocity and acceleration of an actuator can be obtained.

**Prerequisite knowledge for Complete understanding and learning of Topic:
(Max. Four important topics)**

Direction Control valves, mechanical and electrical systems

Detailed content of the Lecture:

Diagram/ Description/Algorithm/Procedure for solving problems/ Derivation component with supporting content if any

Figure 1 shows a mechanical hydraulic servo system with automotive power steering, the sequential operation of which occurs as follows:

- The input or command signals are the turning of the steering wheel.
- This results in movement of the valve sleeve, which ports oil to the actuator (steering cylinder).
- The piston rod moves the wheels through the steering linkage.
- The valve spool is attached to the linkage, thereby moving it.

When the valve spool has moved far enough, it cuts off the oil flow through the cylinder. This stops the motion of the actuator.

It is therefore clear that mechanical feedback re-centers the valve (servo valve) in order to stop motion at the desired point which in turn is determined by the position of the steering wheel. Additional motion of the steering wheel is required to cause further motion of the output wheels.

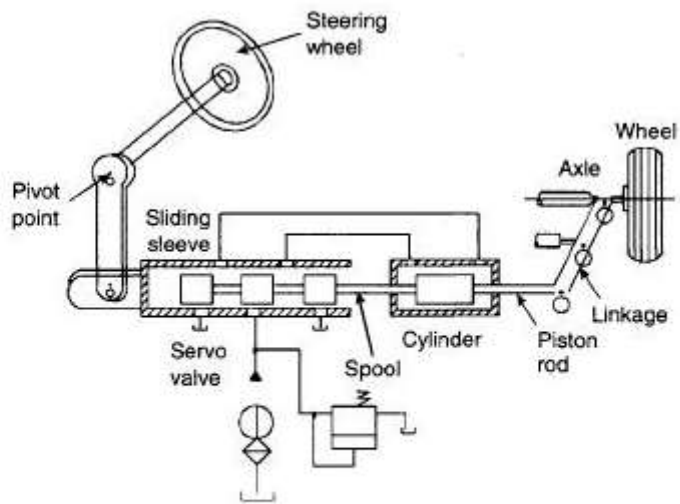

Figure 1

Video Content / Details of website for further learning (if any):

<https://cosmolearning.org/video-lectures/hydraulic-servomechanism-servo-proportional-control-valves/>

Important Books/Journals for further learning including the page nos.:

Hydraulic and Pneumatic Controls , R.Srinivasan,Vijay Nocile imprints private Limited pp: 85



MUTHAYAMMAL ENGINEERING COLLEGE

(An Autonomous Institution)

(Approved by AICTE, New Delhi, Accredited by NAAC & Affiliated to Anna University)

Rasipuram - 637 408, Namakkal Dist., Tamil Nadu



LECTURE HANDOUTS

L

MECH

II/IV

Course Name with Code : **Applied Hydraulics and Pneumatics**

Course Faculty : **Dr S.Suresh**

Unit : **V**

Topic of Lecture: Electro hydraulic servo systems and proportional valves

Introduction : (Maximum 5 sentences)

- An electrohydraulic servo valve is an electrically operated valve that controls how hydraulic fluid is sent to an actuator.
- Servo valves are often used to control powerful hydraulic cylinders with a very small electrical signal.
- Servo valves can provide precise control of position, velocity, pressure, and force with good post movement damping characteristics.
- A proportional valve provides a change in output pressure or flow in the same ratio as the change in the input, for example if the input doubles then the output will also double.
- Proportional valves can be interconnected with the output from one being used as the input to another.

Prerequisite knowledge for Complete understanding and learning of Topic:

(Max. Four important topics)

Direction Control valves, mechanical and electrical systems

Detailed content of the Lecture:

Diagram/ Description/Algorithm/Procedure for solving problems/ Derivation component with supporting content if any

- Electrohydraulic servo valves may consist of one or more stages. A single-stage servo valve uses a torque motor to directly position a spool valve.
- Single-stage servo valves suffer from limitations in flow capability and stability due to torque motor power requirements.
- Two-stage servo valves may use flapper, jet pipe, or deflector jet valves as hydraulic amplifier first stages to position a second-stage spool valve. This design results in significant increases in servo valve flow capability, stability, and force output.
- Similarly, three-stage servo valves may use an intermediate stage spool valve to position a larger third stage spool valve. Three-stage servo valves are limited to very

high power applications, where significant flows are required.

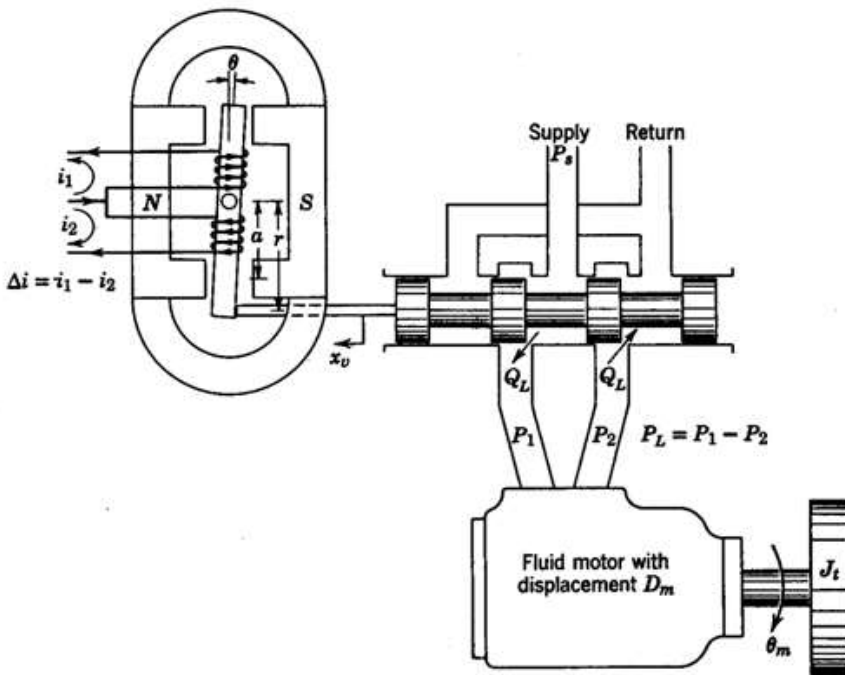
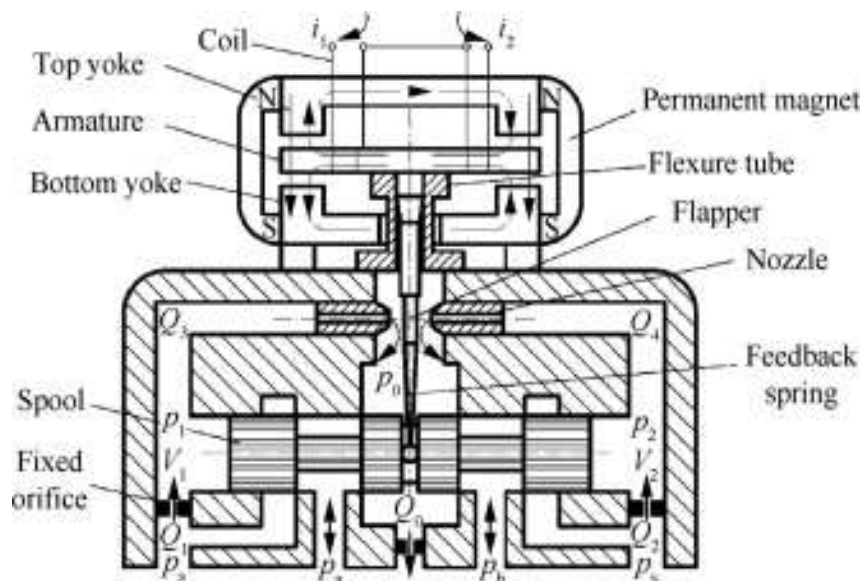

Figure 1. Single stage servo valve

- Furthermore, two-stage servo valves may be classified by the type of feedback used for the second stage; which may be spool position, load pressure, or load flow feedback.
- Most commonly, two-stage servo valves use position feedback; which may further be classified by direct feedback, force feedback, or spring centering.



- An electrohydraulic servovalve uses electrical current to move a "flapper", similar to a solenoid.
- The flapper controls the flow of hydraulic fluid to one side or the other of a spool valve. That moves the spool valve, allowing the supply pressure to feed an actuator cylinder, moving it one way or the other.

- However, that same movement also allows hydraulic pressure to return up to the flapper, providing a countering hydraulic force to the electrical force that moved it, called "negative feedback".
- Eventually these forces balance, and the flapper re-centers, closing the spool valve. The net result is that the actuator cylinder has moved a certain set distance, proportional to the strength of the input current.
- These valves are used to provide smooth, high-strength motion in a hydraulic system.
- This type of valve, for instance, can be used to move the control surfaces of a large airliner, without requiring high-pressure hydraulic lines or tensioned cables to link the hydraulic system to the yoke in the cockpit. Instead, the yoke (or sidestick) controls the current through electrical wires leading to the EHSV's.
- That link is much easier to maintain (and cheaper to build in the first place) than older systems on previous generations of aircraft.
- **Proportional valves** are well suited for circuits that need to vary either flow or pressure to reduce lunge and shock.
- The solenoids on these valves shift the spool more or less, According to the voltage applied to proportional solenoids, they can change the speed at which the spool shifts or the distance that it travels.
- Because the spool in a proportional valve does not shift all the way, all at once, the valves can control the acceleration and deceleration of an actuator.
- Usually, varying shifting time of the spool controls acceleration and deceleration. Varying voltage to the coil limits spool travel to control the maximum speed of an actuator.
- A computer, a PC, a programmable logic controller, or even a simple rheostat can produce the variable electric signal.

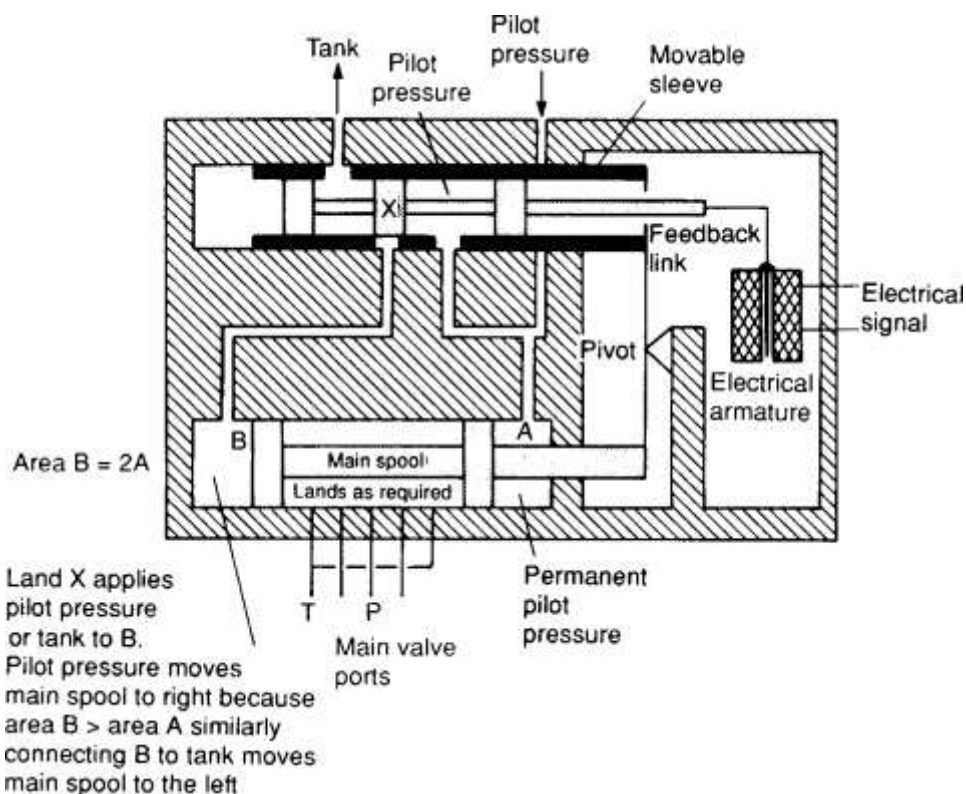

Simplified symbol for solenoid operated proportional valve with LVDT

- The figure above shows a very large hydraulic cylinder with a 3-stage proportional valve.
- The goal is to control the cylinder position.
- The first two valve stages have internal electronic controls, and all we need to know about them is that the first two stages will produce a velocity on the third stage that is roughly proportional to the Control Output signal received by the valve. The third stage has no electronic controls.

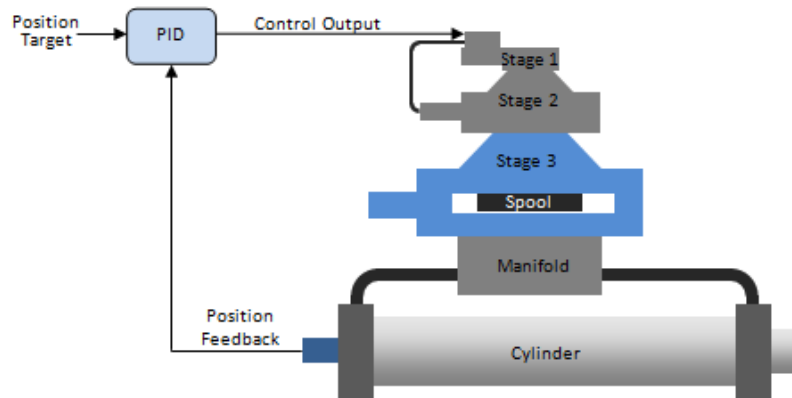

- Proportional relief valves are designed to open gradually as pressure increases. They open when the system reaches a set pressure, and close when the system falls below that same set pressure.
- Proportional pressure relief valves are continuously adjustable valves which limit the output pressure depending on the electrical current. These valves exist as leakage-free poppet valves and spool valves with defined leakage, in direct acting or pilot-operated design.

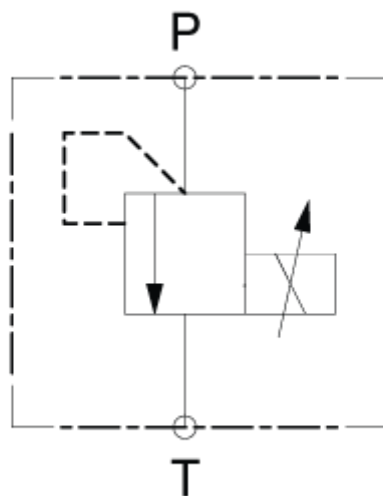

- The proportional pressure reducing/relieving valve size 06 is a pilot operated valve. It reduces a higher input pressure into a lower consumer pressure. The consumer pressure can be set proportionally to the solenoid current.

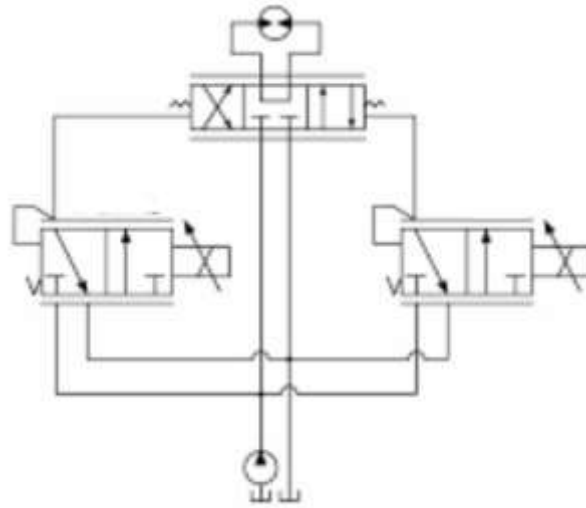

- Directional control valves (DCV) are one of the most fundamental parts in hydraulic system. They allow fluid flow into different paths from one or more sources. They usually consist of a spool inside a cylinder which is mechanically or electrically controlled.
- The movement of the spool restricts or permits the flow, thus it controls the fluid flow. But in a proportional valve it allow infinite positioning of spools, thus providing infinitely adjustable flow volumes. Either stroke-controlled or force-controlled solenoids are used to achieve the infinite positioning of spools.

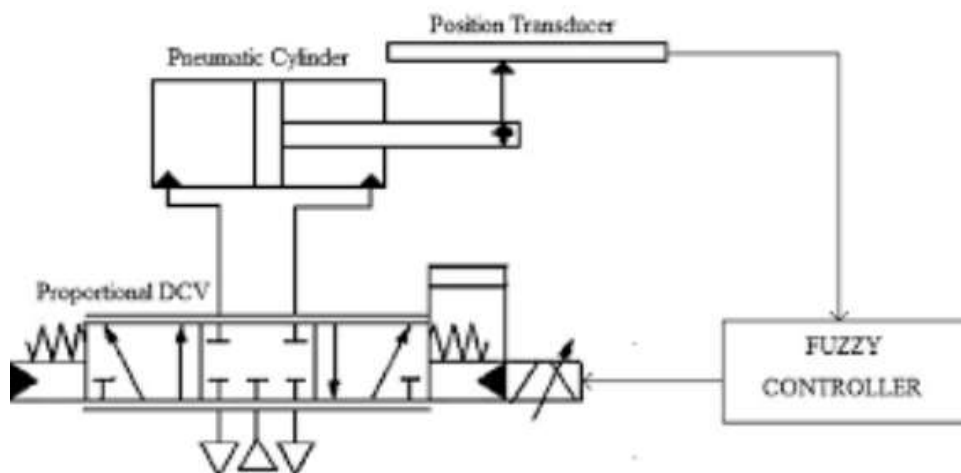

Video Content / Details of website for further learning (if any):

<https://www.coursera.org/lecture/fluid-power/servo-actuator-operation-bLbP2>

<https://www.whyps.com/Blog/hydraulic/advantages-of-proportional-directional-control-valves-when-compared-with-ordinary-bang-bang-directional-control-valves>

Important Books/Journals for further learning including the page nos.:

Hydraulic and Pneumatic Controls , R.Srinivasan,Vijay Nocile imprints private Limited pp: 89-93



MUTHAYAMMAL ENGINEERING COLLEGE

(An Autonomous Institution)

(Approved by AICTE, New Delhi, Accredited by NAAC & Affiliated to Anna University)

Rasipuram - 637 408, Namakkal Dist., Tamil Nadu



LECTURE HANDOUTS

L

MECH

II/IV

Course Name with Code : Applied Hydraulics and Pneumatics

Course Faculty : Dr S.Suresh

Unit : V

Topic of Lecture: Fluidics- Introduction

Introduction : (Maximum 5 sentences)

- The physical basis of fluidics is pneumatics and hydraulics, based on the theoretical foundation of fluid dynamics.
- The term fluidics is normally used when devices have no moving parts, so ordinary hydraulic components such as hydraulic cylinders and spool valves are not considered or referred to as fluidic devices.

**Prerequisite knowledge for Complete understanding and learning of Topic:
(Max. Four important topics)**

Direction Control valves, mechanical and electrical systems

Detailed content of the Lecture:

Diagram/ Description/Algorithm/Procedure for solving problems/ Derivation component with supporting content if any

- The Coanda Effect is in a simple description the tendency of a fluid to adhere to a curved surface because of the reduced pressure caused by the flow acceleration around the surface.
- This effect of attachment can be controlled either by injecting a thin jet of fluid tangential to the curved surface, or by acting with a control jet forcing the main jet to attach at the wall.

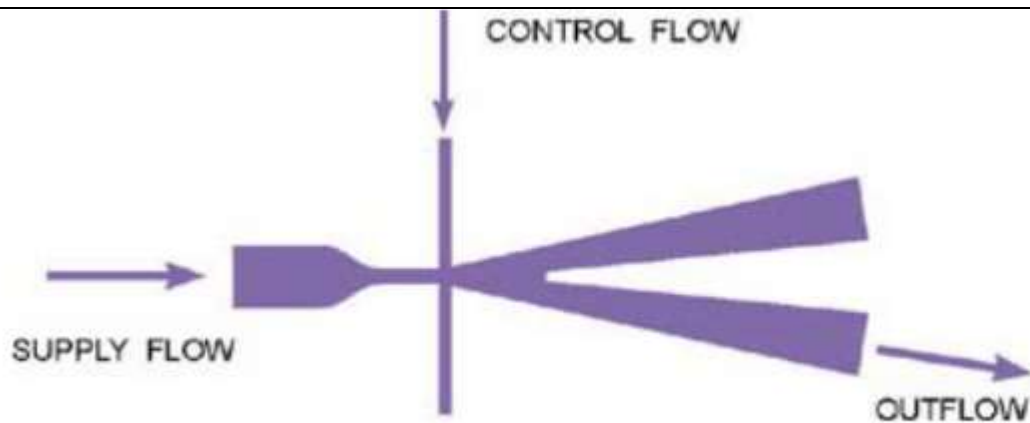

Fig. 1

- The function of these elements is based on the Coanda effect who maintains the attachment of the main jet from the supply flow on the wall, producing an output flow at the end of the device.
- By changing the control flow or pressure it is possible to bascule the main jet of the flow on the other output of the device and to obtain a stable function again.
- The construction of the element is simple, in general the element is done on a plate in which the aerodynamic configuration is engraved; a rigid plane plate fixed with screws is mounted on this plate and in its outer side there are some specific elements to assure the connections with the air supply and the fluidic inputs and outputs.
- The main jet injected causes a low pressure region called "attachment bubble" near the curved surface of the wall and the jet attaches to the curved surface and stays in a stable state. If an injection of fluid air is applied from the opposite part by a jet or a change in the pressure, the main jet swings from the right wall to the other symmetrical wall and attaches in this new position.
- After passing the main symmetric center line of the elements the main flow will attach to the opposite and the control jet can be stopped, the new position being stable

Bistable flip flap

The main task was in principal to develop a fluidic bistable element capable to respond at some specific conditions, namely:

- to use compressed industrial air at the normal industrial pressure (between 2-4 Bars) and quality,
- to have a simple design in order to be easy obtained with no special technologies,
- to have a specific method and algorithm for performances calculations in order to develop on this basis a class of execution fluidic elements.

Amplifiers

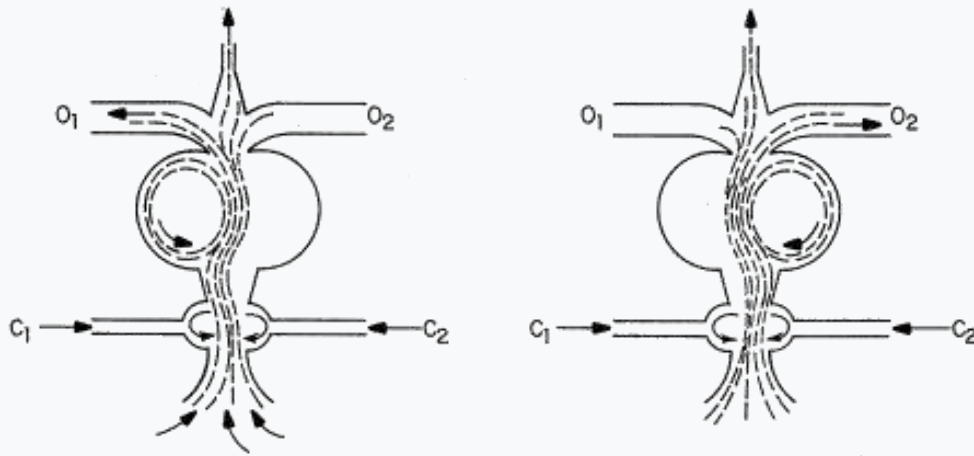

- In a fluidic amplifier, a fluid supply, which may be air, water, or hydraulic fluid, enters at the bottom.
- Pressure applied to the control ports C_1 or C_2 deflects the stream, so that it exits via either port O_1 or O_2 .
- The stream entering the control ports may be much weaker than the stream being deflected, so the device has gain.
- Given this basic device, flip flops and other fluidic logic elements can be constructed. Simple systems of digital logic can thus be built.

Fluidic amplifiers typically have bandwidths in the low kilohertz range, so systems built from them are quite slow compared to electronic devices.

Triodes: The fluidic triode is an amplification device that uses a fluid to convey the signal.

Video Content / Details of website for further learning (if any):

<https://hackaday.io/project/45555-fluidicpc>

<https://www.instructables.com/Circuits/Electronics>

Important Books/Journals for further learning including the page nos.:

Hydraulic and Pneumatic Controls , R.Srinivasan,Vijay Nocile imprints private Limited pp: 200-204



MUTHAYAMMAL ENGINEERING COLLEGE

(An Autonomous Institution)

(Approved by AICTE, New Delhi, Accredited by NAAC & Affiliated to Anna University)

Rasipuram - 637 408, Namakkal Dist., Tamil Nadu



LECTURE HANDOUTS

L

MECH

II/IV

Course Name with Code : 16MED10 APPLIED HYDARULICS AND PNUEMATICS

Course Faculty : Dr S.Suresh

Unit : V

Topic of Lecture: Simple Circuits

Introduction : (Maximum 5 sentences)

The application of flip flop in pneumatic circuits provides no wear and tear, no force, little space is needed, insensitive to temperature, vibration, shock, electric noise and radiation.

Prerequisite knowledge for Complete understanding and learning of Topic:
(Max. Four important topics)

Direction Control valves, mechanical and electrical systems

Detailed content of the Lecture:

Diagram/ Description/Algorithm/Procedure for solving problems/ Derivation component with supporting content if any

- The control of pneumatic cylinder using flip flop consist of push button switch, limit switch.
- The hall effect limit switch senses the position of the blank end of the piston.
- The figure show the application of flip flop in the pneumatic circuits.

Two-cylinder sequence

Actuating control	Step number	Function	Limit sensor
Start valve	1. Extend cylinder A	A+	LVA+ (limit valve)
LVA+	2. Retract cylinder A	A-	LVA- (limit valve)
LVA-	3. Extend cylinder B	B+	LVB+ (Hall-effect switch)
LVB+	4. Retract cylinder B	B-	LVB- (Hall-effect switch)
LVB-	5. Reset sequence	Reset	

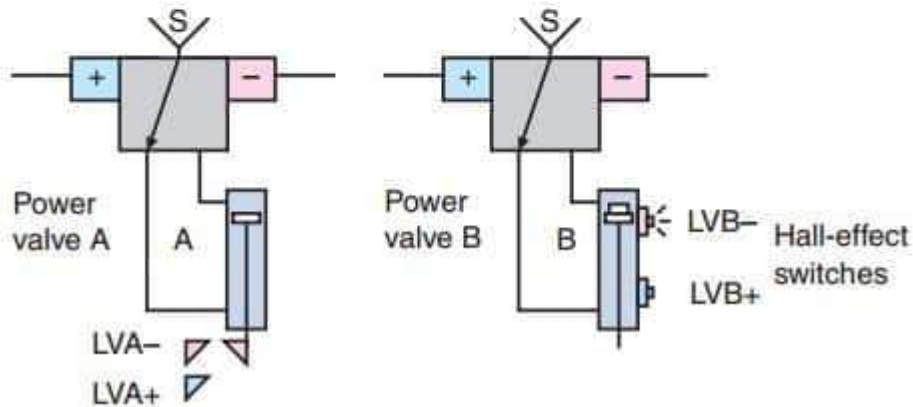

Video Content / Details of website for further learning (if any):

<https://nptel.ac.in/courses/112105047/>

Important Books/Journals for further learning including the page nos.:

Hydraulic and Pneumatic Controls , R.Srinivasan,Vijay Nocile imprints private Limited pp: 204-205



MUTHAYAMMAL ENGINEERING COLLEGE

(An Autonomous Institution)

(Approved by AICTE, New Delhi, Accredited by NAAC & Affiliated to Anna University)

Rasipuram - 637 408, Namakkal Dist., Tamil Nadu



LECTURE HANDOUTS

L

MECH

II/IV

Course Name with Code : 16MED10 APPLIED HYDARULICS AND PNUEMATICS

Course Faculty : Dr S.Suresh

Unit : V

Topic of Lecture: Introduction to electro hydraulics

Introduction : (Maximum 5 sentences)

- Typically, a electro-hydraulic system is one in which a feedback-controlled parameter regulates a hydraulic actuator, either linear or rotary.
- A parameter, e.g. displacement or load, is commanded and the actual parameter measured, and an error signal generated and applied to a servo-valve controller.
- The commanded waveform can be any wave form, static or dynamic, one shot or cyclic. It is very flexible and can applied commanded complex pre-programmed load or displacement parameters.
- Multiple independent channels can be applied and correlated. The range of loads can be applied is wide and the displacement precise.

Prerequisite knowledge for Complete understanding and learning of Topic:

(Max. Four important topics)

Mechanical and electrical systems

Detailed content of the Lecture:

Diagram/ Description/Algorithm/Procedure for solving problems/ Derivation component with supporting content if any

- Typically, a servo-hydraulic system consists of various components:
- A hydraulic power supply providing a motive source (e.g. electric motor), a hydraulic pump (often 3000 psi) an oil sump, particle filter, oil cooler and accumulator, relief valves.
- Manifolds, hard piping, flexible hoses and fitting,
- Hydraulic manual or servo-valves,
- Linear or rotary actuators,
- Load or displacement measuring equipment (optional for high performance and automated control)
- Feedback-control electronics, including PID controls (optional).
- A mounting frame or mobile device for load and reactions.

SOLENOID ACTUATED DC VALVES

- It is electro-mechanical devices that take electrical energy and produces a linear force by the use of magnetism. It is basically a winding of wire around a metal core.
- When the solenoid is energized, the air gap is closed quickly and a force is developed in the direction of the valve spool.

SOLENOID CONTROLLED, PILOT-OPERATED DCV

- Although a valve could be shifted directly by the force of a solenoid, large flow DCVs are most often shifted using fluid at system pressure.
- Larger flow valves demand larger shifting forces and it is no longer practical to use a solenoid there.

Video Content / Details of website for further learning (if any):

<https://nptel.ac.in/courses/112105047/>

Important Books/Journals for further learning including the page nos.:

Hydraulic and Pneumatic Controls , R.Srinivasan,Vijay Nocile imprints private Limited pp: 207-208



MUTHAYAMMAL ENGINEERING COLLEGE

(An Autonomous Institution)

(Approved by AICTE, New Delhi, Accredited by NAAC & Affiliated to Anna University)

Rasipuram - 637 408, Namakkal Dist., Tamil Nadu



LECTURE HANDOUTS

L

MECH

II/IV

Course Name with Code : Applied Hydraulics and Pneumatics

Course Faculty : Dr S.Suresh

Unit : V

Topic of Lecture: Pneumatic logic circuits-Ladder diagram

Introduction : (Maximum 5 sentences)

Two different types of logic circuits namely pneumatic logic cylinder sequencing circuit and control using flip flop.

**Prerequisite knowledge for Complete understanding and learning of Topic:
(Max. Four important topics)**

Direction Control valves, Mechanical and Electrical systems

Detailed content of the Lecture:

Diagram/ Description/Algorithm/Procedure for solving problems/ Derivation component with supporting content if any

- An AND element must receive two input signals simultaneously before it passes an output signal. This ensures that two upstream functions are complete before there is a command to a downstream function. In other words, inputs *A* and *B* must both be present before an output action occurs.
- When using more than two inputs, AND elements are connected in series. The first AND receives signals 1 and 2, and the output of this element interfaces with an input to the second AND.
- The other input of the second AND receives a third signal, making three inputs necessary before an output action can occur.

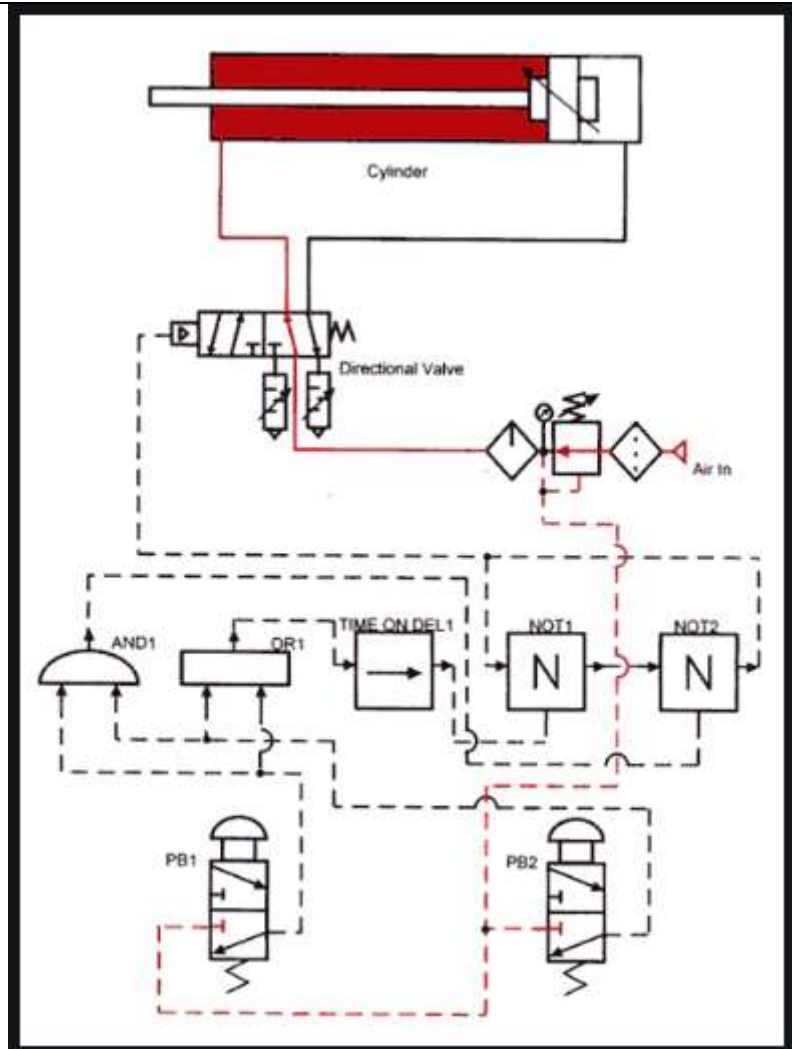

- A signal at either input port of an OR element produces an output signal.
- Another way of saying this is that either signal A or B will produce an output.
- A shuttle valve serves the same purpose as an OR element. Pilot signals from two different sources can pass through the OR to start the next function.
- An OR element differs from an in-line tee because an OR passes either input to the output but does not allow the inputs to pass to each other. OR elements can be stacked to accommodate more than two inputs. Use an extra OR for each input after the first two signals.
- A NOT logic element is a normally open 3-way valve. An input signal to the Supply port will pass through the valve until there is a pilot signal at port A.
- Pressurizing port A blocks supply and exhausts the output signal to atmosphere through port B. As long as there is pilot pressure on the A port, NOT elements will block a signal or supply.
- NOT elements always return to a normally open condition when the pilot signal is removed.
- A TIME-ON delay is a preset fixed timer without the sloping arrow. Most anti-tie down circuits use a fixed time delay. This forces the operator to actuate both palm buttons concurrently.

The sequential design using cascade method:

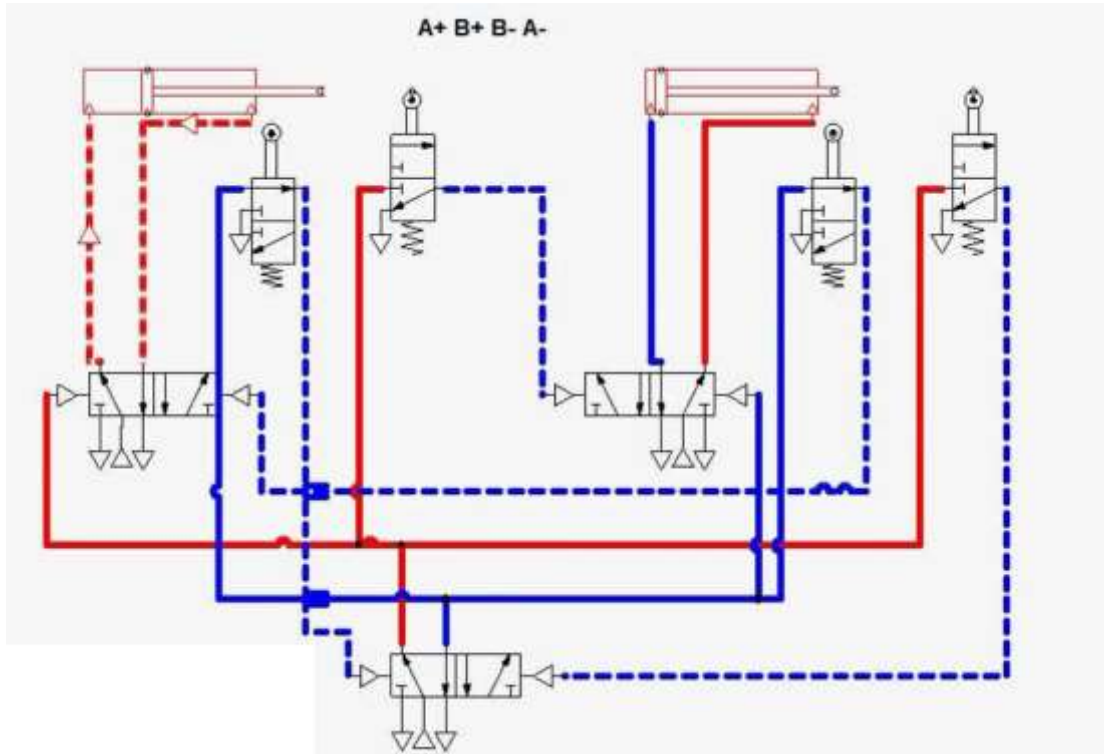

- **Ladder diagrams** are specialized schematics commonly used to document industrial control logic systems.
- They are called “ladder” diagrams because they resemble a ladder, with two vertical rails (supply power) and as many “rungs” (horizontal lines) as there are control circuits to represent.

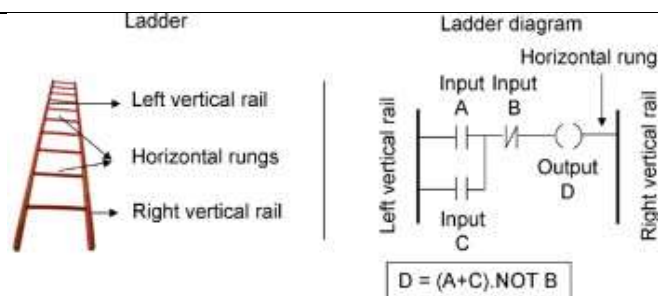

Video Content / Details of website for further learning (if any):

<https://hackaday.io/project/45555-fluidicpc>
<https://www.instructables.com/Circuits/Electronics>

Important Books/Journals for further learning including the page nos.:

Hydraulic and Pneumatic Controls , R.Srinivasan,Vijay Nocile imprints private Limited pp: 225-233



MUTHAYAMMAL ENGINEERING COLLEGE

(An Autonomous Institution)

(Approved by AICTE, New Delhi, Accredited by NAAC & Affiliated to Anna University)

Rasipuram - 637 408, Namakkal Dist., Tamil Nadu



LECTURE HANDOUTS

L

MECH

II/IV

Course Name with Code : Applied Hydraulics and Pneumatics

Course Faculty : Dr S.Suresh

Unit : V

Topic of Lecture: PLC applications

Introduction : (Maximum 5 sentences)

A programmable logic controller (PLC) or programmable controller is an industrial digital computer which has been ruggedized and adapted for the control of manufacturing processes, such as assembly lines, or robotic devices, or any activity that requires high reliability, ease of programming and process fault diagnosis.

**Prerequisite knowledge for Complete understanding and learning of Topic:
(Max. Four important topics)**

Mechanical and electrical systems

Detailed content of the Lecture:

Diagram/ Description/Algorithm/Procedure for solving problems/ Derivation component with supporting content if any

PLCs have a variety of applications and uses, including:

Process Automation Plants (e.g. mining, oil & gas)

Glass Industry

Paper Industry

Cement Manufacturing

In boilers - Thermal Power Plants

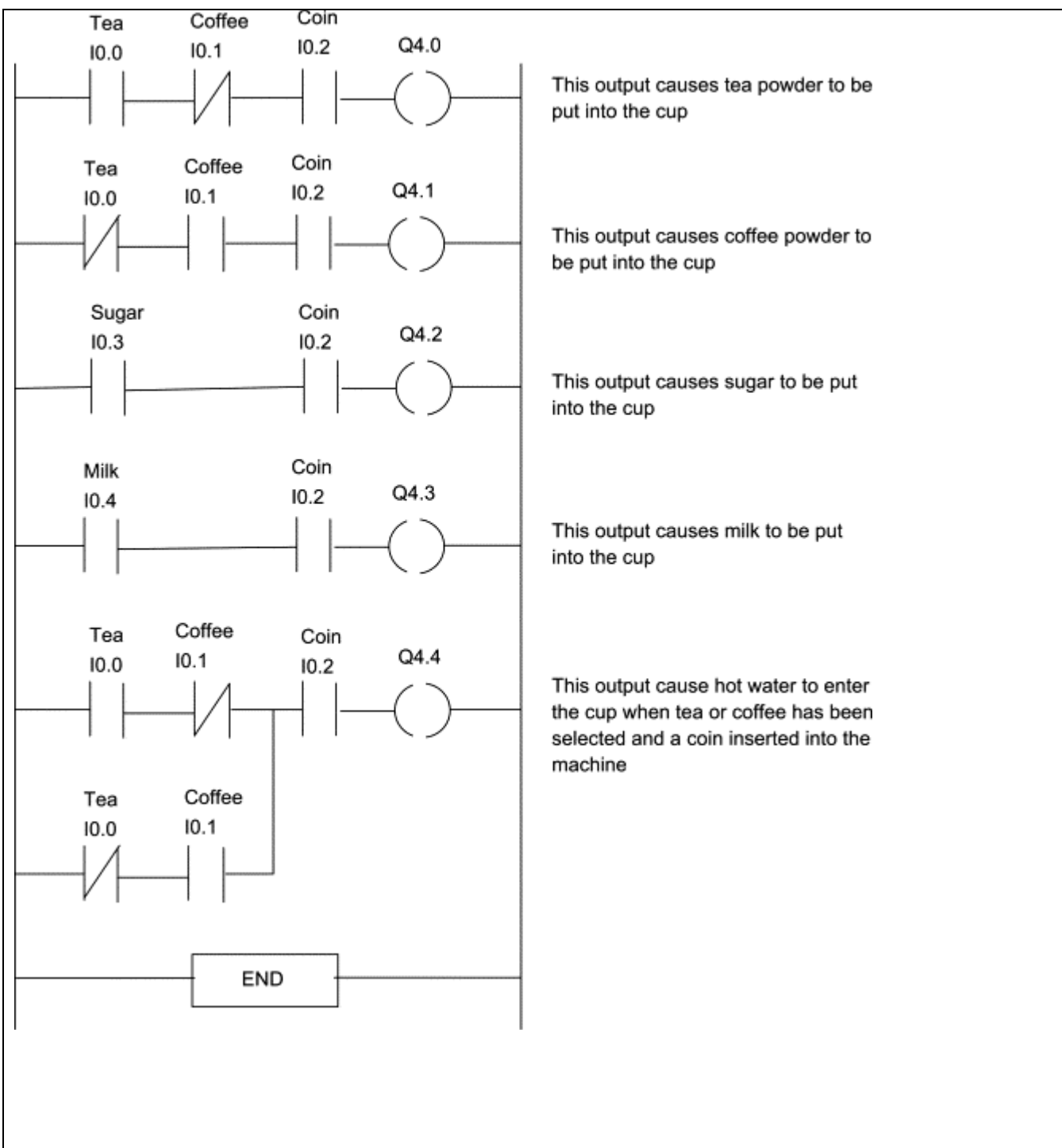

Video Content / Details of website for further learning (if any):

<https://www.plcademy.com › ladder-logic-tutorial>

Important Books/Journals for further learning including the page nos.:

Hydraulic and Pneumatic Controls , R.Srinivasan,Vijay Nocile imprints private Limited pp: 235-237



MUTHAYAMMAL ENGINEERING COLLEGE

(An Autonomous Institution)

(Approved by AICTE, New Delhi, Accredited by NAAC & Affiliated to Anna University)

Rasipuram - 637 408, Namakkal Dist., Tamil Nadu



LECTURE HANDOUTS

L

MECH

II/IV

Course Name with Code : Applied Hydraulics and Pneumatics

Course Faculty : Dr S.Suresh

Unit : V

Topic of Lecture: Fluid Power Circuits: Failure and Trouble Shooting

Introduction : (Maximum 5 sentences)

- Safety should be the first consideration when troubleshooting.
- Inspect the equipment and question the operator to help solve problems in FP systems.

**Prerequisite knowledge for Complete understanding and learning of Topic:
(Max. Four important topics)**

Mechanical and Electrical systems

Detailed content of the Lecture:

Diagram/ Description/Algorithm/Procedure for solving problems/ Derivation component with supporting content if any

- Many of the failures in a hydraulic system show similar symptoms: a gradual or sudden loss of high pressure, resulting in loss of power or loss of speed in the cylinders.
- The cylinder(s) may not move at all, or if they do they may move too slowly or may stall under light loads.
- Often the loss of power is accompanied by an increase in pump noise, especially as the pump tries to build up pressure against a load. Of course, any major component pump, relief valve, cylinder, 4-way valve, filter, etc., could be at fault. And in a highly sophisticated system there are other minor components which could be at fault, but these possibilities are too numerous to be covered in this brief discussion of troubleshooting.
- By following an organized step-by-step testing procedure in the order given here, the problem can usually be traced to a general area, then if necessary, each component in that area can be tested or can temporarily be replaced by another similar component.
- Step 1 - Pump Inlet Strainer.
- Step 2- Pump and Relief Valve.
- Step 3 - Pump or Relief Valve.
- Step 4 - Pump.
- Step 5 - Relief Valve.
- Step 6 - Cylinder.

- Step 7 - Directional (4-Way) Valve.
- **Hydraulic failures are a serious and ever-growing problem.**
- Fluid Contamination. Fluid contamination is often the primary cause of hydraulic failures, as it speeds up the rate of wear and tear on the pump. ...
- Over-Pressurization.
- Aeration.
- Pump Aeration.
- Implosion.
- Cavitation.
- Poor Hydraulic Fluid Viscosity.
- Excessive Heat.

Potential Cause	Solution
Improper installation of circuit Correct the installation.	See the Owner's Manual for more information.
Bad electrical connection	Replace any defective wires or blown 9-amp fuses. Clean corroded terminals, and check for corroded connections.
Low transmission oil level or air pressure	Fill the transmission to the manufacturer's specifications or check air system components.
Obstruction in circuit	Inspect and clean hoses and screens. Check for pinched or kinked hoses. See the Owner's Manual for how to check the circuit pressure.
Inoperative solenoid valve	Replace the solenoid valve.
Inoperative solenoid valve for system doesn't open fully and allow full pressure	12-volt systems require the solenoid valve with the green and white body. 24-volt systems require the solenoid valve with the black body. Replace as necessary.
Inoperative or damaged rocker switch	Replace the control box.
Excessive internal leakage in the PTO clutch pack (can be from damaged piston seal)	Replace the piston seal.
Allison World Transmission isn't programmed for PTO operation or operation under the desired conditions or speeds	Find the "ECU-CAL" assembly number from the transmission electronic control module and call a local Allison dealer.
Incorrect PTO for the type of actuator (air or hydraulic fluid)	Specify the correct Power Shift PTO for the type of actuation being used. Otherwise, the piston seal in the PTO will not function properly.

Video Content / Details of website for further learning (if any):

www.nptelvideos.in › 2012/11 › hydraulics,
www.infocobuild.com › mechanical-engineering › lecture-18

Important Books/Journals for further learning including the page nos.:

Hydraulic and Pneumatic Controls , R.Srinivasan,Vijay Nocile imprints private Limited pp: 235-237



MUTHAYAMMAL ENGINEERING COLLEGE

(An Autonomous Institution)

(Approved by AICTE, New Delhi, Accredited by NAAC & Affiliated to Anna University)

Rasipuram - 637 408, Namakkal Dist., Tamil Nadu



LECTURE HANDOUTS

L

MECH

II/IV

Course Name with Code : Applied Hydraulics and Pneumatics

Course Faculty : Dr S.Suresh

Unit : V

Topic of Lecture: Fluid Power Circuits: Failure and Trouble Shooting

Introduction : (Maximum 5 sentences)

- Every pneumatic circuit has a logical sequence of operation that can involve timing logic, pressure sensing, position sensing, and speed regulation. Troubleshooting is initiated when the circuit does not operate properly.
- Certain general diagnostic and testing steps can be applied to any troubleshooting problem, whether the problem occurred at startup of a new system or at a breakdown of an existing system.

Prerequisite knowledge for Complete understanding and learning of Topic: (Max. Four important topics)

Mechanical and electrical systems

Detailed content of the Lecture:

Diagram/ Description/Algorithm/Procedure for solving problems/ Derivation component with supporting content if any

- Safety should always be a prime concern of maintenance personnel. Compressed air is a volatile element in a pneumatic circuit. Air receiver tanks have exploded, causing severe injury to personnel and damage to property. It is imperative to relieve pressure in a receiver tank prior to making any repairs.
- Air is also highly compressible, which is another reason to be cautious in the approach to troubleshooting a pneumatic system. When working with overhead loads that are supported by cylinders, but not mechanically locked into position, block the load before servicing the system to prevent falling or drifting.
- Many pneumatic systems are controlled by electrical or electronic devices. Before attempting service or repair on these components, be sure the electrical power supply has been turned off.
- Pneumatic directional control valves that use electrical solenoids to operate the valve spool are often equipped with manual overrides (Fig. 1) that can be used during troubleshooting to operate the system.
- Pneumatic lockout valves (Fig. 2) are excellent safety devices that, when used properly on pneumatic systems, can prevent accidental operation. Ensuring a safe

condition should always be the first step in troubleshooting pneumatic systems.

12 Steps to troubleshooting pneumatic systems

- Troubleshooting a pneumatic system is neither art, nor science, nor should it be viewed as hit-or-miss; it is a procedural effort requiring 12 steps to accomplish.
- Think safety first.
- Ask the three Ws – What, When, and Where.
- Visually inspect the machine.
- Have a thorough understanding of the system. Use a schematic.
- Operate the machine.
- Recheck all services to the machine. Think safety.
- Isolate subsystems on the machine.
- Make a list of probable causes.
- Reach a conclusion about the problem.
- Test the conclusion.
- Repair or replace as necessary.
- Report the findings.

Video Content / Details of website for further learning (if any):

www.digimat.in › [nptel](#) › [courses](#) › [video](#)

www.womackmachine.com › [Engineering Toolbox](#) › [Data Sheets](#)

Important Books/Journals for further learning including the page nos.:

Hydraulic and Pneumatic Controls , R.Srinivasan,Vijay Nocile imprints private Limited pp: 235-237